



Med-Ép-Team Szolgáltató és  
Kereskedelmi Kft

## Kézi késtolózar kétirányú beépítéssel

Típus: HW-GG-Bld

Cím: H-7636 Pécs, Felső u. 56.

Mobil: +36 (30) 550 2976

Web: [www.medep.hu](http://www.medep.hu)

Email: [info@medep.hu](mailto:info@medep.hu)

### APPLICATION

General use: pulp production, water, water treatment, waste water, wine-producing...

### GENERAL CHARACTERISTICS

Non rising bi-directional tight knife gate valve.  
Function ON/OFF or regulation.  
Between flanges connection according to ISO PN10.  
Complete Sealed by nitrile elastomer seat in standard.  
Epoxy coated body RAL 6005, thickness 150 microns.  
Operating by handwheel.

### CONSTRUCTION

15	Nut	Zinc plated steel
14	Washer	Bronze
13	Handwheel	Cast iron, EN-GJL-250
12	Nut	Bronze
11	Stem	Stainless steel 303
10	Nut	Bronze
9	Greaser	Zinc plated steel
8	Nut support	Zinc plated steel
7	O-ring	Nitrile (NBR)
6	Packing	PTFE
5	Support	Epoxy coated steel
4	Seat	Nitrile (NBR)
3	Gland packing	Ductile iron
2	Gate	Stainless steel 304
1	Body	Cast iron, EN-GJL-250
Pos.	Description	Material

\* Pre-shaped parts up to DN300.

### DIMENSIONS

DN		A	B	C	H	F	V	ØPCD	ø	○	Depth	Weight (kg)
mm	inch											
50	2"	40	92	63	291	124	200	125	4xM16	0	8	7,5
65	2 1/2"	40	92	70	318	139	200	145	4xM16	0	8	8,8
80	3"	50	92	92	342	154	200	160	4xM16	4	10	9,4
100	4"	50	92	105	383	174	200	180	4xM16	4	10	11,5
125	5"	50	102	120	420	192	250	210	4xM16	4	10	15,4
150	6"	60	102	130	471	217	250	240	4xM20	4	12	19,8
200	8"	60	120	160	577	270	310	295	4xM20	4	12	34,8
250	10"	70	120	198	677	326	310	350	6xM20	6	15	47,0
300	12"	70	120	234	777	380	310	400	6xM20	6	15	68,0
350	14"	96	290	256	939	438	500	460	10xM20	6	19	129,0
400	16"	100	290	292	1037	493	500	515	10xM24	6	20	151,0

### WORKING CONDITIONS

Maximum working pressure :

DN50-200 : 10 bar  
DN250 : 8 bar  
DN300 : 6 bar  
DN350-400 : 4 bar

Maximum working temperature : -10°C / +90°C

### STANDARDS

Manufacture according to the requirements of the European directive 2014/68/UE «Equipments under pressure» : modulate H.  
On request : Product in accordance to european directive "Potentially explosive atmospheres" N° 94/9/EC :  
ATEX II 2 GD c and ATEX II 3 GD c.  
Test procedures are established according to standards EN 12266-1, DIN 3230, BS 5154 and ISO 5208.  
Connections between flanges according to standard EN 1092-2 and DIN 2501 ISO PN10.

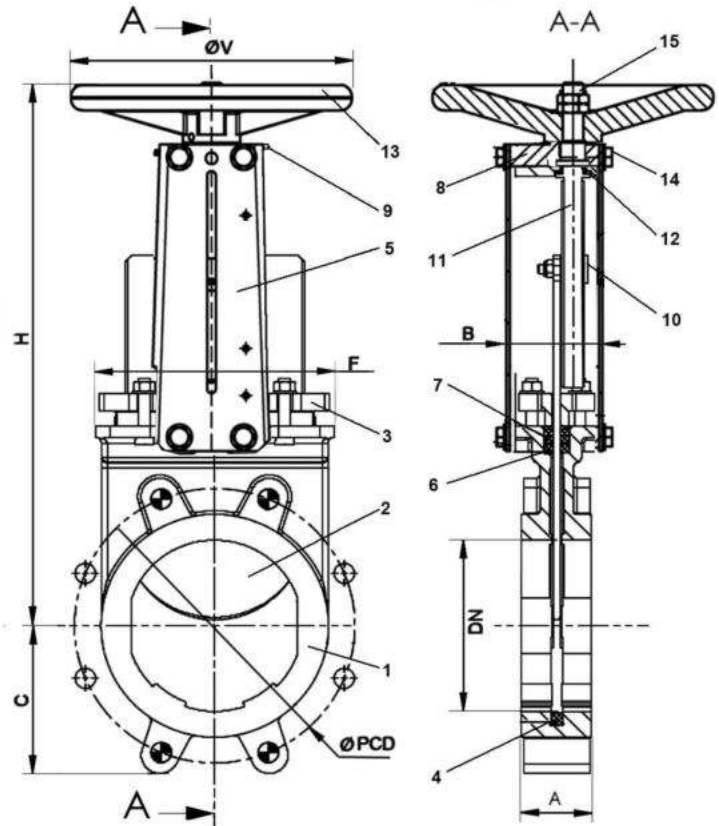
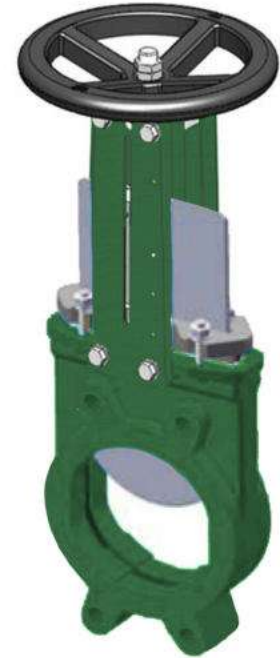

**Bi-directional tightness**