

APPLICATION

General use : This gate is particularly adapted in paper mill, in the exit of pulp, for the recovery of the old paper where the product is mixed with numerous impurities (ex: staples).

GENERAL CHARACTERISTICS

- Range : from DN 50 to DN 700.
- Bidirectional gate, with two seat gaskets.
- Longer body in two parts assembled by bolts.
- The gate is longer and its lower part rests out of the body, which requires a second system of gland packing.
- The gate contains a hole, which assures:
 - in opened position, a complete passage of the fluid without retention zone.
 - in closed position, the complete obturation.
- No retention zone: interesting in load or unloading of chemical device (dryer, reactor...).
- Valve tightness even in difficult conditions. No accumulation of product in the bottom of gate evacuation gorge.

CONSTRUCTION

19	1	Nut	Bronze	
18	1	Friction washer	Bronze	
17	1	Stop screw	Stainless steel	
16	1	Cap	Plastic	
15	1	Protection tube	Steel	
14	1	Handwheel	Cast iron	DIN : G25 ASTM : A48 class 40B BS : 1452 Grade 250
13	1	Greaser	Stainless steel	
12	1	Nut support	Zinc steel	
11	1	Position indicator	Stainless steel 304	
10	1	Stem	Stainless steel	
9*	2	Support plate	Steel + epoxy	
8	2	Packing gland	Aluminium	
7	1	Knife gate	X5CrNi 18-10	DIN : X5CrNi18 10 ASTM : A 182 AISI 304 BS : 1449-2 304 S15
6	2	Gasket	Nitril	
5	2	Support ring	Stainless steel 316	DIN : X5CrNiMo18 10 ASTM : A 182 AISI 316 BS : 970 316 S16
4	2	O-Ring	Nitril	
3	4	Packing	Tallowed cotton	
2	1	Second body	Cast iron EN-GJL-250	DIN : GG25 ASTM : A48 class 40B BS : 1452 Grade 250
1	1	Body	Cast iron EN-GJL-250	DIN : GG25 ASTM : A48 class 40B BS : 1452 Grade 250
Pos.	Qty.	Description	Material	

DIMENSIONS

DN	A	B	C		D	ØV	H	ØK	n x M	Weight (Kg)	
			Mini.	Max.							
50	2"	40	283	162	221	150	200	348	125	4 x M16	13
65	2 1/2"	40	308	190	264	168	200	388	145	4 x M16	15
80	3"	50	333	216	297	184	200	413	160	8 x M16	19
100	4"	50	378	245	354	205	200	488	180	8 x M16	23
125	5"	50	423	289	430	220	250	564	210	8 x M16	29
150	6"	60	474	330	530	240	250	635	240	8 x M20	38
200	8"	60	593	410	641	295	310	809	295	8 x M20	65
250	10"	70	685	486	772	355	310	946	350	12 x M20	100
300	12"	70	792	582	882	410	310	1118	400	12 x M20	122
350	14"	96	900	654	1043	NC	500	1282	460	16 x M20	163
400	16"	100	978	731	1168	NC	500	1441	515	16 x M24	235
450	18"	106	1105	809	1296	NC	500	1587	565	20 x M24	368
500	20"	110	1215	916	1454	NC	500	1809	620	20 x M24	471
600	24"	110	1418	1066	1706	NC	500	2060	725	20 x M27	532
700	28"	110	1640	1236	1981	NC	800	2372	840	24 x M27	936



Standard assembling



Strengthened assembling

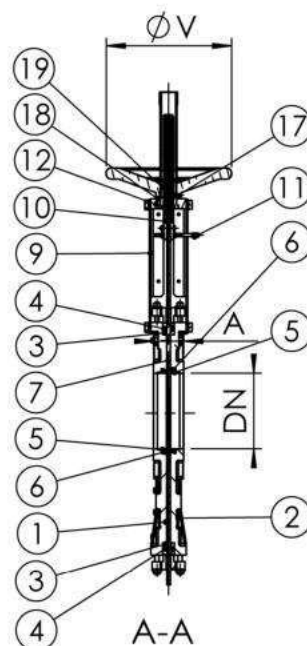
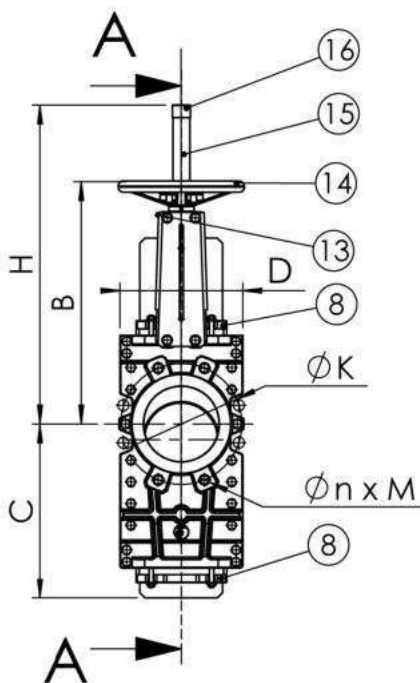

* Pre-sharped parts up to DN 300.

WORKING CONDITIONS

Maximum working pressure :

DN 50-250	: 10 bar
DN 300-400	: 6 bar
DN 450-600	: 3.5 bar
DN 700	: 2.5 bar

Maximum temperature : +80 °C

STANDARDS

Manufacture according to the requirements of the European directive 2014/68/UE «Equipments under pressure» : modulate H.

Test procedures are established according to standards EN 12266-1, DIN 3230, BS 5154 and ISO 5208.

Raised face in accordance to standard EN 1092-2.

Face to face according to standard TECOFI.

Wafer type ISO PN10 according to standard EN 1092-2.