



Med-Ép-Team Szolgáltató és
Kereskedelmi Kft

Kézi késtolózar kétirányú beépítéssel

Típus: HW-GG-Bld

Cím: H-7636 Pécs, Felső u. 56.

Mobil: +36 (30) 550 2976

Web: www.medep.hu

Email: info@medep.hu

APPLICATION

General use: pulp production, water, water treatment, waste water, wine-producing...

GENERAL CHARACTERISTICS

Non rising bi-directional tight knife gate valve.
Function ON/OFF or regulation.
Between flanges connection according to ISO PN10.
Complete Sealed by nitrile elastomer seat in standard.
Epoxy coated body RAL 6005, thickness 150 microns.
Operating by handwheel.

CONSTRUCTION

15	Nut	Zinc plated steel
14	Washer	Bronze
13	Handwheel	Cast iron, EN-GJL-250
12	Nut	Bronze
11	Stem	Stainless steel 303
10	Nut	Bronze
9	Greaser	Zinc plated steel
8	Nut support	Zinc plated steel
7	O-ring	Nitrile (NBR)
6	Packing	PTFE
5	Support	Epoxy coated steel
4	Seat	Nitrile (NBR)
3	Gland packing	Ductile iron
2	Gate	Stainless steel 304
1	Body	Cast iron, EN-GJL-250
Pos.	Description	Material

* Pre-shaped parts up to DN300.

DIMENSIONS

DN		A	B	C	H	F	V	ØPCD	ø	○	Depth	Weight (kg)
mm	inch											
50	2"	40	92	63	291	124	200	125	4xM16	0	8	7,5
65	2 1/2"	40	92	70	318	139	200	145	4xM16	0	8	8,8
80	3"	50	92	92	342	154	200	160	4xM16	4	10	9,4
100	4"	50	92	105	383	174	200	180	4xM16	4	10	11,5
125	5"	50	102	120	420	192	250	210	4xM16	4	10	15,4
150	6"	60	102	130	471	217	250	240	4xM20	4	12	19,8
200	8"	60	120	160	577	270	310	295	4xM20	4	12	34,8
250	10"	70	120	198	677	326	310	350	6xM20	6	15	47,0
300	12"	70	120	234	777	380	310	400	6xM20	6	15	68,0
350	14"	96	290	256	939	438	500	460	10xM20	6	19	129,0
400	16"	100	290	292	1037	493	500	515	10xM24	6	20	151,0

WORKING CONDITIONS

Maximum working pressure :

DN50-200 : 10 bar
DN250 : 8 bar
DN300 : 6 bar
DN350-400 : 4 bar

Maximum working temperature : -10°C / +90°C

STANDARDS

Manufacture according to the requirements of the European directive 2014/68/UE «Equipments under pressure» : modulate H.
On request : Product in accordance to european directive "Potentially explosive atmospheres" N° 94/9/EC :
ATEX II 2 GD c and ATEX II 3 GD c.
Test procedures are established according to standards EN 12266-1, DIN 3230, BS 5154 and ISO 5208.
Connections between flanges according to standard EN 1092-2 and DIN 2501 ISO PN10.

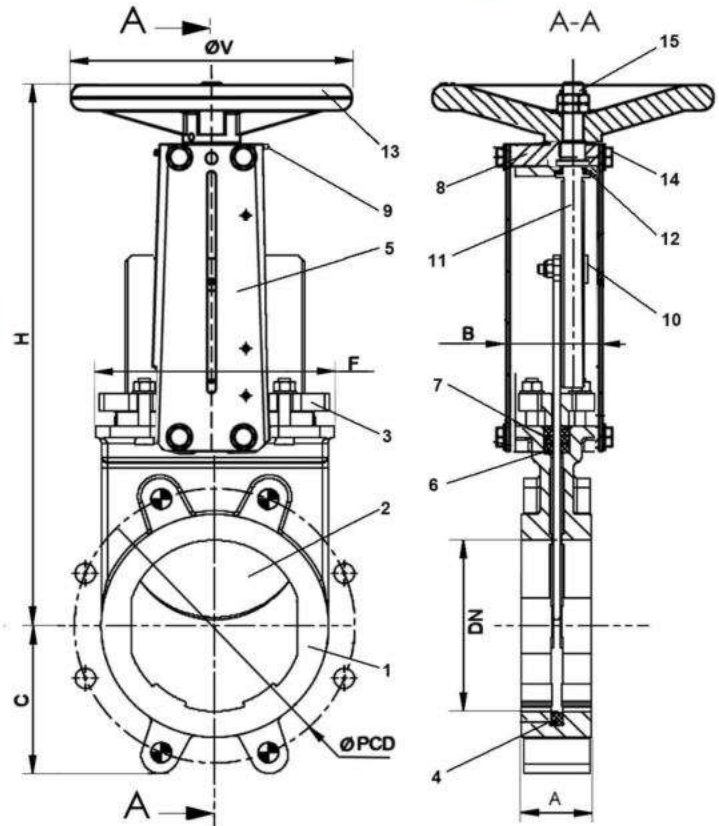
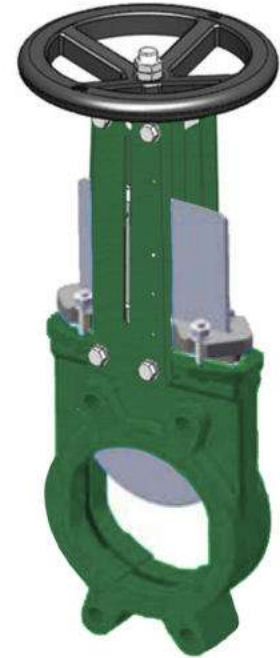

Bi-directional tightness