

Clear

Automatic labellers for pressure-sensitive labels



Labeller 20 mt/minute

Clear is a compact labeller with speeds of up to 20 metres/minute designed for low to medium speed packaging lines or end-of-line applications. It has the technology and structure of an industrial labeller: Clear is solid, accurate and reliable.

Etipack reserves the right to modify according to the technical evolution, without notice. All the rights of intellectual and technological ownership are reserved

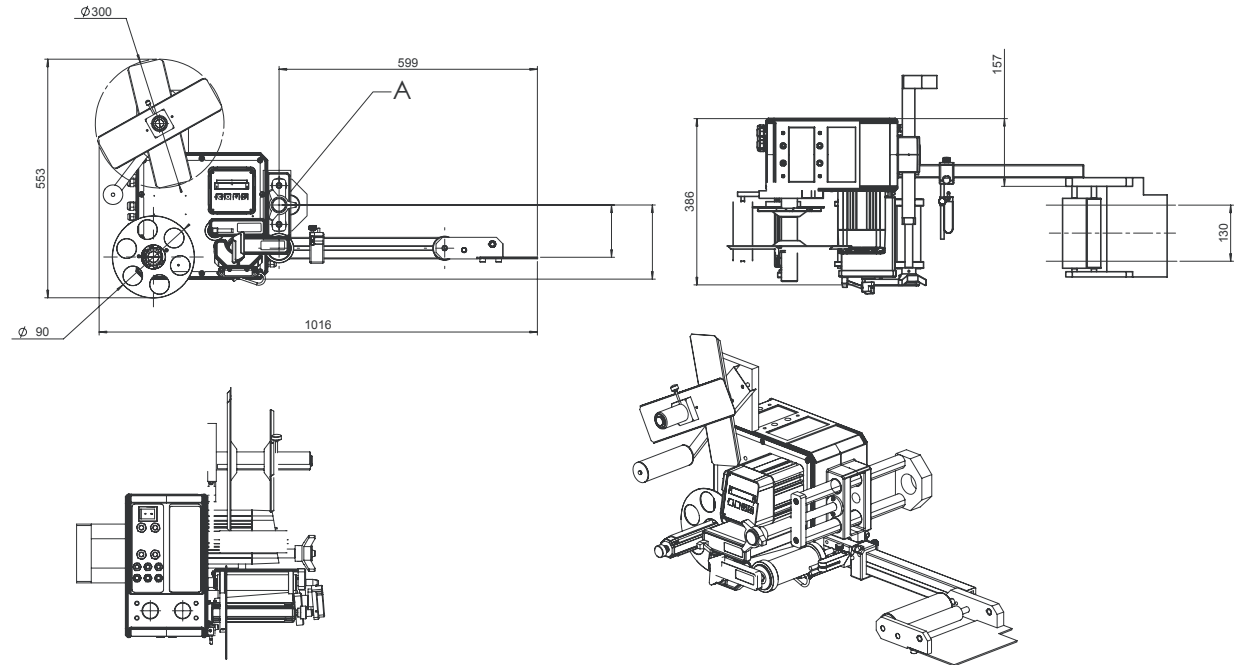

TECHNICAL SPECIFICATIONS

	Clear 1.3	Clear 2.5
Dispensing speed	20 mt/min	10 mt/min
Dispensing width	8-128 mm	8-248 mm
Outside reel diameter	280 mm	280 mm
Inside reel diameter	40-75 mm	40-75 mm
Motor	stepper motor	stepper motor
Compressed air	6 bar with print units and applicators	6 bar with print units and applicators
Machine size length - width - h	1016 x 386 x 553 mm	1015 x 526 x 553 mm
Power supply	115/230 V, 50-60 Hz	115/230 V, 50-60 Hz
Electrical input	100 W	100 W
Electrical protection	IP 55	IP 55
Noise level	70 dB	70 dB
Pneumatic version	-	-