

ES 6000

Fully automatic
labelling



ES 1000
ES 2000
ES 3000
ES 4000
ES 5000
ES 6000
ES 7000
ES 8000
ES 9000



ES 6000

Weigh-labelling for products up to 30 kg or 80 kg

- Fully automatic machine with a wide range of labelling possibilities
- Labelling performance up to 40 packs per minute
- Interactive weigh-labelling by using the management system ESMS

ES 6002 / 30 kg
Labelling from all sides

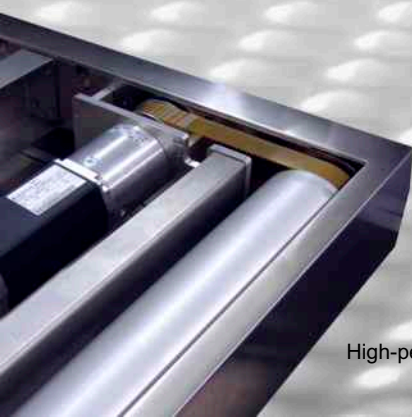

High-performance motor

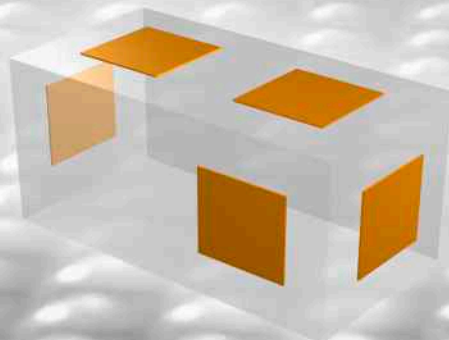

The very flexible positioning of the printer enables labelling of boxes on the top, on the side, on the front or on the back.



ES 6100



The ES 6000 series can be integrated into existing production lines, whether in right or left running direction.

The compact ES 6100 with one conveyor only can label packages of up to 30 kg on the side, on the top or on the backside.

The free movable printer module and the turnable print system allow many different label positions.

Height adjustment by use of the gas-filled spring supported printer bridge



ES 6900

ES 6900 Pallet Labeller

The ES 6900 can print and apply SSCC labels on two sides without turning the pallet.

The labels printed according to GS1 standards can be exactly identified by all barcode control systems.

The machine is made from stainless steel and can easily be integrated in an existing conveyor system.

The printer ESD 404 can be equipped with a big label roll and works independently with or without PC control.

Model	ES 6000	ES 6100
Terminal	ESC with touch screen	
User interface	ESMS	
Weighing range	30 / 80 kg*	
Performance pack./min.**	up to 40	up to 15
Package size in mm	L x W x H	
Maximum	550 x 500 x 480	500 x 500 x 480
with add. conveyor	550 x 400 x 480	500 x 400 x 480
with option for long packages	L 750 mm	L 600 mm
Conveyor speed	variable	
Product detection	light barrier	
12 Dot/mm/300 dpi	yes	
Label passage	110 mm	
Maximum printing speed	250 mm/s	
Print width	104 mm	
Label minimum W x L	37 x 37 mm	
Label maximum W x L	106 x 170 mm***	
Label reel core / outside diameter	76 mm / 210 mm	
RS 232	yes	
USB	yes	
Ethernet	yes	
PS/2 connection/parallel	yes	
Mains voltage	190 V to 260 V / 50 – 60 Hz	
Protection class	IPX4	
Operating temperature	-10 °C to +40 °C	

* with safety device

** depending on pack and label size

*** for the use of big labels we recommend tests in our premises.

Model	ES 6900
Printer	ESPERA ESD 404
12 Dot/mm / 300 dpi	yes
Label Dimensions W x L	150 x 200 mm
Label Reel Core ø	38 – 76 mm
Label Reel Outside ø	203 mm
Performance only front label	~ 7 labels/min
Performance front and lateral label	~ 5 labels/min
Print Direction	vertical
Connection to Scale	yes
Labelling Technology	Vacuum / Air Blow
Compressed Air	6 bar
Labelling Direction	0° and 90°
Labelling Distance	650 mm
Weight	95 kg
Power Consumption	max. 810 W
Mains Voltage	180 V - 255 V / 50 – 60 Hz
Operation Temperature	+5 °C to +40 °C
Design	Stainless steel
Option	Product photo cell

The photographs show specific machine configurations. Subject to technical modifications.

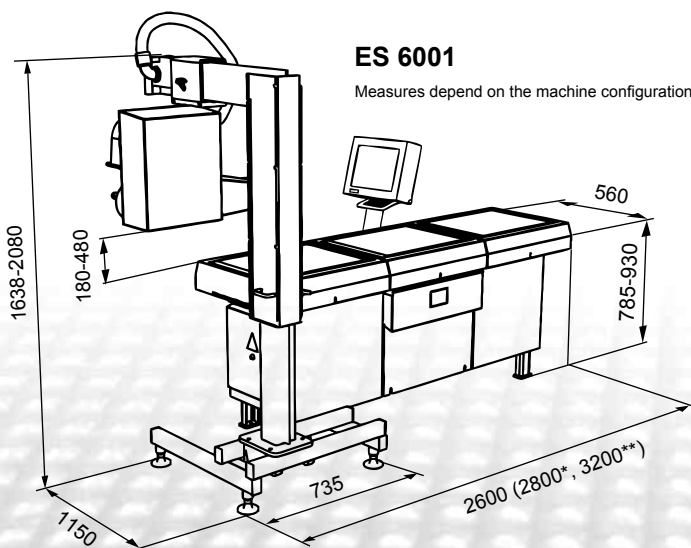

* with scale conveyor extension
** with optional infeed conveyor

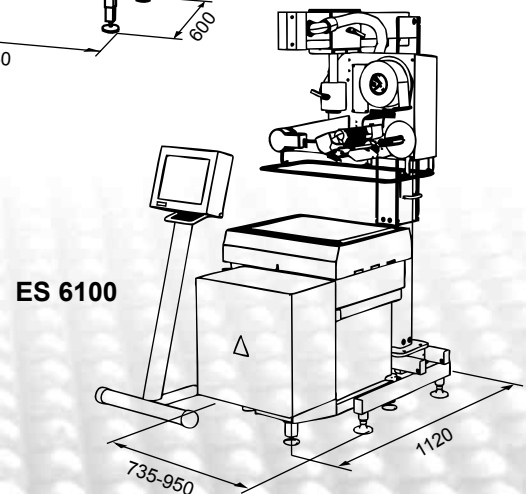
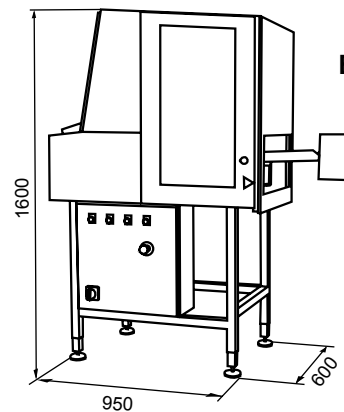

Altrapack Hungary Kft.

H 1119 Budapest, Keveháza utca 1-3.

Tel.: 1 783-1884 Fax.: 1 783-1885

altrapack@altrapack.hu

www.altrapack.hu