

ES 6900

Pallet Labeller



ES 1000

ES 2000

ES 3000

ES 4000

ES 5000

ES 6000

ES 7000

ES 8000

ES 9000



Model	ES 6900
Printer	ESPERA ESD 404
12 Dot/mm / 300 dpi	yes
Label Dimensions W x L	150 x 200 mm
Label Reel Core ø	38 – 76 mm
Label Reel Outside ø	203 mm
Performance only front label	~ 7 labels/min
Performance front and lateral label	~ 5 labels/min
Print Direction	vertical
Connection to Scale	yes
Labelling Technology	Vacuum / Air Blow
Compressed Air	6 bar
Labelling Direction	0° and 90°
Labelling Distance	650 mm
Weight	95 kg
Power Consumption	max. 810 W
Mains Voltage	180 V - 255 V / 50 – 60 Hz
Operation Temperature	+5 °C to +40 °C
Design	Stainless steel
Option	Product photo cell

The ES 6900 can print and apply SSCC labels on two sides without turning the pallet.

The labels printed according to GS1 standards can be exactly identified by all barcode control systems.

The machine is made from stainless steel and can easily be integrated in an existing conveyor system.

The printer ESD 404 can be equipped with a big label roll and works independently with or without PC control.



Lateral labelling without turning the pallet.



Big labels rolls with a diameter of 203 mm.



The labelling arm can be turned by 90°.

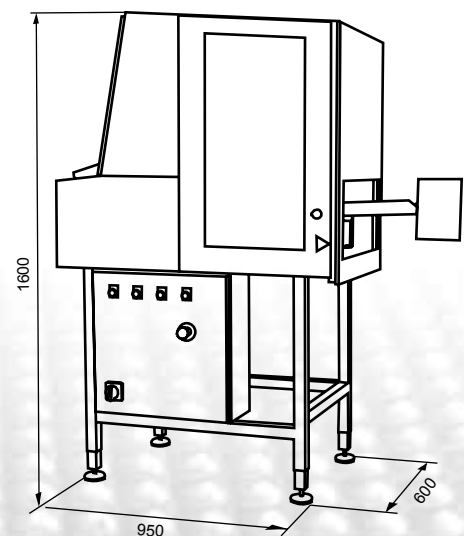

Altrapack Hungary Kft.

H 1119 Budapest, Keveháza utca 1-3.

Tel.: 1 783-1884 Fax.: 1 783-1885

altrapack@altrapack.hu

www.altrapack.hu