



**HD 2903T..., HD 29V3T..., HD 2937T..., HD 29V37T...  
HD 29371T..., HD 29V371T...  
TEMPERATURE, RELATIVE HUMIDITY AND AIR SPEED  
TRANSMITTERS**

The family of transmitters series HD29 ... are employed in the control of air speed in the air conditioning and ventilation (HVAC / BEMS) in the pharmaceutical, museum, clean rooms, ventilation ducts, industrial sectors and households, crowded places, cafeterias, auditoriums, gymnasiums or on farms with large numbers of animals. The sensors in combination with an accurate electronics guarantee precise and reliable measurements in the time.

The sensor for the air speed is thin film, the probe sheath is AISI304, the filter relative humidity of 20µ wire mesh, materials that allow the use in hostile areas. There are two possible installations: in the TO version, the horizontal probe is joined to the electronics enclosure while in the TC version the probe is con-



PG16

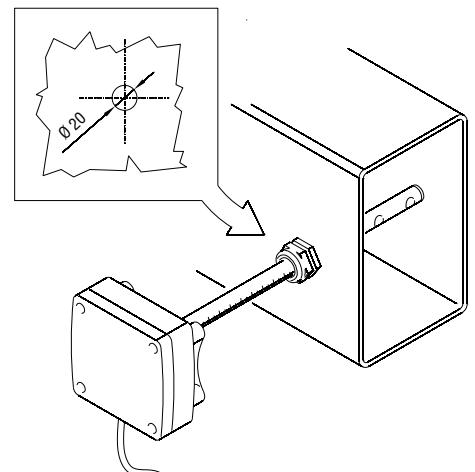

nected to the electronics through a cable.

In the TO version, the duct probe is fixed to the electronics enclosure and it is available in three different lengths. To fix the probe to the duct, you can use, for example, the HD9008.31 flange, a 3/8" universal biconical connection or a PG16 metal cable gland (Ø10...14mm).

In the TC version, the probe together with the sensors is equipped with a cable which can be 2, 5 or 10 meters long. The probes are available in three different lengths.

Common technical specifications		Notes
Air speed Measuring range	0.05...1m/s 0.1...2m/s 0.20...10m/s 0.20...20m/s	The measuring range can be selected by dip-switch.
Air speed Accuracy range 0...1m/s range 0...2m/s range 0...10m/s range 0...20m/s	±(0.06m/s+2% of measurement) ±(0.06m/s+2% of measurement) ±(0.4m/s+3% of measurement) ±(0.4m/s+3% of measurement)	at 50%RH and 1013hPa
Temperature Measuring range	-10...+60°C	HD2937, HD29V37, HD29371 and HD29V371 models
Temperature Accuracy	±0.3°C	
Relative Humidity Measuring range	5...98%RH	HD29371 and HD29V371 models
Relative Humidity Accuracy	±2.5% (5...90%RH), ±3.5% remaining range	
Relative Humidity Output Range	0...100%RH	
Output (according to the models)	4...20mA 0...10Vdc	R <sub>L</sub> < 500Ω R <sub>L</sub> > 10kΩ
Power supply	16...40Vdc or 12...24Vac±10%	
Response time (selected by jumper)	0.2s 2.0s	Fast Slow
Operating temperature electronics probe	0...+60°C -10...+80°C	
Compensation temperature	0...+80°C	
Storage temperature	-10...+70°C	
Electronics protection class	IP67	
Sensor working conditions	Clean air, RH<80%	
Case dimensions	80x84x44	Without probe

**Model description**

Model	Output		Measured parameters		
	4...20mA	0...10Vdc	Air speed	Temperature	Relative Humidity
HD2903T...	✓		✓		
HD29V3T...		✓	✓		
HD2937T...	✓		✓	✓	
HD29V37T...		✓	✓	✓	
HD29371T...	✓		✓	✓	✓
HD29V371T...		✓	✓	✓	✓

**Installation notes**

- The window of the sensor (or of the sensors) must be oriented in the direction of flow. To facilitate the proper positioning of the probe, eg. inside of a pipe, a graduated scale, engraved along the stem, indicates the depth of introduction of the window speed sensor in the channel. To properly orient the sensor to the flow, once introduced into the channel, the air speed window and line on the base of the scale are on the same axis.

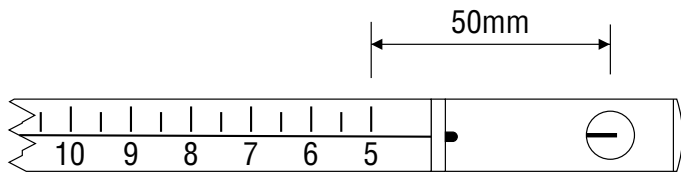

- To fix the probe inside a ventilation duct, a pipe, etc. you can use, for example, HD9008.31 flange, a PG16 metal cable gland (Ø10...14mm) or a 3/8" universal biconical connector.

	<p><b>HD9008.31 Flange</b></p>
	<p><b>PG16 metal cable gland</b>  D = 10...14mm  L = 6.5mm  H = 23mm  A = PG16</p>
	<p><b>Universal biconical connector</b>  L = 35mm  D = 14mm  A = 3/8"</p>

- The transmitters are factory calibrated and no further adjustments are required.
- To select the air speed **output range** by using the dual dip-switch on the board, please see the chart below:

Output range	0...1m/s	0...2m/s	0...10m/s	0...20m/s
Dip-switch position				

- Dip-switch should always be at the end of its final limit in both directions.

- The jumper on the board selects an **integrated response time in 0.2s in the FAST position and in 2s in the SLOW position. Please set the integration time at SLOW in case of turbulence, otherwise please select the FAST position.**

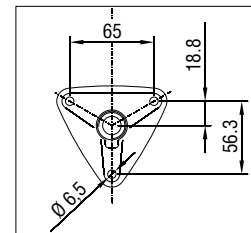
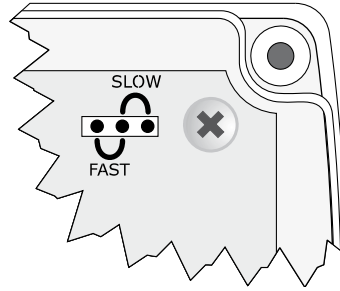

HD9008.31 Flange

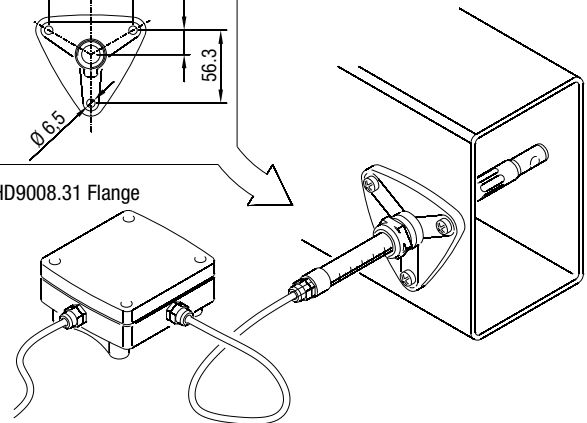

Air speed



## Electrical connections

### Power supply

Power the instrument at the voltage shown in the electrical specifications: power supply terminals are marked as +Vdc and GND.

### Analogue output

According to the model, the output signal comes from:

- VEL and GND terminals for air speed transmitters,
- VEL and GND, Temp and GND terminals for temperature / air speed transmitters,
- VEL and GND, Temp and GND, %RH and GND terminals for temperature / relative humidity / air speed transmitters.

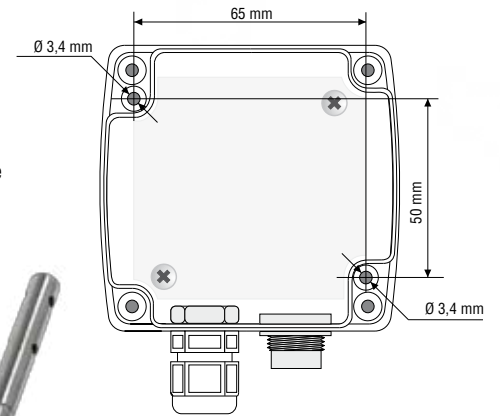
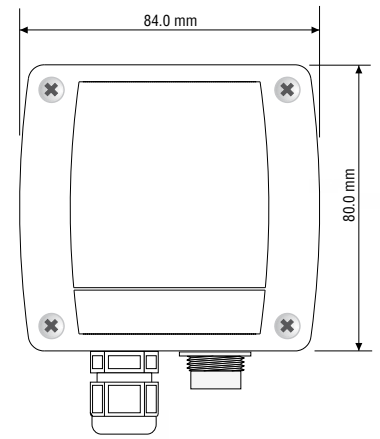
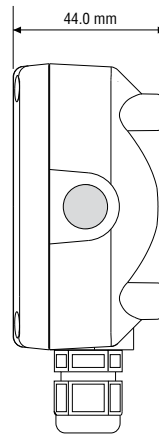
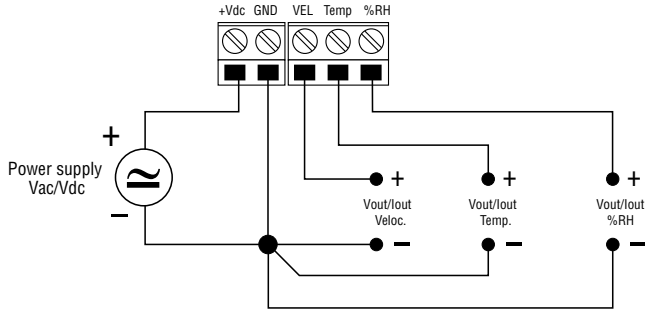

Template



### HD2903T... and HD29V3T... ORDERING CODES

**HD2903T...**: Active transmitter for measuring air speed in ducts, 4...20mA output. AISI 304 steel probe, diameter 12mm, compact unit HD2903TO... version with probe joined to the electronics enclosure, HD2903TC... version with probe connected to the electronics through a cable. Air speed range 0.05...1m/s - 0.1...2m/s - 0.20...10m/s - 0.20...20m/s selected by jumper. Power supply 16...40Vdc or 12...24Vac. Air probe operating temperature -10+80°C.

**HD29V3T...**: Active transmitter for measuring air speed in ducts, 0...10Vdc output. AISI 304 steel probe, diameter 12mm, compact unit HD29V3TO... version with probe joined to the electronics enclosure, HD29V3TC... version with probe connected to the electronics through a cable. Air speed range 0.05...1m/s - 0.1...2m/s - 0.20...10m/s - 0.20...20m/s selected by jumper. Power supply 16...40Vdc or 12...24Vac. Air probe operating temperature -10+80°C.

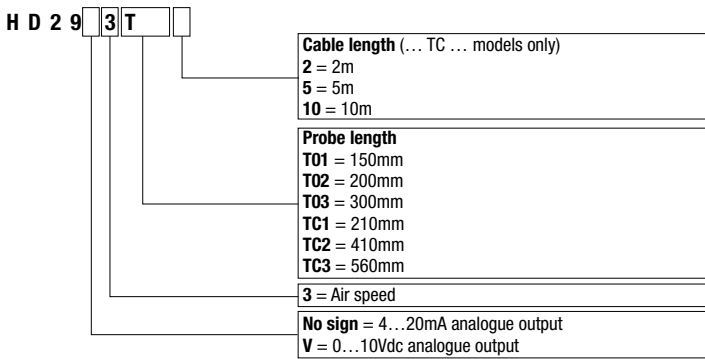

### HD2937T... and HD29V37T... ORDERING CODES

**HD2937T...**: Active transmitter for measuring air speed and temperature in ducts, 4...20mA outputs. AISI 304 steel probe, diameter 12mm, compact unit HD2937TO...version with probe joined to the electronics enclosure, HD2937TC...version with probe connected to the electronics through a cable. Air speed range 0.05...1m/s - 0.1...2m/s - 0.20...10m/s - 0.20...20m/s selected by jumper, fixed temperature range -10...+60°C. Power supply 16...40Vdc or 12...24Vac. Air probe operating temperature -10+80°C.

**HD29V37T...**: Active transmitter for measuring air speed and temperature in ducts, 0...10Vdc outputs. AISI 304 steel probe, diameter 12mm, compact unit HD29V37TO...version with probe joined to the electronics enclosure, HD29V37TC... version with probe connected to the electronics through a cable. Air speed range 0.05...1m/s - 0.1...2m/s - 0.20...10m/s - 0.20...20m/s selected by jumper, fixed temperature range -10...+60°C. Power supply 16...40Vdc or 12...24Vac. Air probe operating temperature -10+80°C.

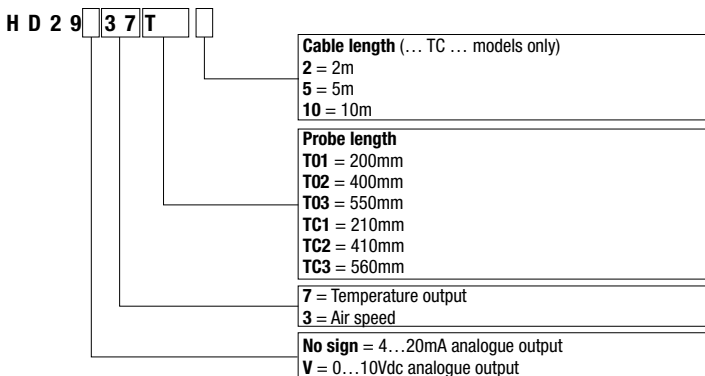

### HD29371T... and HD29V371T... ORDERING CODES

**HD29371T...**: Active transmitter for measuring air speed, temperature and relative humidity in ducts, 4...20mA outputs. AISI 304 steel probe, diameter 14mm, compact unit HD29371TO version... with probe joined to the electronics enclosure, HD29371TC... version with probe connected to the electronics through a cable. Air speed range 0.05...1m/s - 0.1...2m/s - 0.20...10m/s - 0.20...20m/s selected by jumper, fixed temperature range -10...+60°C, relative humidity range 0...100%RH. Power supply 16...40Vdc or 12...24Vac. Air probe operating temperature -10+80°C.

**HD29V371T...**: Active transmitter for measuring air speed, temperature and relative humidity in ducts, 0...10Vdc outputs. AISI 304 steel probe, diameter 14mm, compact unit HD29V371TO...version with probe joined to the electronics enclosure, HD29V371TC... version with probe connected to the electronics through a cable. Air speed range 0.05...1m/s - 0.1...2m/s - 0.20...10m/s - 0.20...20m/s selected by jumper, fixed temperature range -10...+60°C, relative humidity range 0...100%RH. Power supply 16...40Vdc or 12...24Vac. Air probe operating temperature -10+80°C.

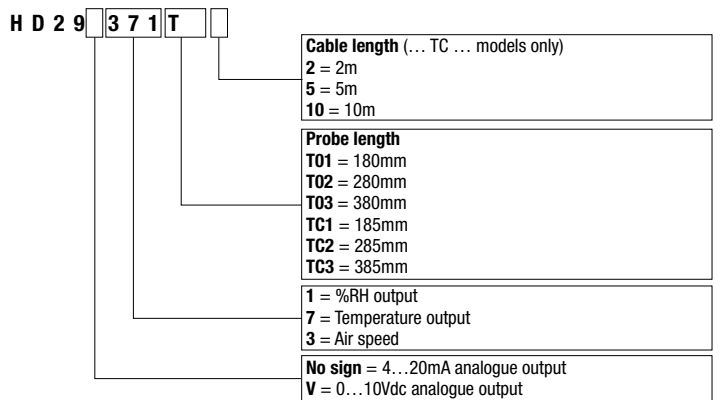

### Probe dimensions:

#### T0 series

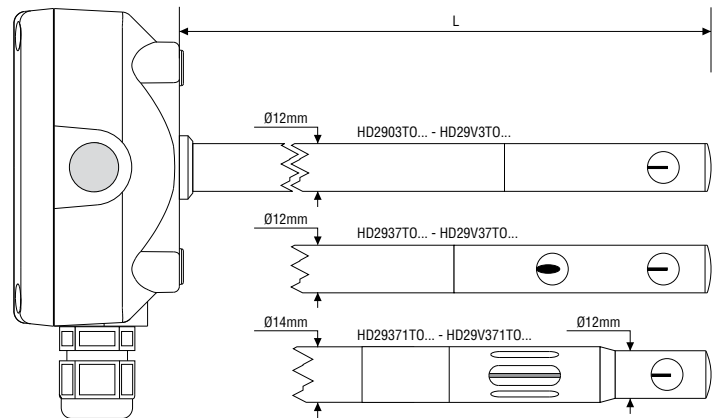

#### TC series

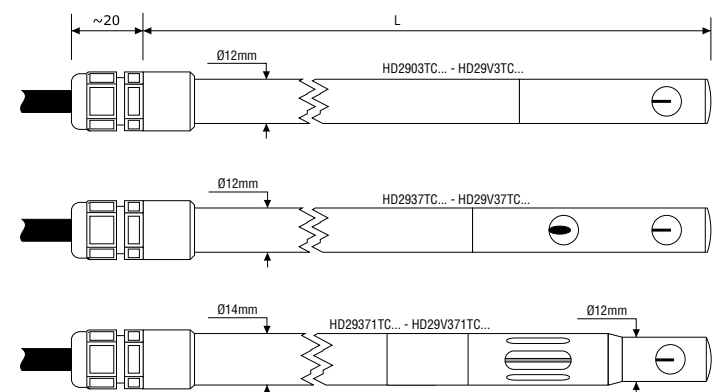

Air speed