

KRACHT

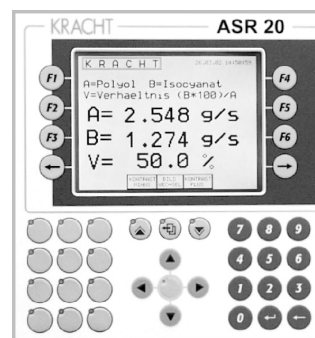

Electronic

**SD 1, AS 8,
ASR 14, ASR 20**

Contents

	Page
List of contents	3
Function and characteristics	4
SD 1	4
Technical data	5
SD 1	5
Type key, dimensions and electrical connection	6
SD 1	6
Function and product characteristics	7
AS 8	7
Technical data	8
AS 8	8
Type key	9
AS 8	9
Dimensions	10
AS 8	10
Flow rate / Volumetric measurement	11
AS 8	11
Flow rate controller	12
AS 8	12
Dosing	13
AS 8	13
Cylinder stroke measurement	14
AS 8	14
Flow rate and sum measurement A2F	15
AS 8	15
Flow rate and difference measurement D2F	16
AS 8	16
Volume and difference measurement D2C	17
AS 8	17
Ratio measurement	18
AS 8	18
Flow rate and ratio measurement V2F	19
AS 8	19
Ratio controller	20
AS 8	20
AS 8 in the desk-top housing	21
AS 8	21
Function and product characteristics	22
ASR 14	22
Technical data	23
ASR 14	23
Dimensions	24
ASR 14	24
Function and product characteristics	25
ASR 20	25
Technical data	26
ASR 20	26
Dimensions	27
ASR 20	27
Product portfolio	28

Plug-in Display Unit SD 1



Function

- The plug-in display unit SD 1 may be used with any KRACHT volume counter which uses a plug-in connection according to DIN 43650.
- The display unit is simply inserted between the plug and the plug socket on the volume counter. The displayed value will be the actual flow rate or the volume. The square wave signal remains available for external processing.
- Volume counters already supplied can be equipped with the plug-in display unit. To achieve this the amplifier card must be removed from the plug.
- The plug-in display unit is freely programmable. All necessary settings can be achieved with 2 keys. The programmed data is stored on an FRAM and therefore saved in case of power failure.
- As an option the SD 1 is available with an analogue output (0 – 20 mA or 4 – 20 mA) proportional to flow rate or volume or with two programmable relay contacts. In both cases, the square wave signals are no longer available.

Function + Product Characteristics SD 1-Service

- The SD 1 Service is a plug-in display unit which may be used with any KRACHT volume counter with plug-in connection according to DIN 43650.
- The display unit is simply put on the plug socket of the flow meter.
- The batterypack supplies the SD 1 and the sensors with power.
- No separate power supply is necessary.
- If the battery drains flat the SD 1 Service can be operated and charged with the enclosed charger.
- The impulse volume is freely programmable.
- All necessary settings can be achieved with 2 keys.
- The programmed data is stored on a FRAM and therefore saved in case of flat batteries.
- With the batterypack an operating time of 30 hours is possible without recharging.

Technical Data SD 1

Processor	PIC 17 C 42
Power unit	
Supply	18 VDC – 28 VDC optional 10 – 19 VDC
Current consumption max.	ca. 120 mA

General data

Display	principle 7 segment LED, 7,62 mm, red display 0.000 ... 9999 with floating decimal point overflow (> 9999): display 9999
Keyboard	2 keys behind the front panel
Housing material	aluminium
Dimensions	height without plug approx. 35 mm, width approx. 60 mm, depth approx. 60 mm
Protection (DIN 40050)	IP 65
Weight	approx. 0.12 kg
Connections	angled connector DIN 43650 (4-pins) polarized

Analogue output

(optional)	current output 0 – 20 mA, 4 – 20 mA load \leq 250 Ohm, at 18 – 28 VDC supply load \leq 50 Ohm, at 10 VDC supply 10 bit resolution, short-circuit-proof
------------	---

Pulse output

Pulse amplitude	incremental signal approx. 0.8 x supply voltage, load depending
Pulse shape with symmetr. output signal	square wave, pulse duty factor/channel 1:1, \pm 15 %
Pulse offset between two channels	90°, \pm 30°
Output power/channel	$P_{a\max}$ = max. 0.3 W short-circuit-proof

Ambient conditions

Operating temperature	0 °C up to + 60 °C
Storage temperature	- 25 °C up to + 85 °C

Technical Data SD 1-Service

Processor	PIC 17 C 42
Current supply	
Accumulator	6 VDC
Working time	approx. 30 hours

Battery charger

Input voltage	controlled by micro-controller 230 VAC
Charging current	max. 700 mA
Charging timer	approx. 4 hours

General characteristics

Display	principle 7 segment LED, 7,62 mm, red display 0.000 ... 9999 with floating point overflow (>9999): display 9999
Keyboard	2 keys on the front side
Housing material	aluminium
Protection (DIN 40050)	IP 65
Weight	approx. 0.46 kg
Connections	angled connector DIN 43650 (4-pins) polarized

Ambient conditions

Operating temperature	0 °C up to + 60 °C
Storage temperature	- 10 °C up to + 85 °C

Type Key SD 1

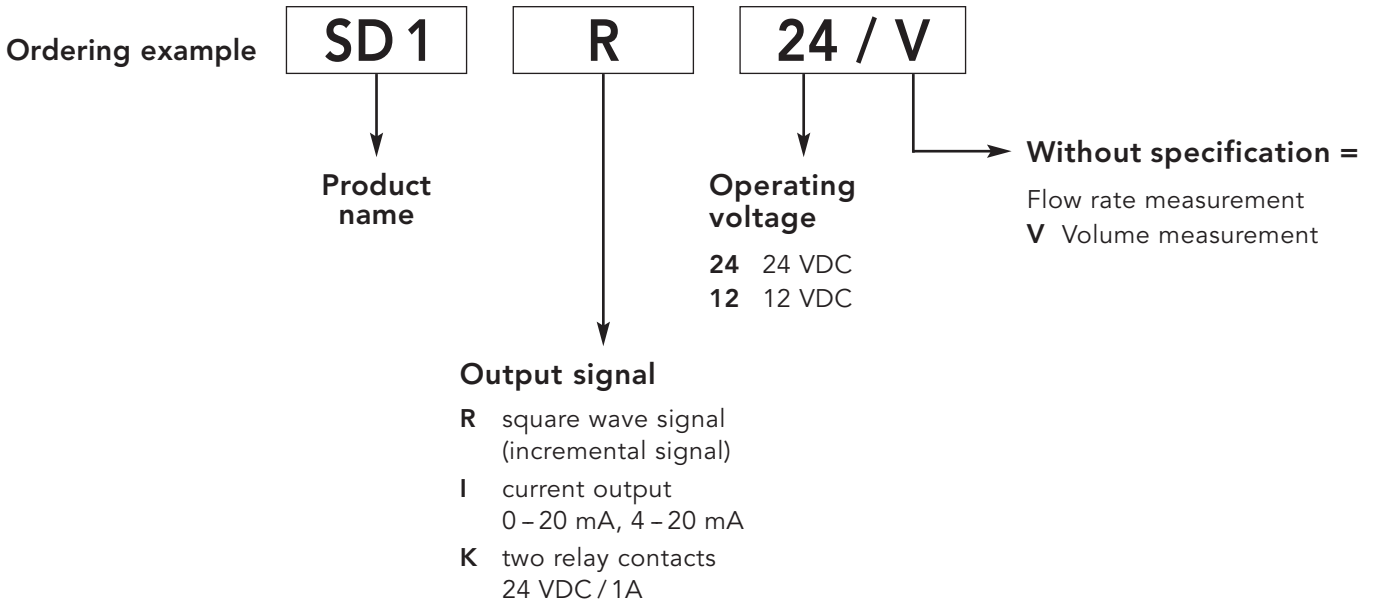

Dimensions SD 1

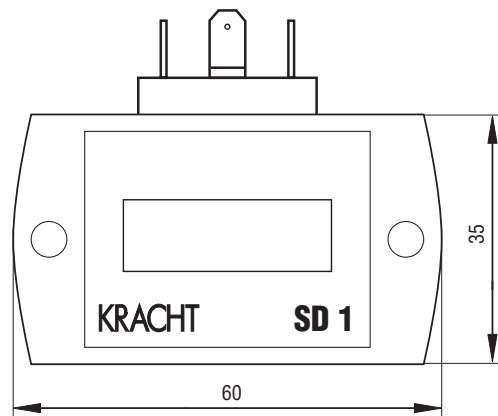

Electrical Connection SD 1

Version: K

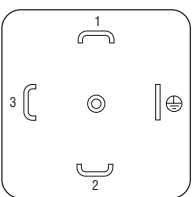

PIN 1 = 12/24 VDC
 PIN 2 = GND
 PIN 3 = Relay 1
 PIN ⊕ = Relay 2

Version: I

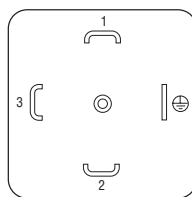

PIN 1 = 12/24 VDC
 PIN 2 = GND
 PIN 3 = 0/4-20 mA
 PIN ⊕ = —

Version: R

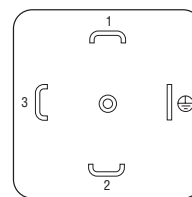

PIN 1 = 12/24 VDC
 PIN 2 = GND
 PIN 3 = Channel 1
 PIN ⊕ = Channel 2

At version V = Volume measurement on Pin ⊕ = "Enable Summation"

Function and Product Characteristics AS 8



Function

- The microcontroller AS 8 processes incremental input signals from KRACHT volume counters and other sensors.
- The input signals are filtered in the unit, interpreted and converted into the values of flow rate and volume.
- The user may choose to have either flow rate or volume displayed.
- Two relays, one analogue output or one serial interface are available for further, external processing.
- As an option, the AS 8 is also available with three keys on the front panel.

Product Characteristics

- EMC construction (electromagnetic compatibility)
- Programmable micro-processor
- Used for KRACHT volume counters and other sensors with 24 volt incremental signals
- Power supply voltage
230/120 V- 50/60 Hz, 24 VDC, 12 VDC
- Integrated sensor power supply 24 VDC - 50 mA
- Flow rate or volume measurement
- Smoothing function by means of a digital filter
- 2 programmable relays
- User-selected analogue output

Current	± 20 mA, 0...20 mA, 4...20 mA
Voltage	± 10 V 0...10 V
- Serial interface RS 232
- Selectable time basis (sec, min, hrs)
- Selectable units for display
- Enclosure with dimensions according to DIN

Technical Data AS 8

Processor	PIC 17C42
Supply	230 VAC, + 6% ... - 10% / 50 - 60 Hz, optional 120 VAC, 24 VDC, 12 VDC
Power input (power consumption)	approx. 3.5 W
Sensor supply	24 VDC \pm 20%, 50 mA
General data	
Display	principle: 7 segment LED, 13.2 mm, red display: 0.000 ... 9999 with floating decimal point overflow (>9999): display 9999 overflow (<-9999): display -9999 status indicator: LEDs K1 and K2 for relays 1 and 2
Keyboard	three keys behind the front panel, optional keys on front panel
Housing	for switch panel plug-in unit made of plastic
Panel frame	96 x 48 mm, DIN 43700
Insertion depth	ca. 122 mm with plug board
Panel cutout	92 x 45 mm, tolerance + 0.8 x + 0.6 mm
Protection (DIN 40050)	IP 54 in appropriate switch panel mounting
Weight	approx. 0.4 kg
Connections	15 pins terminal connecting block
2 relay contacts	one normally-open-contact switching-time each
2 digital inputs	
Input impedance	\geq 7500 Ohm
Input amplitude	low \leq 9 volt, high \geq 12 volt
Switching time	typ. 1 ms
1 analogue output	
Voltage output	current or voltage output adjustable by means of jumper \pm 10 volt, 0 - 10 volt, 2 - 10 volt / load \geq 1 kOhm, or 10 bit resolution, short-circuit-proof
Current output	\pm 20 mA, 0 - 20 mA, 4 - 20 mA / load \leq 250 Ohm, 10 bit resolution, short-circuit-proof
1 volume counter input	
Input impedance	\geq 7500 Ohm
Input amplitude	low \leq 9 volt, high \geq 12 volt
Rate-of-flow principle of measurement	period length measurement (rising tooth flank)
Maximum input frequency	1Hz ... 2500 Hz
Measurement range totalizer	2×10^9 pulses
Serial interface	
RS 232	cable length \leq 15 m
Input voltage	max. \pm 30 V
Input current	typ. \pm 3 mA at \pm 9 V input voltage
Output current	typ. \pm 3 mA
Adjustment (selection)	9600 baud, 8 bit, no parity, 1 stop bit
Cable	shielded data cables recommended
Ambient conditions	
Operating temperature	0 °C up to + 60 °C
Storage temperature	-25 °C up to + 85 °C

Type Key AS 8

Ordering example

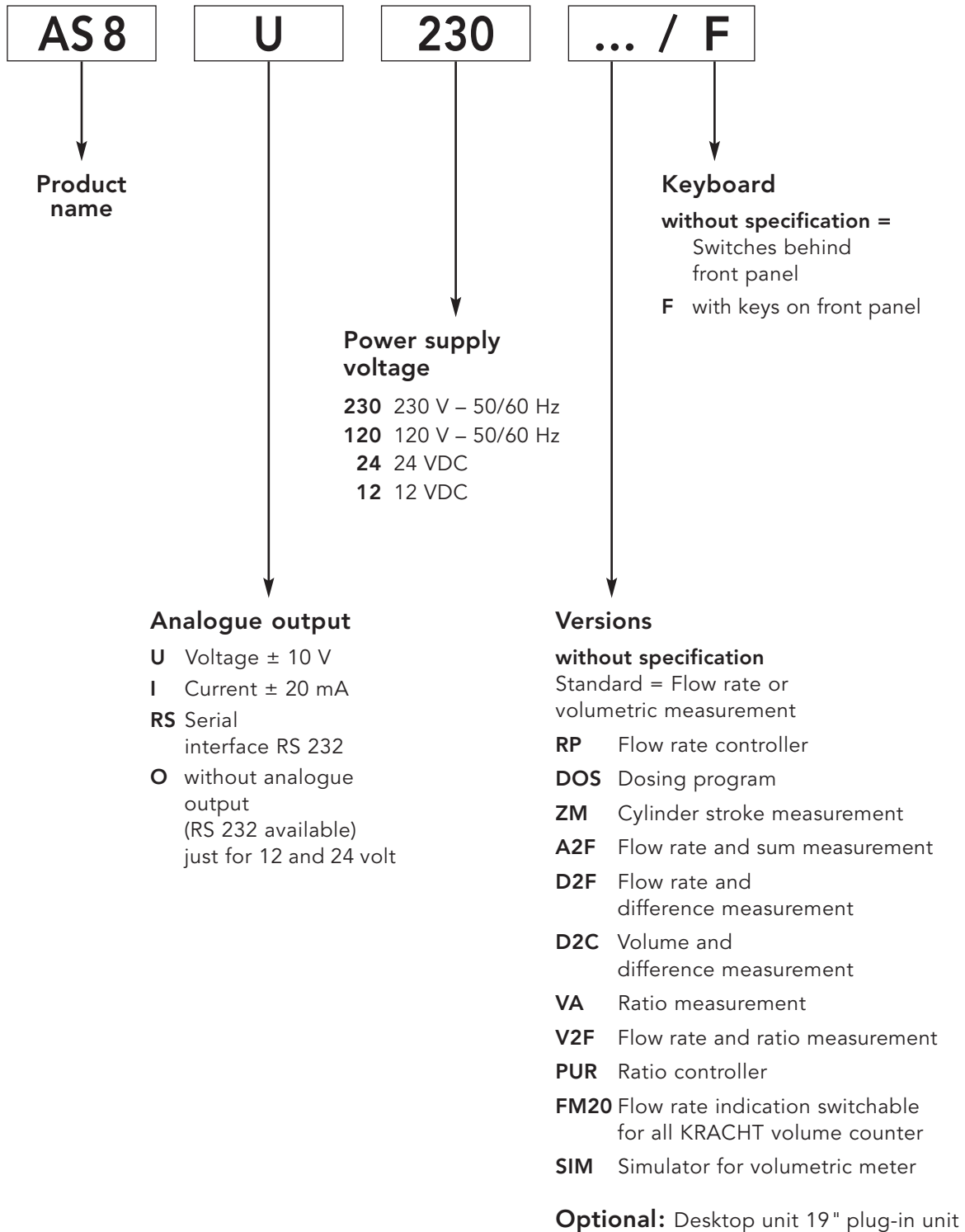

Dimensions AS 8

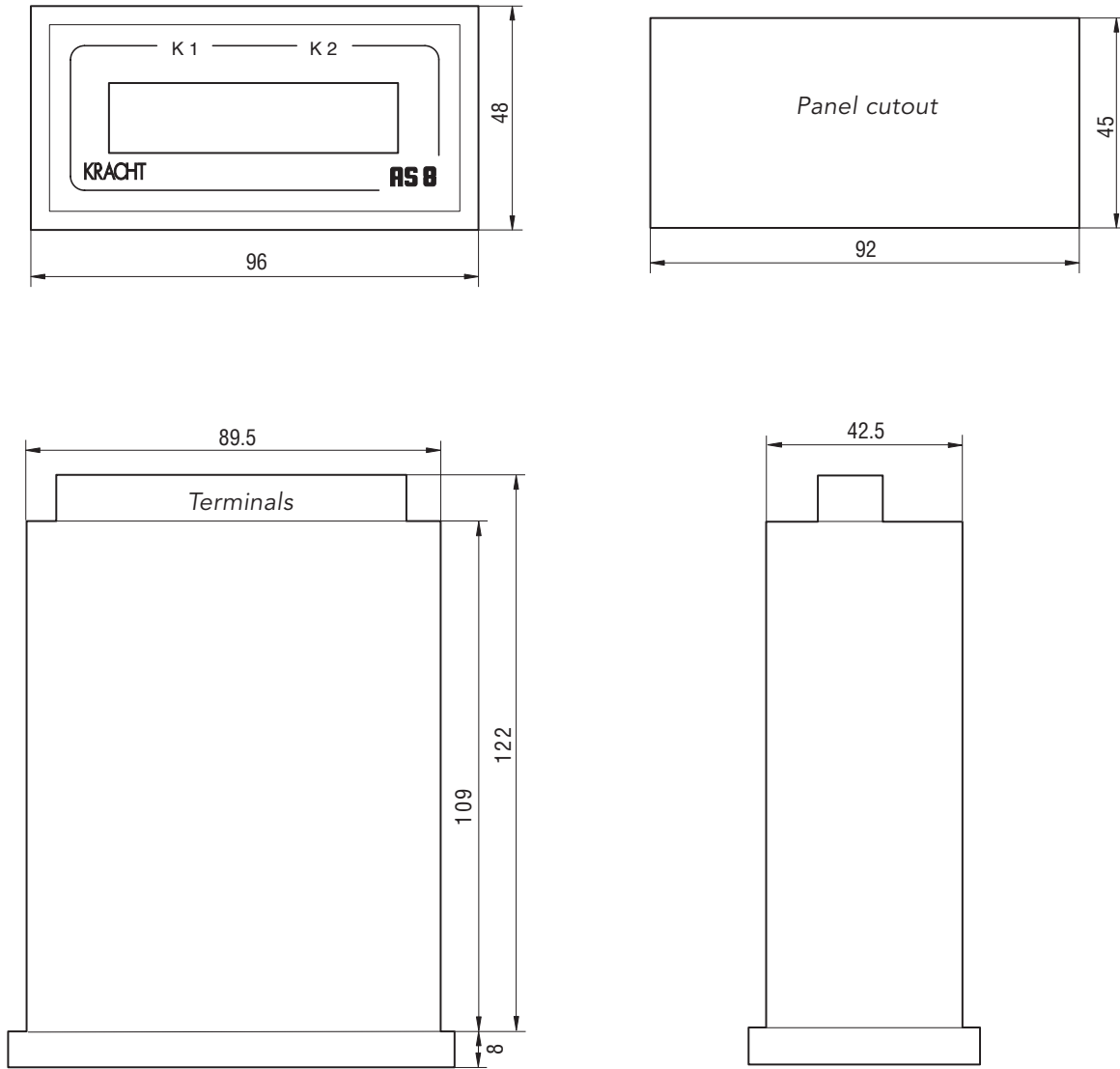

Dimensions in mm

Flow Rate Measurement AS 8 - Standard

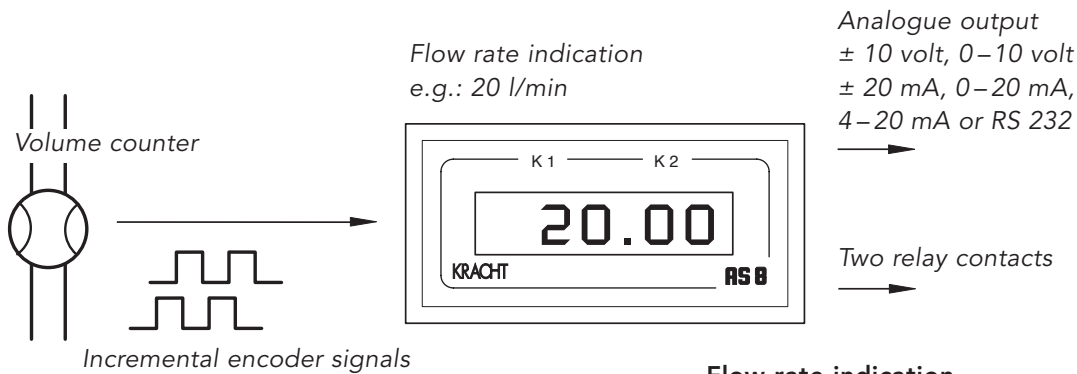

Flow rate indication

- The incremental input signals are filtered, converted and processed by the microcontroller to give the corresponding flow rate.
- Any of the following physical units can be set for the indicator reading:
l/h, l/min, l/s, or US gal/hr, US gal/min, US gal/s.

Volumetric Measurement AS 8 - Standard

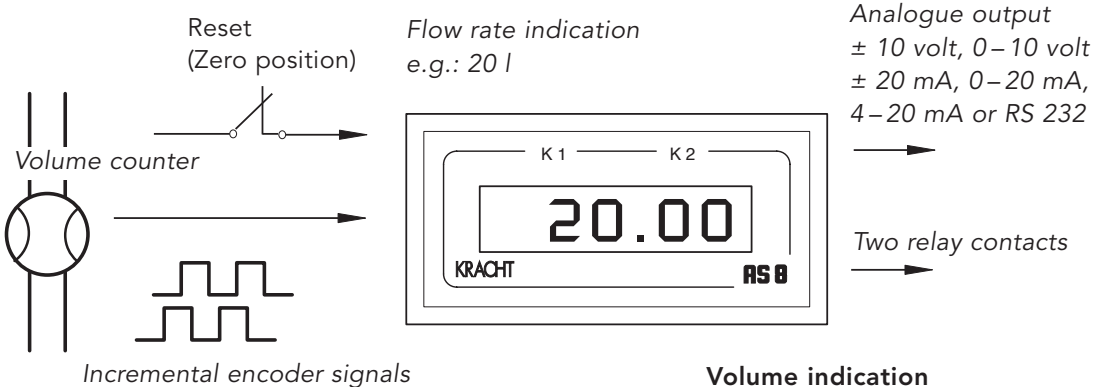

Volume indication

- The incremental input signals are summarized and converted to the dimensions of volume by the microcontroller, using a programmable factor.
- The physical units l and US gal can be set for display.
- A 24 volt digital input enables the summation to be reset to zero.

Functional Characteristics AS 8 - Standard

- The standard version AS 8 is an indication and control device for dynamic flow rate and volume measurement. The setting is made by means of three keys, which are accessible behind the front cover. Optional via keys on front panel (version /F).
- The switch-over between the display units is made by means of DIP switches, located behind the front cover.
- Two programmable relays, an analogue output, or an RS 232 serial interface, are available for further external processing.
- The integrated 24 VDC transducer supply enables the volume counter to be directly connected.
- The type AS 8 series measuring devices are available as built-in control panel units, as bench units or as 19" rack-mounted units.

Flow Rate Controller AS 8 - RP

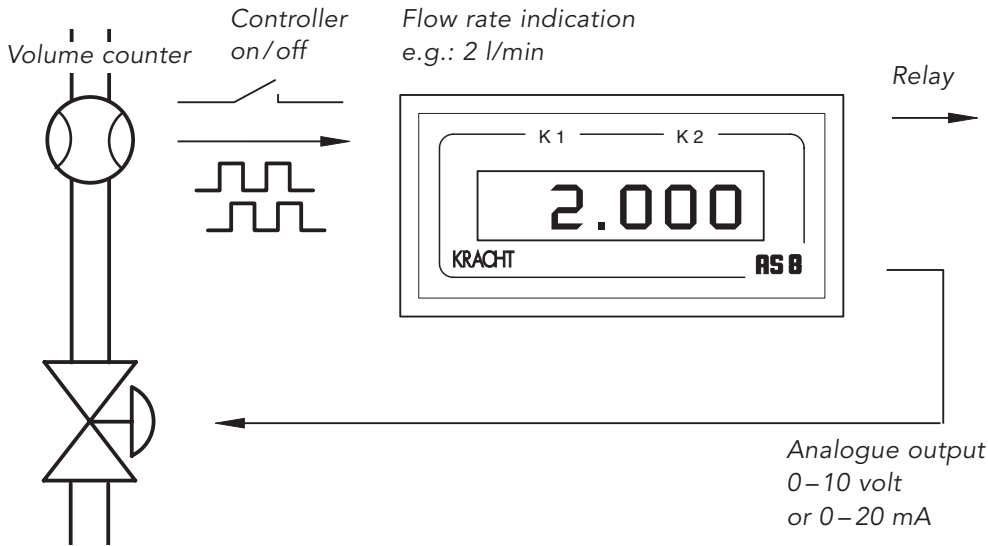

Flow rate controller

- The AS 8-RP Flow rate controller version controls the flow rate of a component. The required flow rate is set on the AS 8. The flow rate is detected by the volume counter and fed to the AS 8 as a square-wave signal.
- The controller output is connected to a continuously variable valve via a position amplifier, or is used to control the speed of a dosing pump.

Rotational Speed Controller AS 8 - RP

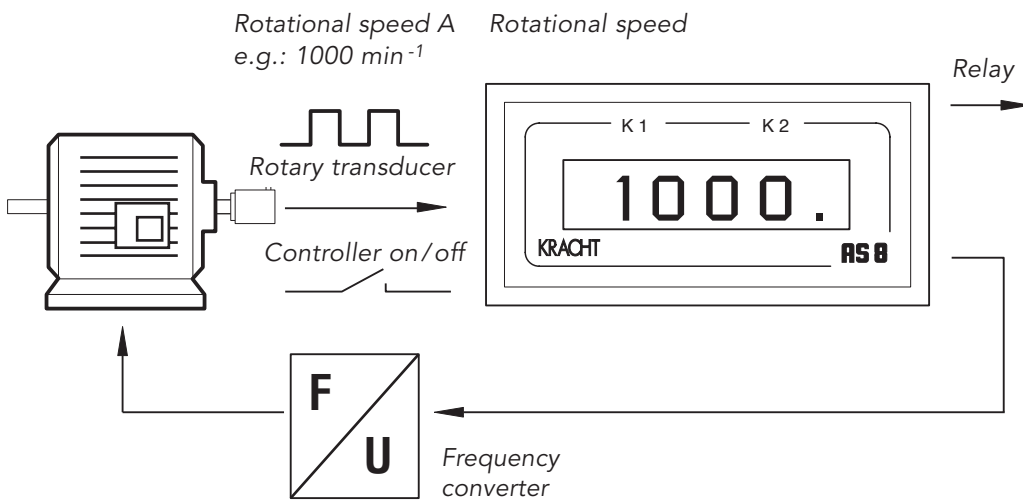

Rotational speed controller

- A further application example is that of rotational speed regulation. The required speed is set on the AS 8. The actual rotational speed is detected by the rotary transducer and fed to the AS 8 as a square-wave signal.
- The controller output is connected to the motor via a frequency converter and used to control the rotational speed

Functional Characteristics AS 8 - RP

- Two relay contacts enable the overshoot of permissible error bandwidths to be signalled.
- Programming and setting is carried out by means of three keys which are accessible on removal of the front cover. Optional via keys on front panel (version /F).
- The integrated 24 VDC transducer supply enables the direct connection of the volume counter.
- The type AS 8 series measuring devices are available as built-in control panel units, as bench units, or as 19" rack-mounted units.

Dosing AS 8 - DOS

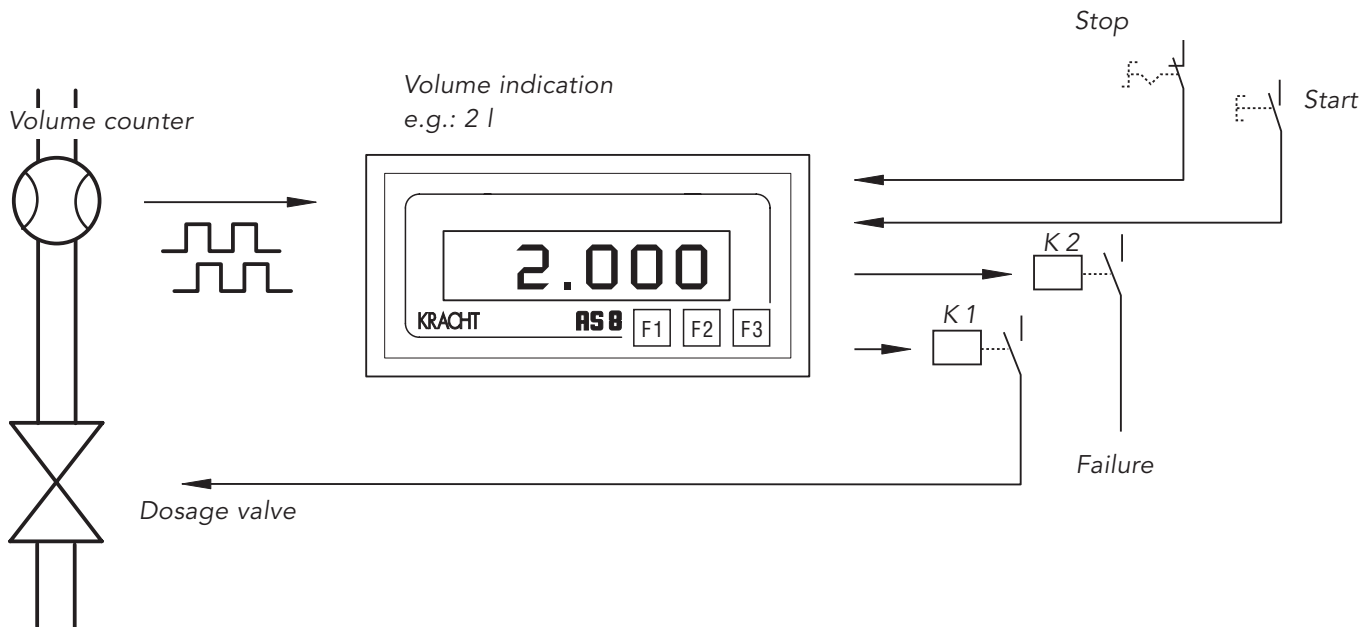

Functional Characteristics AS 8 - DOS

- The AS 8 dosing version is especially designed for employment in dosing lines. It allows one volume counter to be connected.
- 6 dosages (programmes) can be stored in the AS 8. Specific dosages are called up via the three keys on the front panel. The input values are arranged in menus.
- The filling process is started by the digital input. The AS 8 resets the last dosage quantity and switches the dosage valve. The volume counter measures the flow and delivers square wave signals to the AS 8.
- The AS 8 sums the input signals. When the quantity is reached the dosage valve will be switched.
- The second relay contact enables the indication of faulty dosages.
- The settings are made by using the three keys on the front panel. The input values are arranged in menus.
- The integrated 24 VDC sensor supply enables direct connection to the volume counter.
- The type AS 8 measuring devices are available as built-in control panel units, as desk-top units, or as 19" rack-mounted units

Cylinder Stroke Measurement AS 8 - ZM

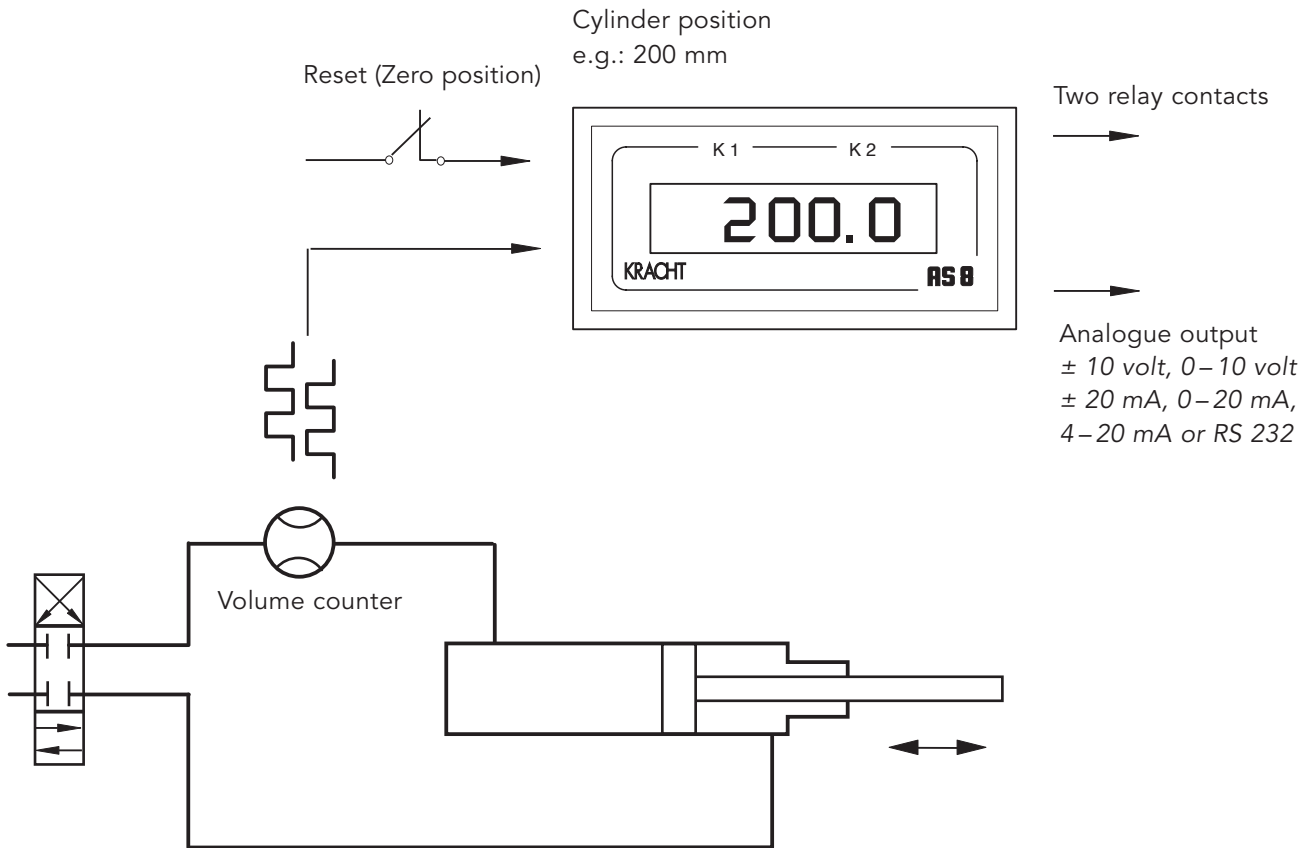

Functional Characteristics AS 8 - ZM

- The cylinder stroke measurement version of the AS 8 enables an indirect measurement to be made of hydraulic drive movements, in combination with a volume counter.
- In this system, the volume counter is installed in an operating line, to generate pulses which are proportional to the flow rate and to indicate the direction of flow.
- The electrical pulses are converted by the micro-controller into the physical dimensions of flow rate and volume, or stroke and velocity.
- Erroneous measurements, due to leakage at the end positions, can be prevented by means of a programmable blocking frequency. The signals are only processed when the flow rate exceeds the blocking frequency.
- Two relays, an analogue output or an RS 232 interface, are available for additional external processing.
- Programming and setting is carried out by means of three keys, which are accessible behind the front cover.
- The integrated 24 VDC transducer supply enables the direct connection of the volume counter.
- The type AS 8 series measuring devices are available as built-in control panel units, as bench units, or as 19" rack-mounted units

Flow Rate and Sum Measurement AS 8 - A2F

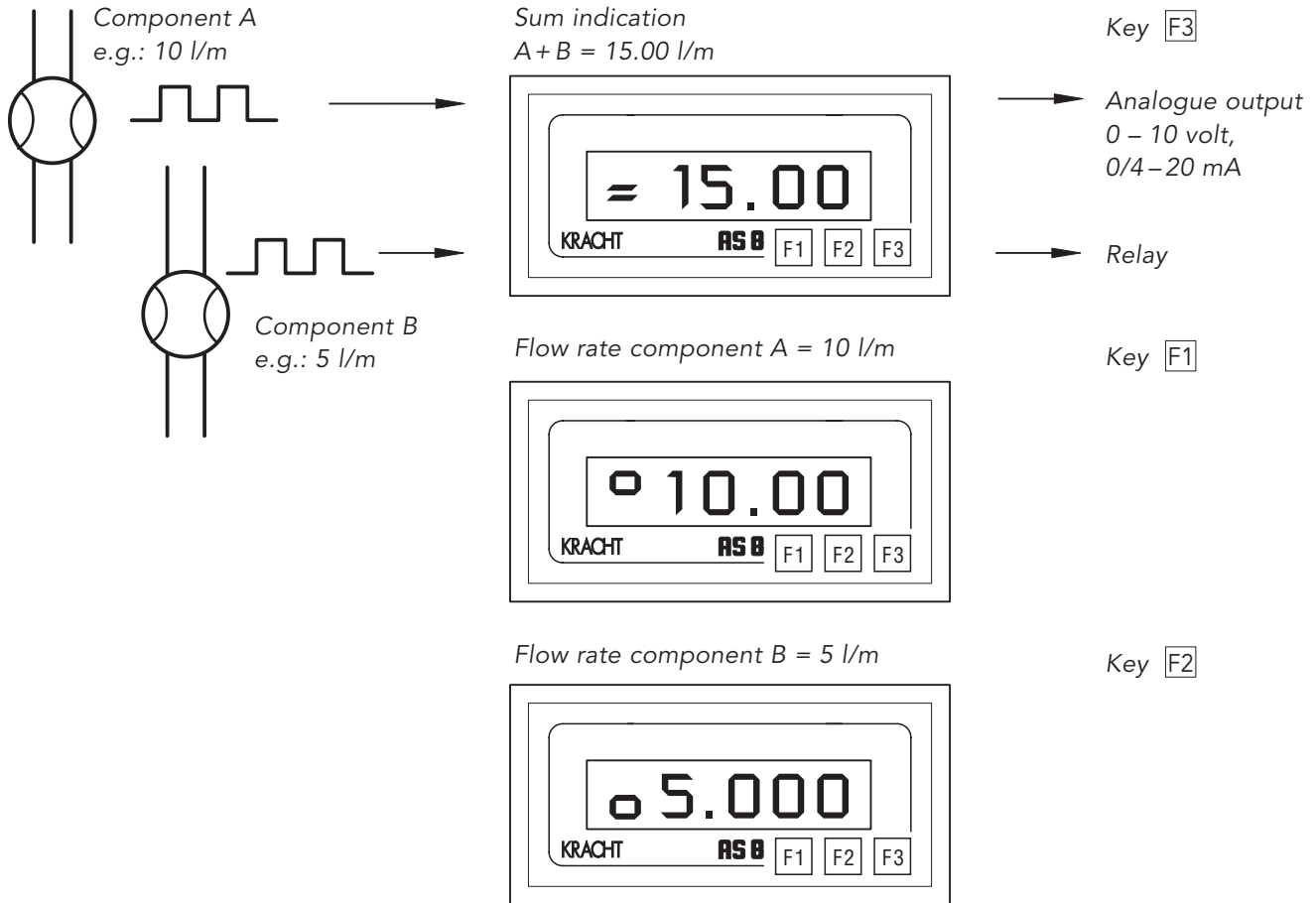

Functional Characteristics AS 8 - A2F

- Two volume counters could be connected to the AS 8-A2F. The AS 8 shows the flow rate of component A and B and the sum A + B.
- The different indications are switched by the keys **F1**, **F2** and **F3**.
- For each volume counter a density factor can be put in.
- One square-wave signal is required of each volume counter. The input signals are filtered, converted and processed by the microcontroller to give a sum.
- The settings are made using the three keys on the front panel. The input values are arranged in menus.
- Two relay contacts, an analogue output or an RS 232 interface are available for additional external processing.
- The integrated 24 VDC transducer supply enables the direct connection of the volume counter.
- The type AS 8 series measuring devices are available as built-in control panel units, as bench units, or as 19" rackmounted units.

Flow Rate and Difference Measurement AS 8 - D2F

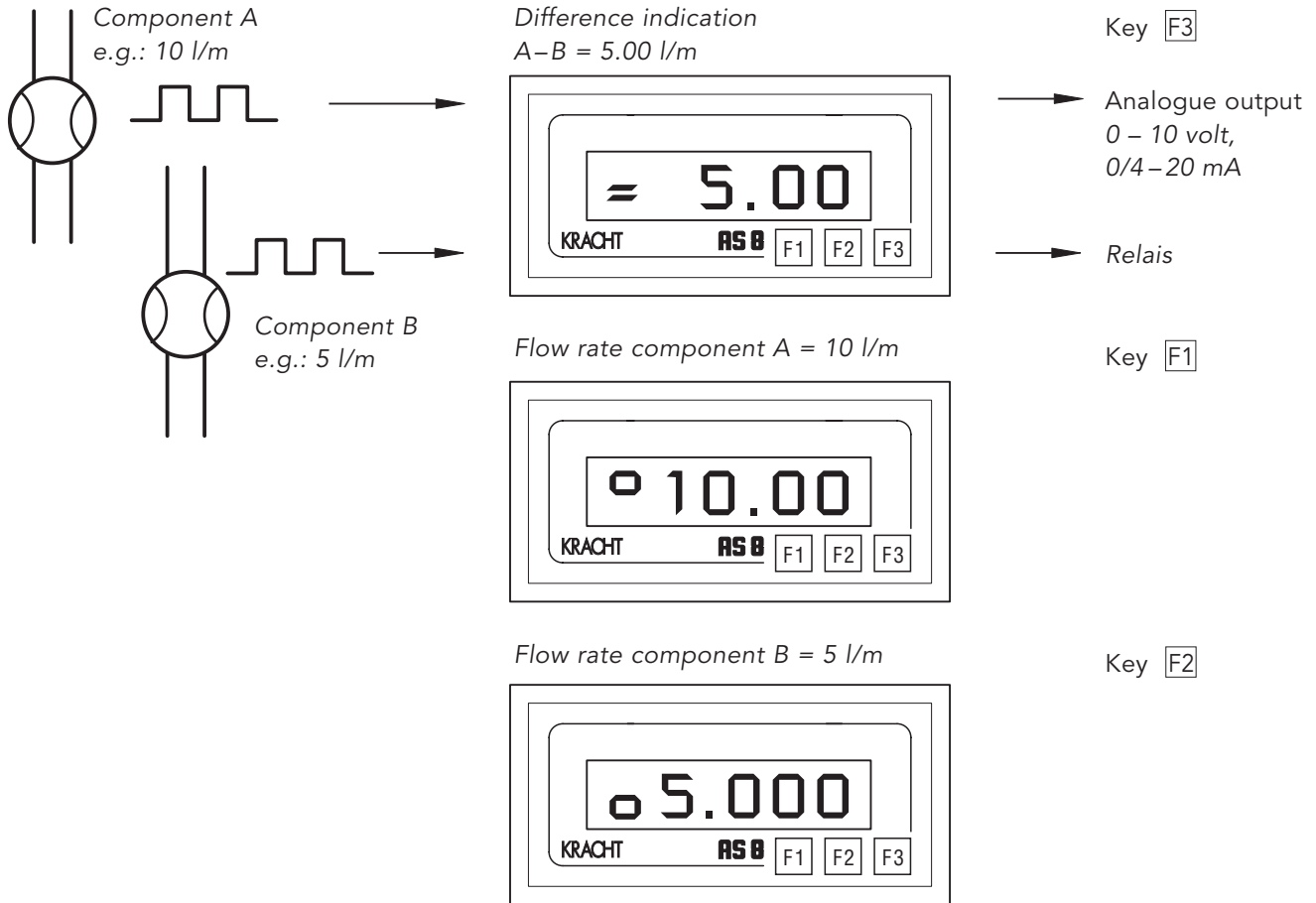

Functional Characteristics AS 8 - D2F

- Two volume counters could be connected to the AS 8-D2F. The AS 8 shows the flow rate of component A and B and the difference A-B.
- The different indications are switched by the keys **F1**, **F2** and **F3**.
- For each volume counter a density factor can be input.
- One square-wave signal is required of each volume counter. The input signals are filtered, converted and processed by the microcontroller to display the difference.
- The settings are made using the three keys on the front panel. The input values are arranged in menus.
- Two relay contacts, an analogue output or an RS 232 interface are available for additional external processing.
- The integrated 24 VDC transducer supply enables the direct connection of the volume counter.
- The type AS 8 series measuring devices are available as built-in control panel units, as bench units, or as 19" rackmounted units.

Volume and Difference Measurement AS 8 - D2C

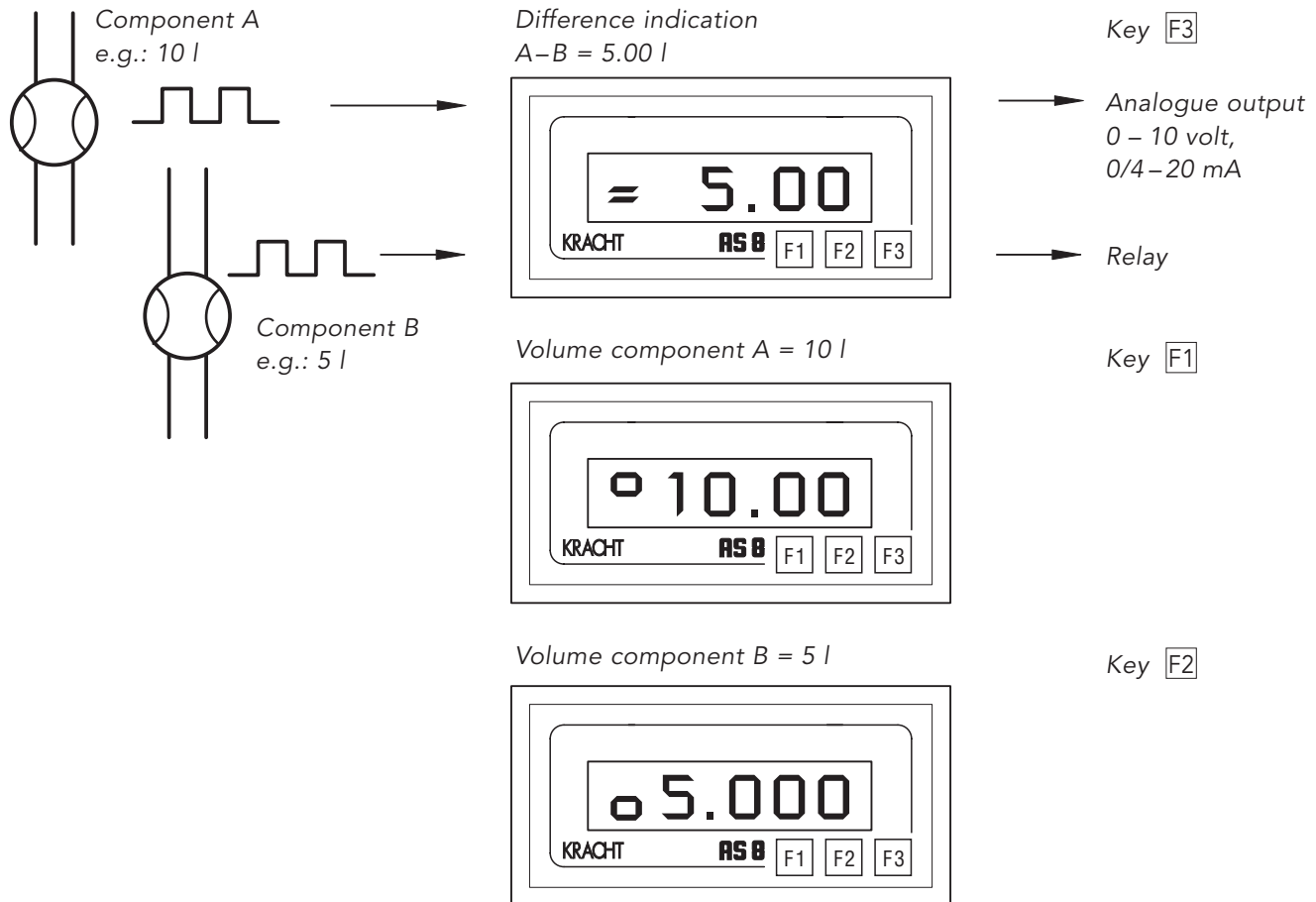

Functional Characteristics AS 8 - D2C

- Two volume counters could be connected to the AS 8-D2C. The AS 8 shows the volume of component A and B and the difference A–B.
- The different indications are switched by the keys **F1**, **F2** and **F3**.
- For each volume counter a density factor can be input.
- One square-wave signal is required of each volume counter. The input signals are filtered, converted and processed by the microcontroller to display the difference.
- The settings are made using the three keys on the front panel. The input values are arranged in menus.
- Two relay contacts, an analogue output or an RS 232 interface are available for additional external processing.
- The integrated 24 VDC transducer supply enables the direct connection of the volume counter.
- The type AS 8 series measuring devices are available as built-in control panel units, as bench units, or as 19" rackmounted units.

Mixture ratio measurement AS 8 - VA

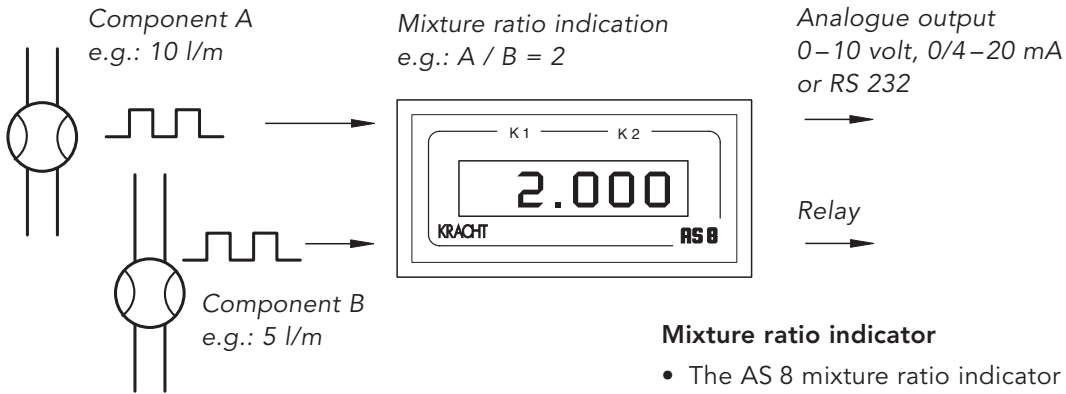

Mixture ratio indicator

- The AS 8 mixture ratio indicator displays the mixture ratio of two components.
- A square-wave signal is required from each volume counter. The input signals are filtered, converted and processed by the micro-controller to give a mixture ratio.

Rotational Speed Ratio Measurement AS 8 - VA

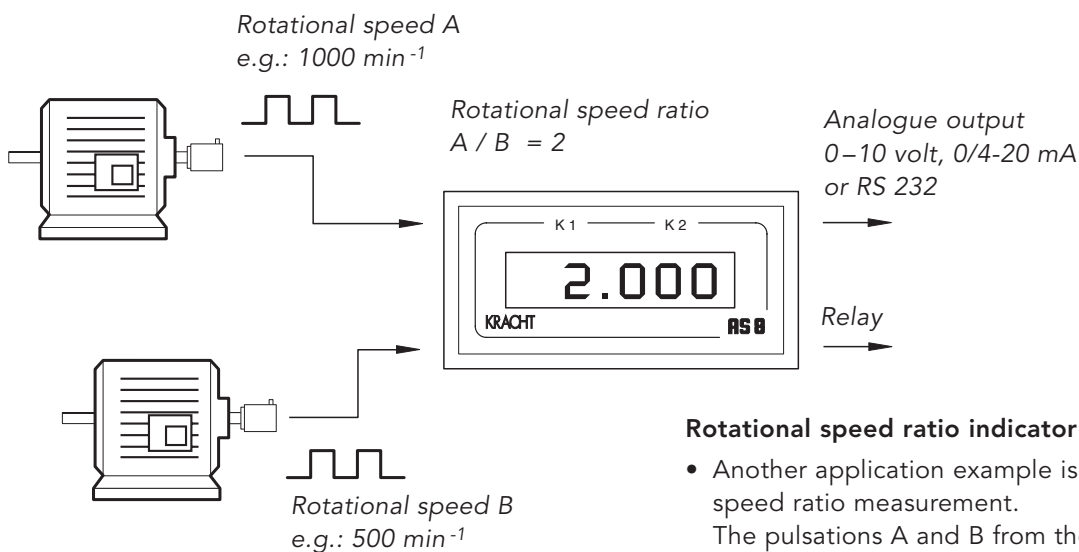

Rotational speed ratio indicator

- Another application example is that of rotational speed ratio measurement. The pulsations A and B from the rotary transducers are detected and indicated on the AS 8 as a rotational speed ratio.

Functional Characteristics AS 8 - VA

- Two programmable relays, an analogue output, or an RS 232 serial interface, are available for further external processing.
- The programming and settings are achieved via three keys, accessible on removal of the front cover. Optional via keys on front panel (version /F).
- The integrated 24 VDC transducer supply enables the direct connection of the volume counter.
- The type AS 8 series measuring devices are available as built-in control panel units, as bench units, or as 19" rack-mounted units.

Flow Rate and Ratio Measurement AS 8 - V2F

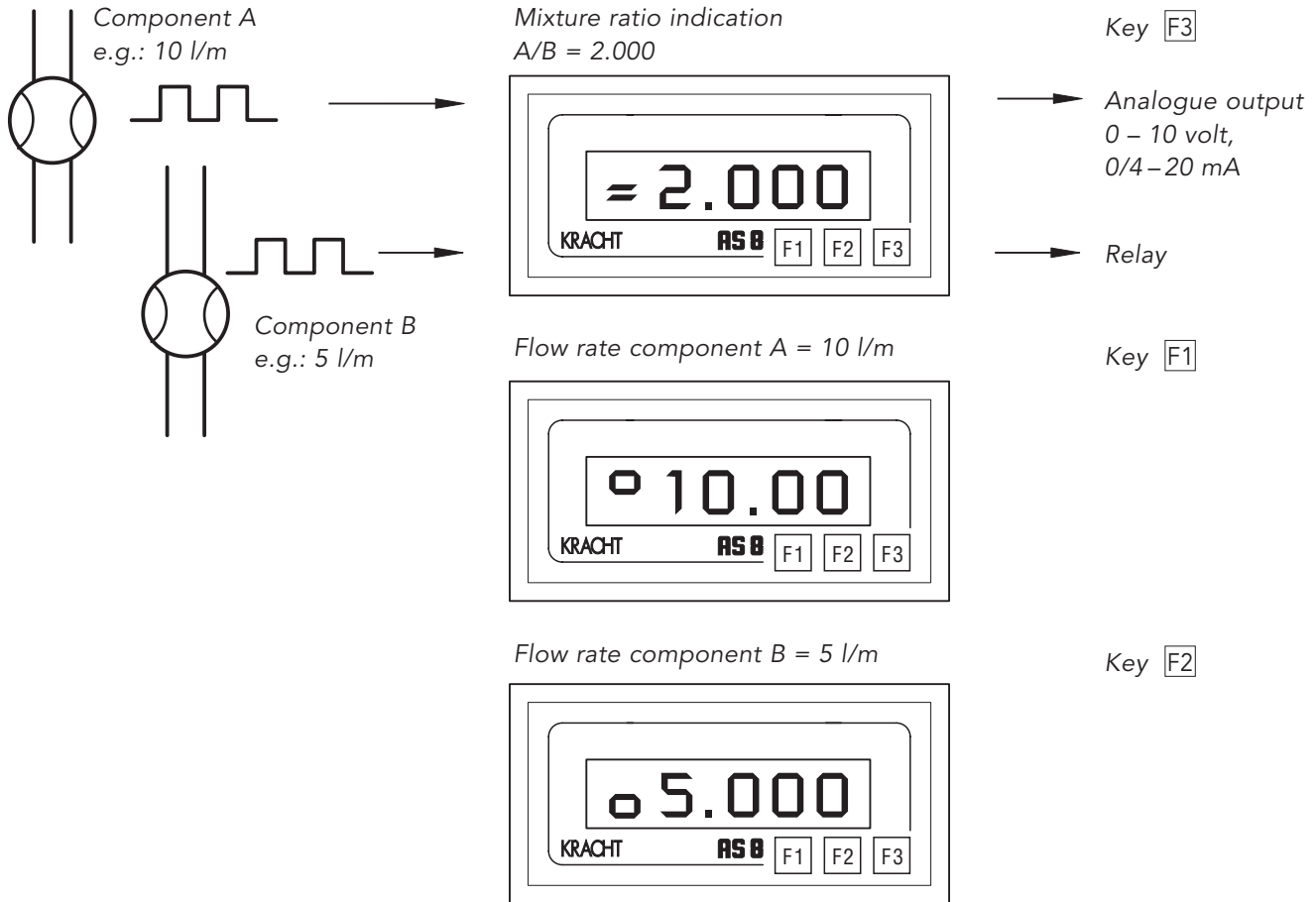

Functional Characteristics AS 8 - V2F

- Two volume counters could be connected to the AS 8-V2F. The AS 8 shows the flow rate of component A and B and the mixture ratio A/B.
- The different indications are switched by the keys **F1**, **F2** and **F3**.
- For each volume counter a density factor can be input.
- One square-wave signal is required of each volume counter. The input signals are filtered, converted and processed by the microcontroller to give a mixture ratio.
- The settings are made using the three keys on the front panel. The input values are arranged in menus.
- Two relay contacts, an analogue output or an RS 232 interface are available for additional external processing.
- The integrated 24 VDC transducer supply enables the direct connection of the volume counter.
- The type AS 8 series measuring devices are available as built-in control panel units, as bench units, or as 19" rackmounted units.

Ratio Controller AS 8 - PUR

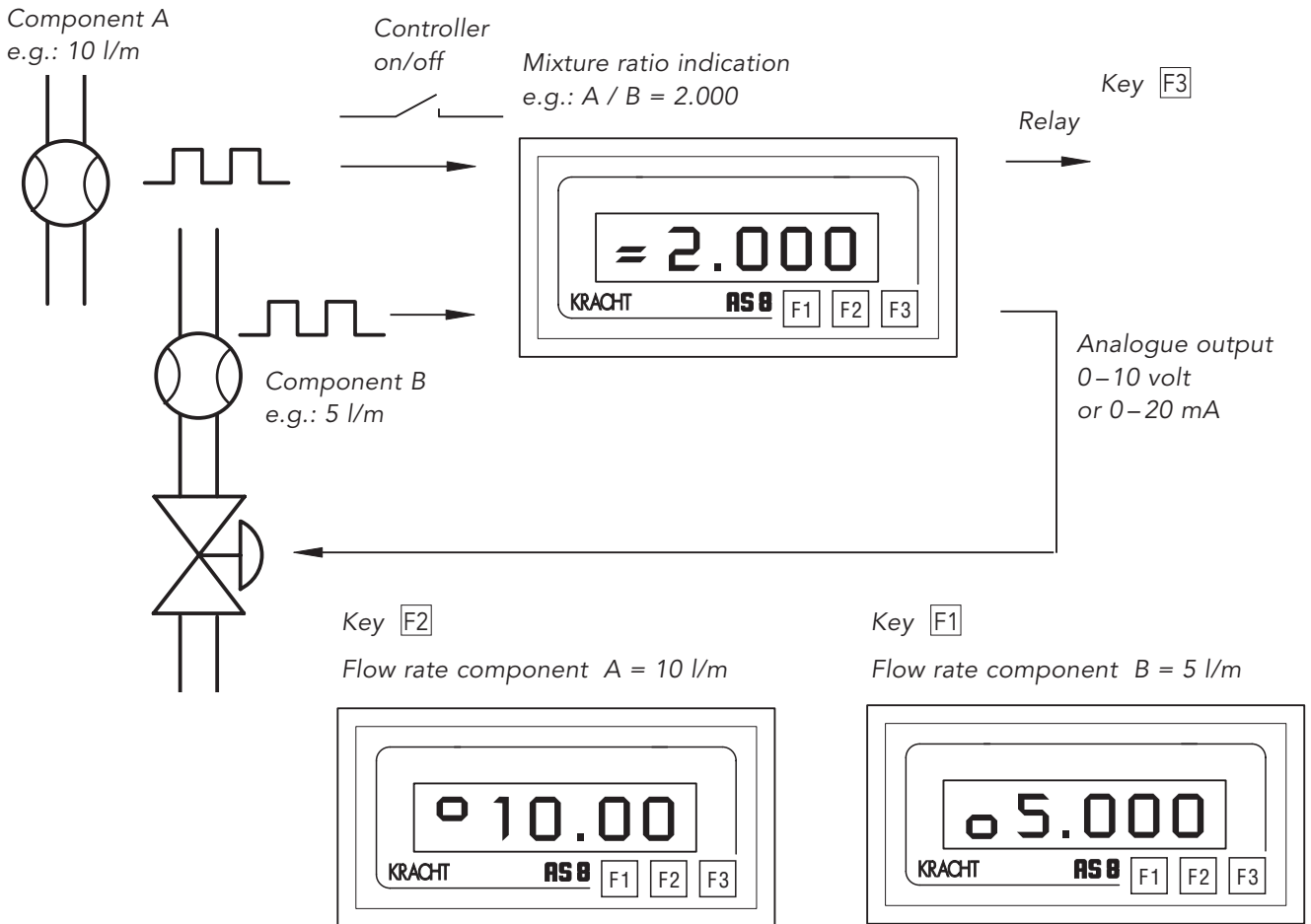

Functional Characteristics AS 8 - PUR

- The ratio controller version of the AS 8 controls the mixture ratio of two components and shows the flow rate of the components A and B as well as the mixture ratio A/B.
- The different indications are switched by the keys **F1**, **F2** and **F3**.
- The volumetric flows are detected by the volume counter and fed to the AS 8 as square-wave signals. The input signals are filtered, converted and processed by the microcontroller, to give a mixture ratio. The controller output is either directly connected, or connected via a position amplifier, to a continuously controllable valve, or used to control the speed of a dosing pump.
- Two relay contacts enable the overshoot of permissible error bandwidths to be signalled.
- All settings are made using three keys, which are accessible behind the front cover. Optional via keys on front panel (version /F). The input values are arranged in menus.
- The integrated 24 VDC transducer supply enables the direct connection of the volume counter.
- The type AS 8 series measuring devices are available as built-in control panel units, as bench units, or as 19" rackmounted units.

AS 8 in the Desk-top Housing

The desk-top housing is available with analogue output or serial interface.

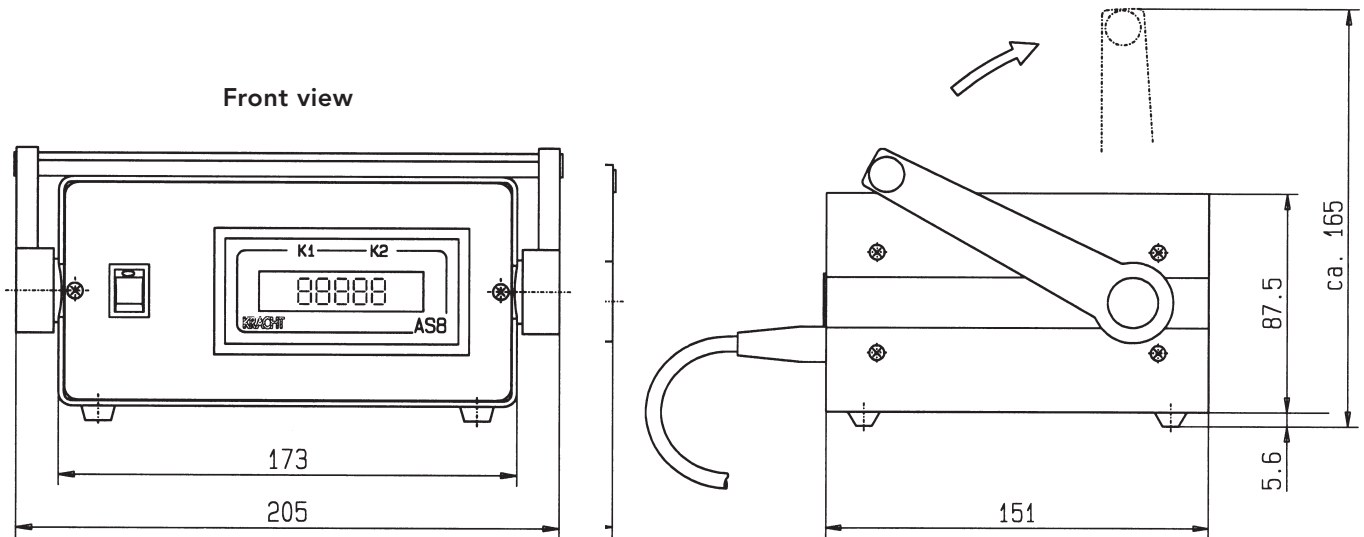

Dimensions in mm

Rear view with RS 232

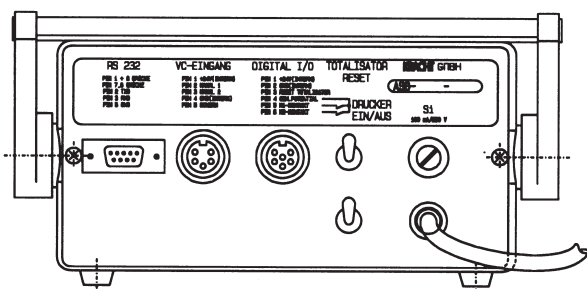

Rear view with analogue output

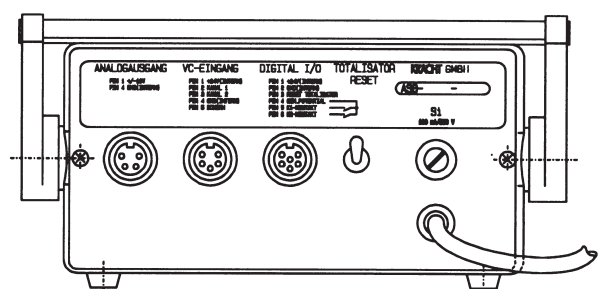

Function and Product Characteristics ASR 14

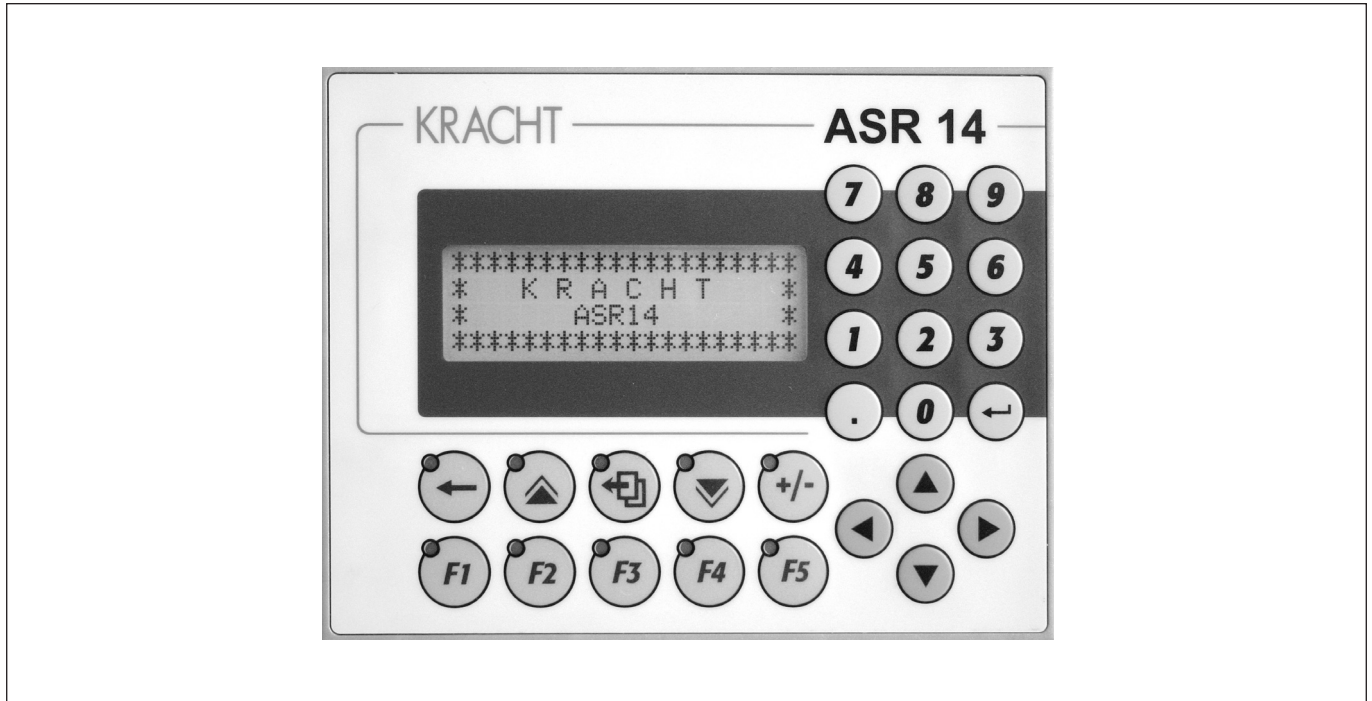

Function ASR 14

- The ASR 14 integrates controlling, operating and visualizing.
- The ASR 14 processes incremental signals.
- A CAN-Bus Interface allows the connection of further In-/Output channels.
- The programming of the ASR 14 can be adapted optimally for the specific applications.
- Optimal for the controlling of batching applications (e.g. metering of gear box oil).

Product Characteristics ASR 14

- LC-Display with illuminated background with 4 x 20 characters.
- Used for KRACHT flow meters and other sensors with 24 V incremental signals.
- Power supplies 24 V DC.
- 16 digital inputs, 2 of these are counter inputs with one channel or 1 counter input two channels.
- 16 digital outputs.
- For flow rate measurement and totalizing.
- With RS232 interface.
- With CAN-Bus-interface.

Technical Data ASR 14

Power unit

Power supply	24 V DC
Power consumption	max. 6 W

General characteristics

Display	LC-Display, black/white, 4 x 20 characters, illuminated background
Keyboard	26 function keys (10 with LED)
Housing	housing for switch panel plug-in
Panel frame	153 x 120 x 46.1 mm (w x h x d)
Insertion depth	41.6 mm
Panel cutout	141 x 108 mm
Protection	IP 65 (front side)
Weight	0.5 kg

Operating conditions

Ambient temperature	0 °C to 50 °C
Humidity when operating	10 % to 90 % (not condensating)
Storage temperature	-20 °C to 60 °C
Humidity at storage	5 % to 95 % (not condensating)

Inputs and outputs

Digital Inputs	16; 2 of these are counter inputs (one channel)
Input voltage	24 V DC
Input current 24 V	ca. 10 mA
Digital outputs	16
Switching voltage	24 V DC
Output current	0.5 A

Interfaces

Type 1	RS232
Execution	9pins DSUB-connector
Potential separation	no
Max. baud rate	115.2 kBits/s
Type 2	CAN-bus
Execution	9pins DSUB-connector
Potential separation	yes

Dimensions ASR 14

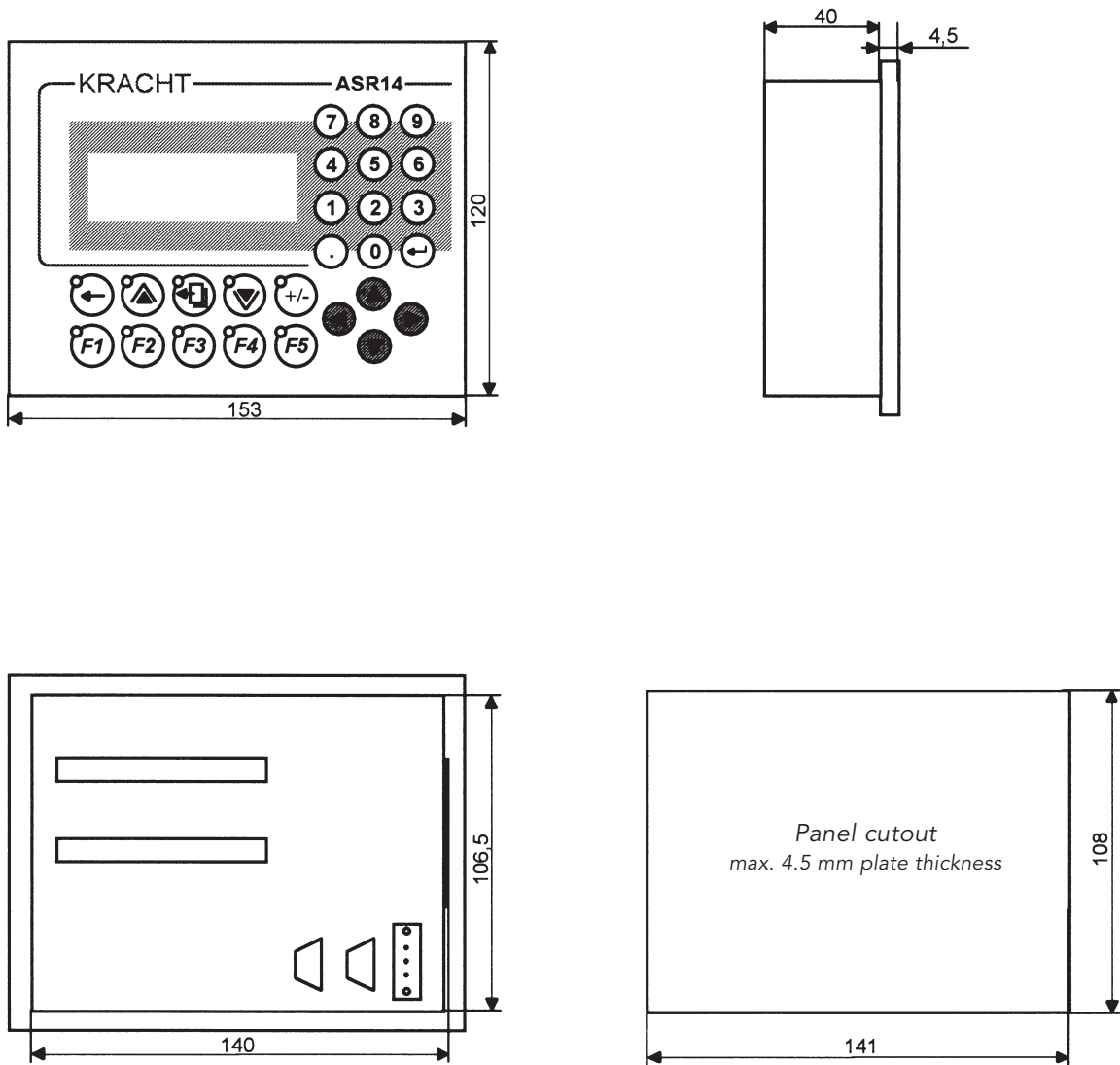

Dimensions in mm

Function and Product Characteristics ASR 20

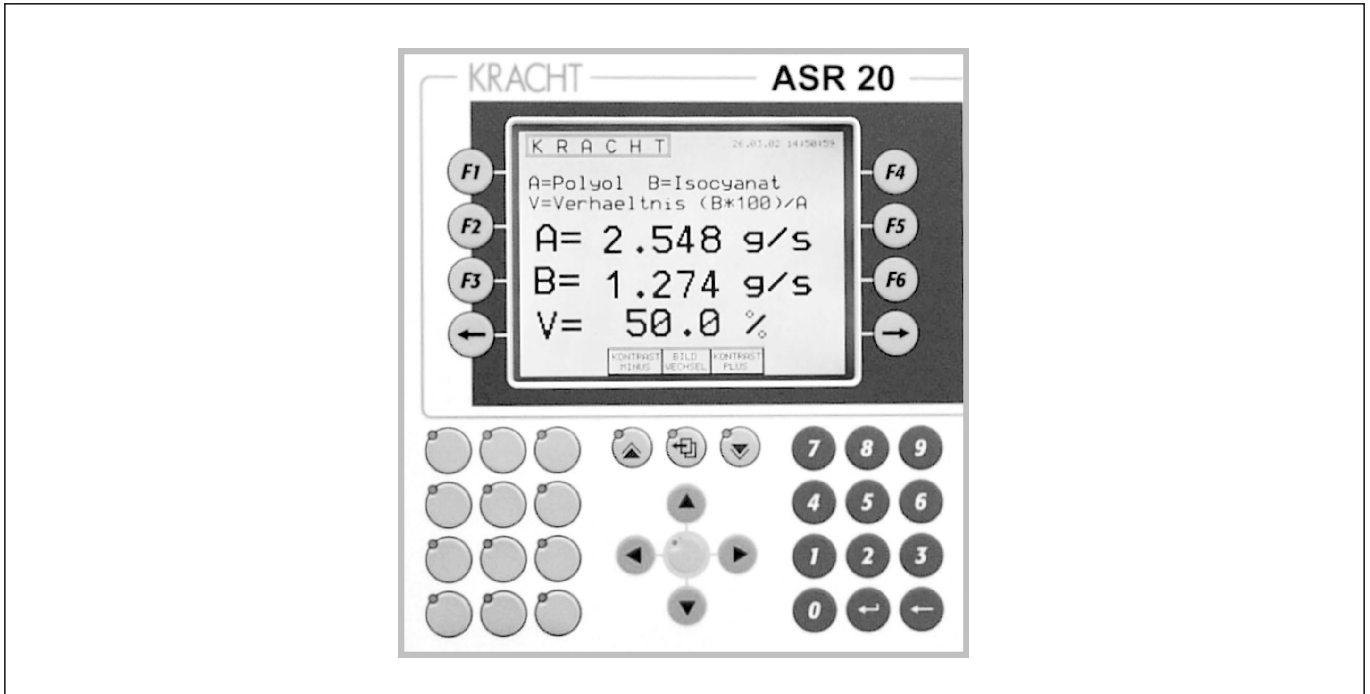

Function ASR 20

- The ASR 20 is a combination of operator panel and controller in one device. Many flow specific applications may be controlled.
- The ASR 20 processes incremental signals.
- Standardized programs are available for a wide variety of applications.
- The number of inputs and outputs can be adjusted to the specific application.
- Relay contacts, analogue outputs and serial interfaces are available for further external processing.
- The measured values are indicated on a LC-display.

Product Characteristics ASR 20

- Used for KRACHT volume counters and other sensors with 24 V incremental signals.
- Up to 6 additional modules can be used.
- Analogue inputs allow the connection of pressure transducers, temperature sensors and the like.
- The input signals are filtered in the unit, interpreted and converted into the physical sizes of flow rate and volume.

Technical Data ASR 20

Power unit

Supply	24 VDC \pm 25 %
Power consumption	max. 20 W

General data

Display	5.7 " QVGA (320 x 240 characters) black/white LC-display, illuminated background
Keyboard	8 softkeys and 32 function keys
Housing	housing for switch panel plug-in
Panel frame	205 x 220 mm (w x h)
Insertion depth	136 mm with plug board
Panel cutout	191 x 202 mm
Protection	IP 65 (front side)
Weight	approx. 1.95 kg

Operating conditions

Mounting position	horizontal \pm 45°
Ambient temperature	0 to 50°C (depending on mounting)
Humidity when operating	10 % to 90 % (not condensating)
Storage temperature	-20 to 60°C
Humidity at storage	5 % to 95 % (not condensating)

Inputs and outputs of the basic device

Digital inputs	10; 4 of these are counter inputs (one channel)
Input voltage	24 V \pm 25 %
Input current at 24 V	approx. 4 mA
Digital outputs	9; 1 of these is a relay contact
Switching voltage	24 V \pm 25 %
Output current	max. 0.4 A

Additional moduls

L.0090208203	Analogue input module	1 x \pm 10 V or 0–20 mA (\pm 20 mA possible) potentiometer operating, 12 bit resolution
L.0090208204	Analogue input module	4 x \pm 10 V, 12 bit resolution
L.0090209210	Analogue input module	4 x 0–20 mA
L.0090208205	Analogue output module	2 x \pm 10 V or 0–20 mA (4–20 mA possible) 12 bit resolution
L.0090208206	Digital input module	10 digital inputs 24 VDC
L.0090208208	Digital input module	10 digital inputs, thereof 4 inputs for volume counters (one channel)
L.0090208207	Digital output module	8 digital outputs 24 VDC / 0.5 A
L.0090208217	Temp.-input module	2 x PT 100 3-line from -200°C to +850°C
L.0090208213	RS 232-module	interface RS 232
L.0090208228	RS 485-module	interface RS 485

Dimensions ASR 20

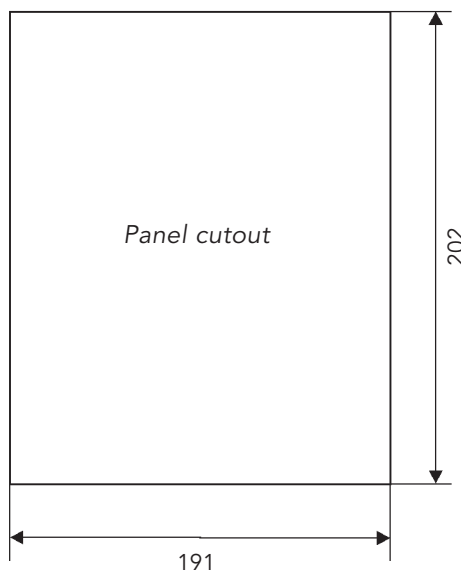
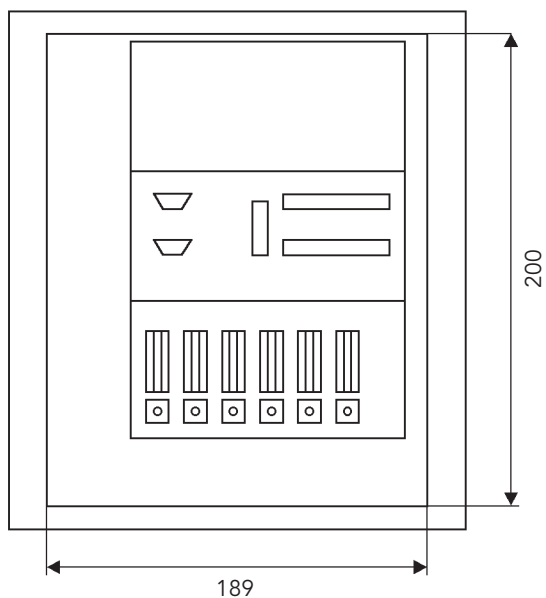
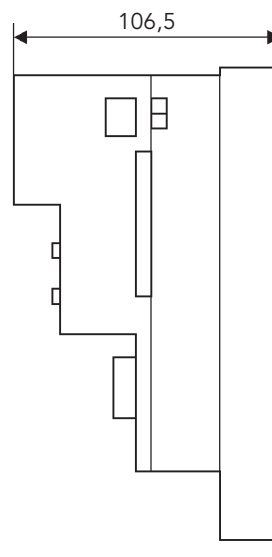
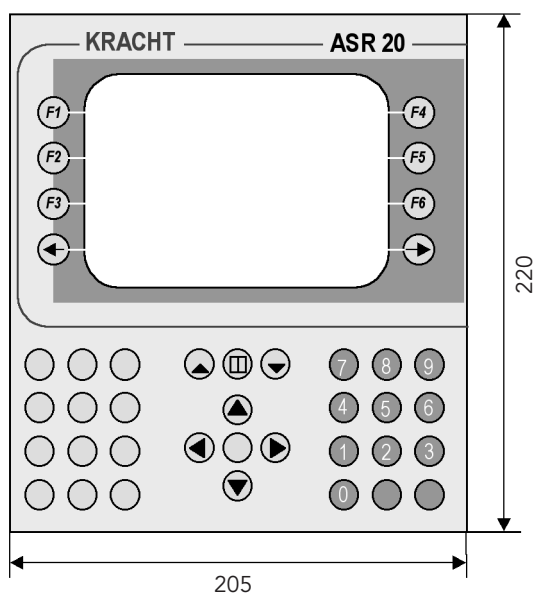

Dimensions in mm

Product Portfolio

Transfer Pumps

Transfer pumps for lubricating oil supply equipment, low pressure filling and feed systems, dosing and mixing systems.

Mobile Hydraulics

Single and multistage high pressure gear pumps, hydraulic motors and valves for construction machinery, vehicle-mounted machines.

Flow Measurement

Gear and turbine flow meters and electronics for volume and flow metering technology in hydraulics, processing and laquering technology.

Industrial Hydraulics / Test Bench Construction

Cetop directional control and proportional valves, hydraulic cylinders, pressure, quantity and stop valves for pipe and slab construction, hydraulic accessories for industrial hydraulics (mobile and stationary use).

Technology Test benches / Fluid Test benches.



Electronic/GB/04.09

KRACHT