

ELRO®

Peristaltic Pumps Series IP, XP and M300

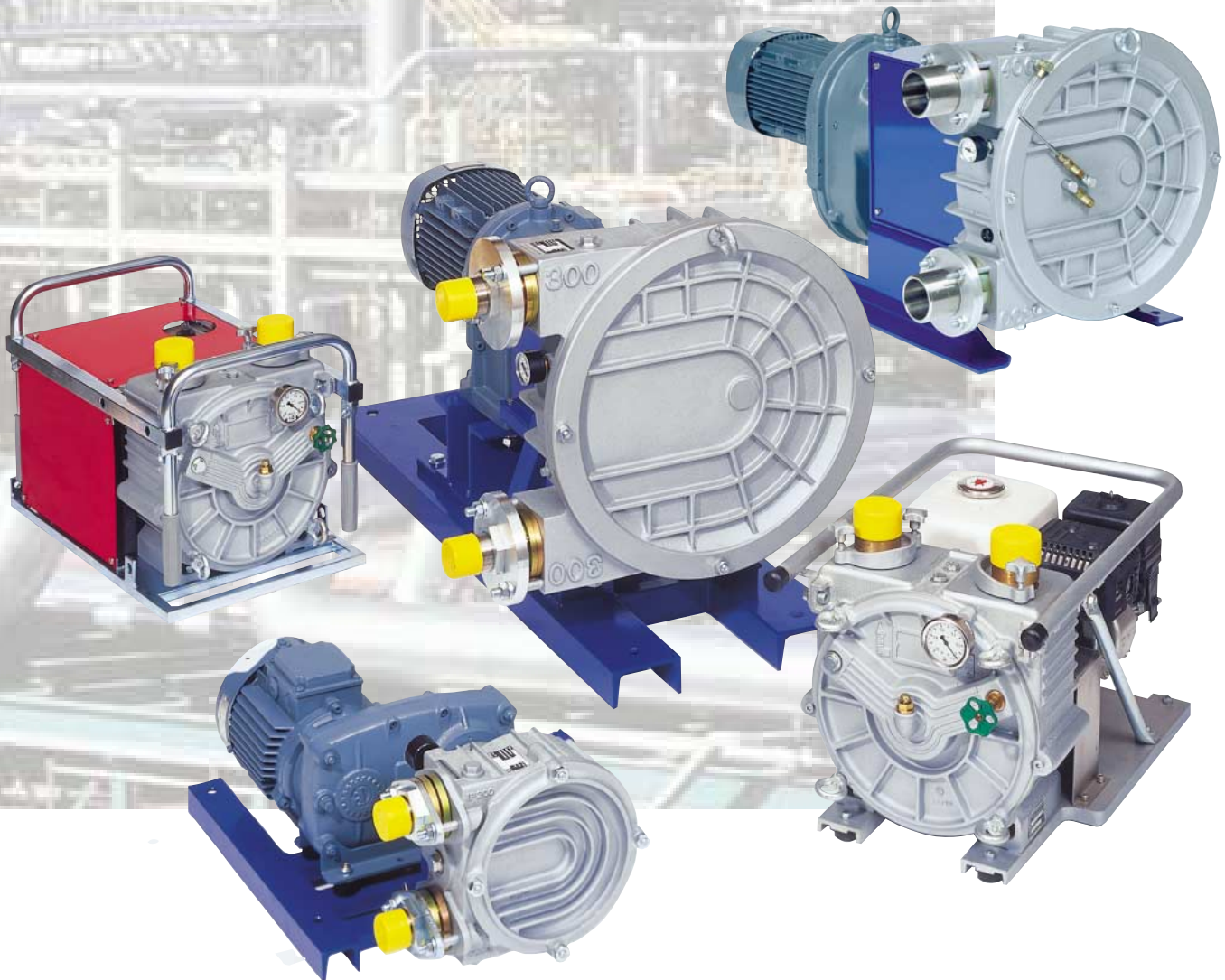

CRANE®

ELRO Peristaltic Pumps

Innovative Technology with Tradition

For over 15 years ELRO Peristaltic Pumps in form of mobile and stationary units have established themselves in the positive displacement pump market as indispensable products for industry.

Day in and day out these pumps demonstrate their reliability and efficiency under the most demanding operational conditions.

Over decades the range of peristaltic pumps has been completed by intensive research, development and the use of new materials. The product range includes the widest material selection for pumping hoses offered by any manufacturer of peristaltic pumps.

The quality demands of customers as well as ease of operation and maintenance are uppermost in the manufacture of these products.

The latest production methods, inspection and testing systems for quality assurance and documented production sequences in compliance with DIN EN ISO 9001 are the basis for constantly outstanding quality of the peristaltic pumps.

With this wide product range ELRO pumps are able to meet most customer requirements, even in extremely difficult pumping processes.

Traditional values in combination with long experience and the available pump/application know-how enables customer and market specific solutions in agreed timescales.

By using the latest technologies, modern manufacturing methods and reliable service the range of ELRO Peristaltic Pumps will continue to maintain its first class position with the users in the future.

Benefits at a glance:

- ideal for abrasive, viscose and shear sensitive media
- gentle pumping of liquid or viscous products
- constant volume capacity due to vacuum support
- dry running resistant
- integrated early warning system
- pumping of media with entrained solids
- unobstructed fluid flow – easy cleaning
- free of dynamic and pressure loaded seals
- portable units Series M300
- infinite regulation of capacity
- high pumping pressures of max. 13 bar / 188 psi for Series IP and XP
- dry self-priming up to max. 9.5 m / 31 feet lift
- easy operation and servicing, only one wear item
- also suitable for explosive environments (Ex-version)



Possible installations

ELRO peristaltic pumps with accessories can be used for many applications and are not restricted to a specific installation location. Fixed installation directly into the process flow is possible, as is the use as mobile or portable unit that can be transported to different applications. The standard version of the pump set-up is the combination: ports on left-hand side (suction side top – pressure side bottom, red).

Of course, the IP series peristaltic pumps may be adapted to existing installations by modification of the port configuration. This only requires the relocation of the stainless steel pipe connections on the suction and discharge side of the vacuum system to suit the desired condition. This can be done without additional machining. Products of series XP are designed with feed and return flow as standard.



Ports left hand side

Ports right hand side

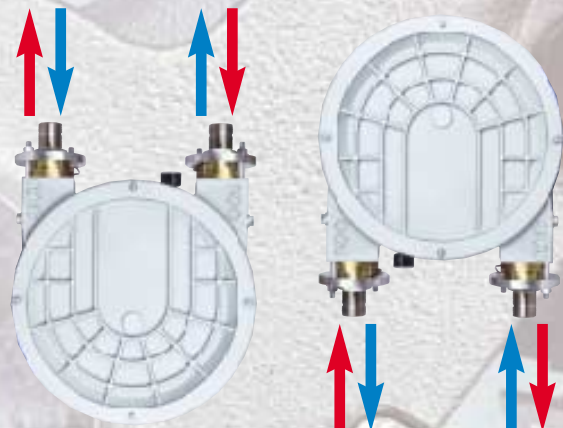

Ports on top

Ports on bottom

Flexible, Modular System

ELRO Peristaltic Pumps, Series IP and XP

Ports on suction and discharge side,
Series IP - male thread
Series XP - DIN or ANSI flange
Suction side left-hand top (standard)
Suction side left-hand bottom
Suction side right-hand top
Suction side right-hand bottom

Paint finish
Pump housing
Silver (standard)
Acid proof paint
Customer-specific
according to RAL

Lubricant filling
Silicon oil
Glycerine

Material
Stainless steel BSP
Stainless steel NPT
Stainless steel RJT
Polypropylene BSP
Polypropylene NPT
PVDF BSP
PVDF NPT

Early warning system
(only for series IP)
Vacuum switch
Conductivity measurement

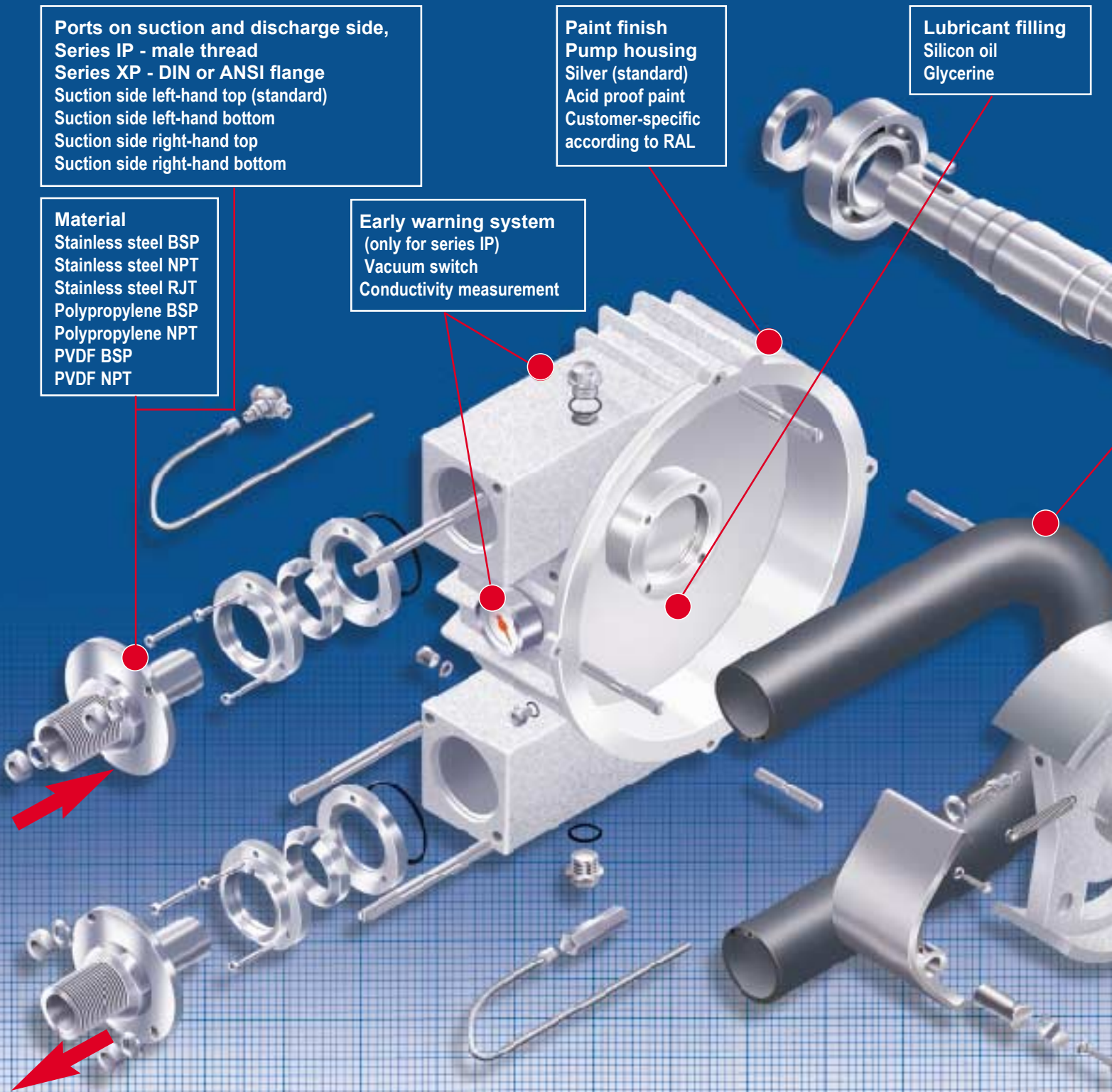

Operation of Series IP and XP

Hose materials	
Natural rubber (NR)	- IP / XP
Natural rubber (NF) FDA	- IP
Nitrile (NBR)	- IP / XP
Nitrile (NBR/E) electrically conductive	- IP
Hyalone (CSM)	- IP / XP
Butyl (IIR)	- IP
EPDM (EPDM)	- IP
Natural rubber (full fabric)	- IP

Pressure ratings / rotor	
0 - 2 bar	/ 0 - 29 psi
2 - 4 bar	/ 29 - 58 psi
4 - 6 bar	/ 58 - 87 psi
6 - 8 bar	/ 87 - 116 bar
8 - 10 bar	/ 116 - 145 psi
10 - 13 bar	/ 145 - 188 psi

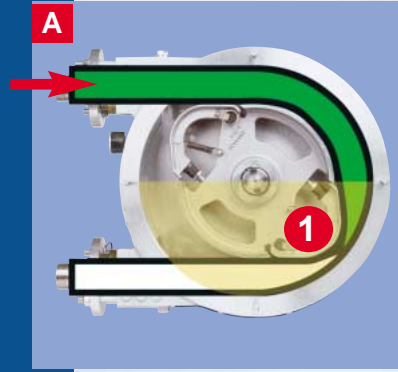

A The rotor rotates within the pump housing filled with lubricant and compresses the pumping hose with the sliding shoe (1). This process generates a hermetic separation between suction and discharge side.

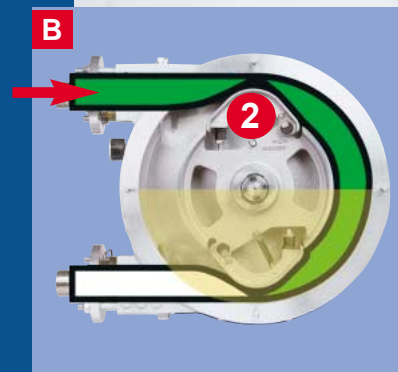

B Once the second sliding shoe (2) compresses the hose, a completely enclosed pumping chamber is formed. This volume corresponds exactly to half the pump capacity per rotation. A vacuum is also generated inside the pump housing, supporting the elasticity of the hose allowing restoration to its original full cross-section.

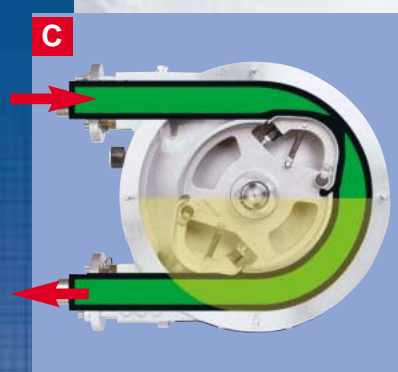

C The rotation of the rotor forces the pumped medium inside the hose towards the outlet port on the discharge side. During each opening of the hose a vacuum is created on the suction side ensuring constant suction. It also takes place when the hose is empty giving high suction conditions.

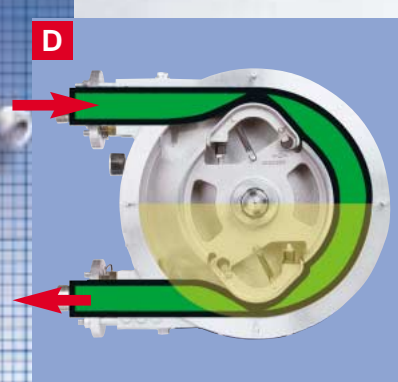

D With each rotation the pumping chamber is reformed and the suction capability is renewed.

Compact, mobile, adaptable

ELRO Peristaltic Pumps Series M300

Hose material

Natural rubber (NR)
Nitrile (NBR)
Butyl (IIR)
Polyurethane (PUR)
Hypalon (CSM) electr. conductive

Camlock connections

Aluminum
Polypropylene
Stainless steel
Bronze

Lubricant filling

Silicon oil
Glycerine

Pump cover

For suction side right-hand (standard)
For reversible operation (option)

Support
CR

Separator
PUR

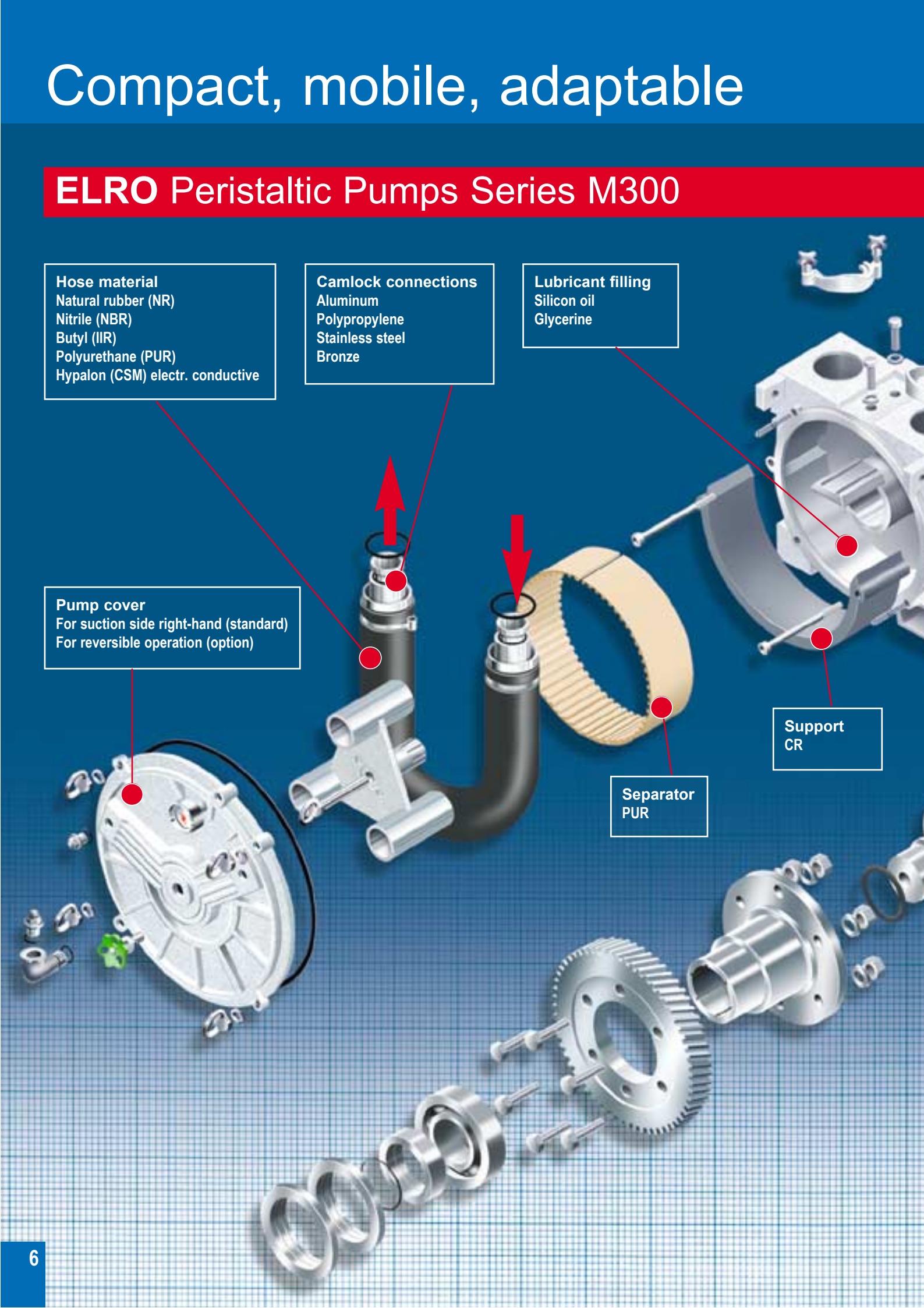

Operation of Series M300

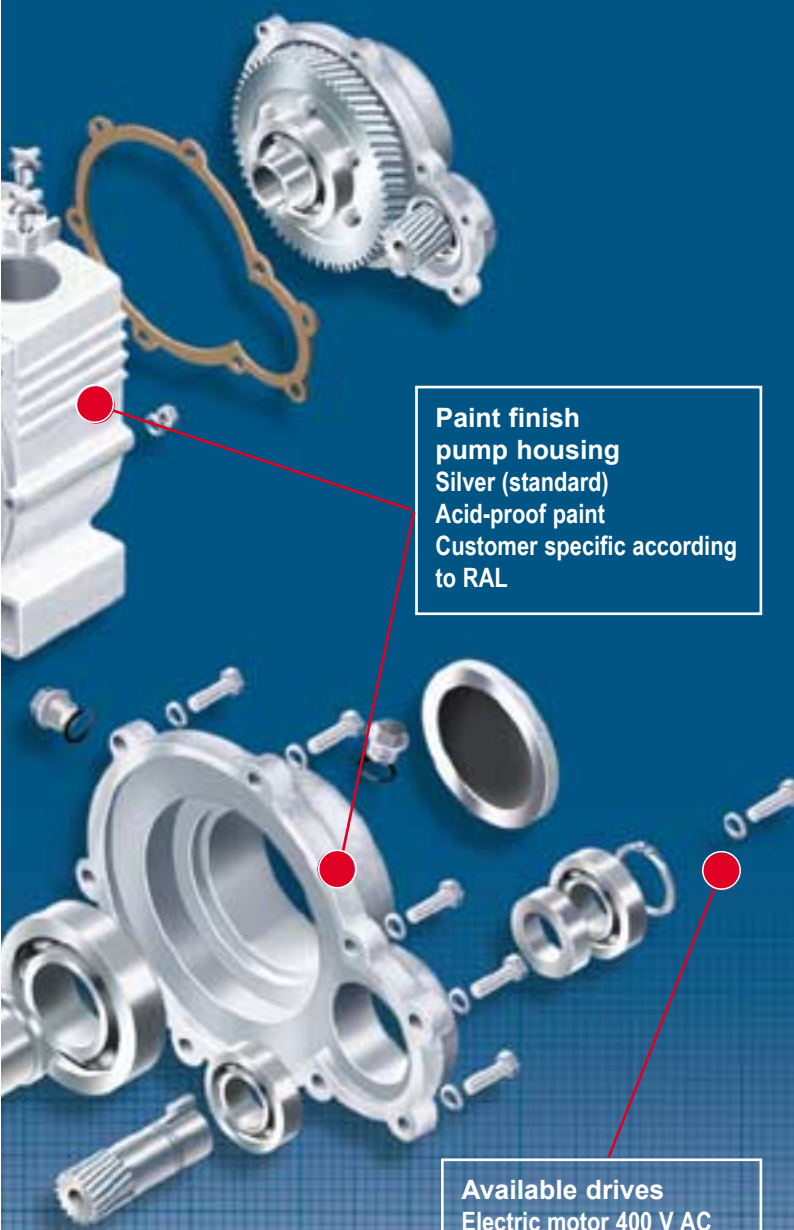

Paint finish
 pump housing
 Silver (standard)
 Acid-proof paint
 Customer specific according
 to RAL

Available drives
 Electric motor 400 V AC
 Electric motor 230 V AC
 Electric motor Ex-version
 Petrol engine
 Diesel engine
 Hydraulic motor
 Pneumatic motor
 Water turbine

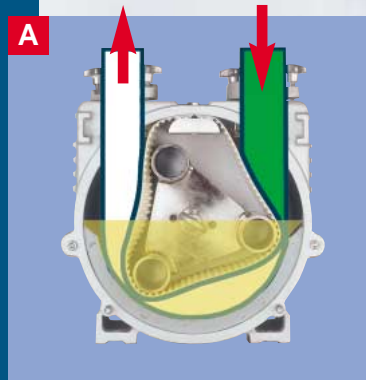

A The rotor turns inside the tightly fixed separator. Which is held in the pump housing filled with lubricant. The separator divides the housing into two completely enclosed areas. This means during compression of the pumping hose the suction and discharge sides are hermetically separated.

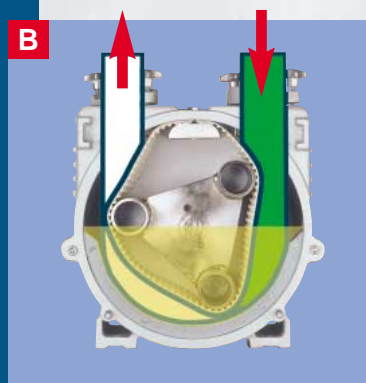

B Air from the suction side is pumped over the separator by the turning of the rotor and exhausted outside the pump. This forms a vacuum inside the pump chamber relative to the suction lift, which supports the elasticity of the hose during restoration to its original full cross-section.

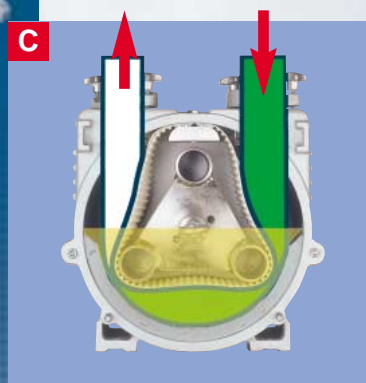

C Once the second sliding shoe compresses the hose, a pumping chamber is formed. This volume corresponds exactly to one-third of the pump capacity per rotation. The rotation of the rotor presses the medium inside the hose towards the outlet on the discharge side. During each opening of the hose a vacuum is created on the suction side ensuring constant suction. It also takes place when the hose is empty giving high suction lift conditions.

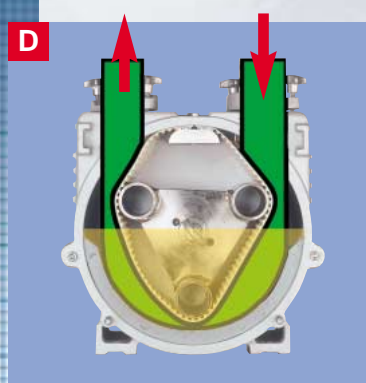

D With each rotation the pumping chamber is reformed and the suction capability is renewed.

ELRO Peristaltic Pumps

Selection, Pump Capacity

For the selection of the mobile ELRO Peristaltic pumps series M300, the following factors are to be considered:

- pumping medium
- pumping capacity
- suction and discharge conditions
- operation time per day
- location of use
- accessories with suitable couplings

The most essential points for low wear operation of stationary peristaltic pumps series IP and XP are apparent by the following dependencies:

pumping media \Leftrightarrow speed

media temp. \Leftrightarrow hose compression

discharge pressure \Leftrightarrow Consider larger diameter discharge lines

operation time per day \Leftrightarrow continuous intermittent short time

After fixing the operation point, depending on the above parameters, an exact specification of the pump can be made using the individual data sheets. Using the selection diagram, adjustments may be necessary after consideration of the factors "Operation time/day and media temperature".

At a media temperature $>40^{\circ}\text{C}/140^{\circ}\text{F}$, hose life is shortened and a speed reduction should be considered.

- Short-time operation (max. 4 hours)
- Intermittent operation (max. 12 hours)
- Continuous operation (24 hours)

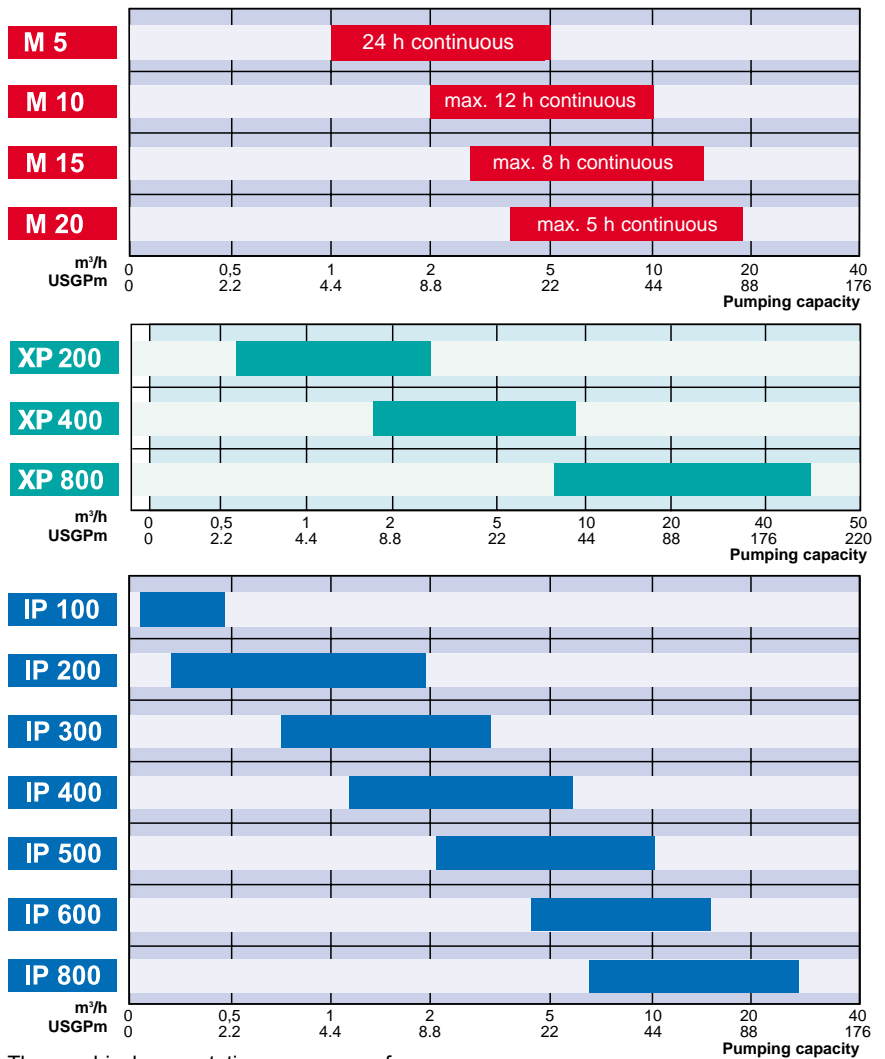

The graphical presentation serves as reference. Exact details can be obtained from the respective data sheets.

Selection diagrams for Series IP und XP

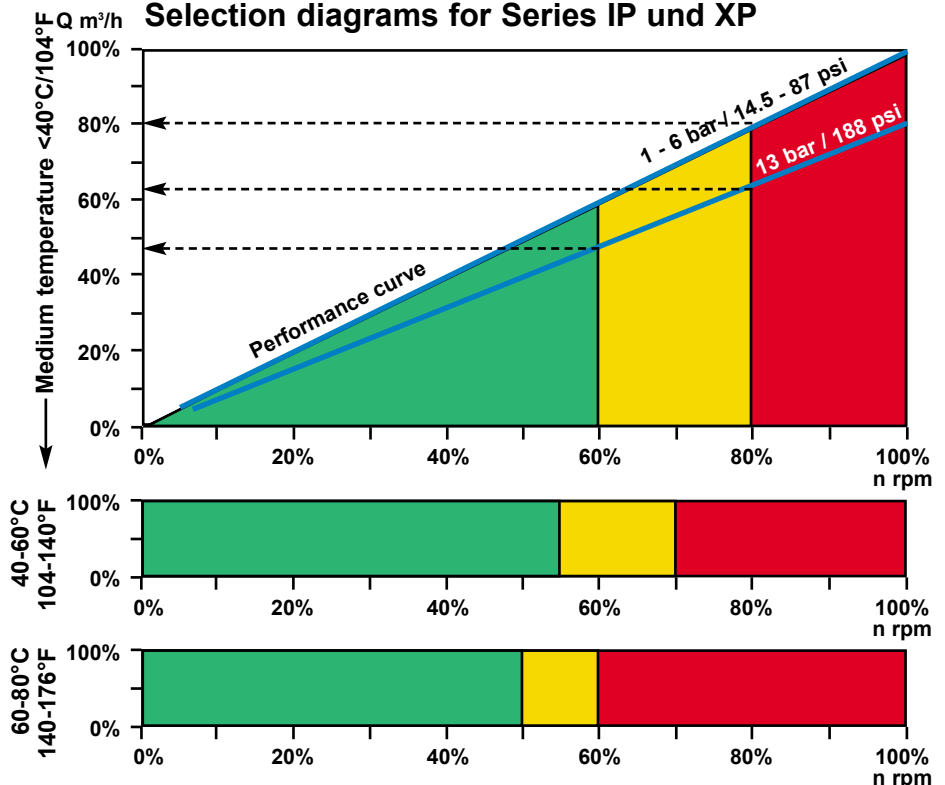

Elastomers

Natural rubber (NR)

IP M300 XP

Natural rubber (FDA)

IP

Composition: natural substance, high-polymer isoprenes

Properties: tension-resistant, elastic, cold-resistant, approved for food applications
Operative range: for abrasive media, diluted acids and alkalis

Temperature range: -20°C - +80°C
-4°F - 176°F

Nitrile rubber (NBR)

IP M300 XP

Composition: mixed polymeride from butadiene and acryl nitrile

Properties: wear-resistant, grease and oil resistant

Operative range: for oily and greasy media, alcohols

Temperature range: -10°C - +80°C
+14°F - 176°F

Butyl rubber (IIR)

IP M300

Composition: mixed polymeride from isobutadiene and isoprenes

Properties: heat resistant and non-aging, gas-tight

Operative range: for organic and inorganic acids and alkalis, ketones and hot water

Temperature range: -25°C - +80°C
-13°F - 176°F

Hypalon (CSM)

IP M300 XP

Composition: elastomer formed through polymerisation of chlorosulfonated ethyls

Properties: chemical resistant, wear resistant and electric conductive (only M300)

Operative range: for acids and alkalis, colours

Temperature range: -20°C - +80°C
-4°F - 176°F

EPDM (EPDM)

IP

Composition: EPDM rubber through co-polymerisation of ethyl, propylene and diene

Properties: chemical resistant, good insulating properties and outside applications

Operative range: for acids and alkalis, hot water

Temperature range: -30°C - +80°C
-22°F - 176°F



Polyurethane (PUR) M300

Composition: elastomer formed through polyaddition of isocyanate and alcohol

Properties: hard wear and abrasion proof, oil resistant

Operative range: for abrasive and oily media

Temperature range: -20°C - +80°C
-4°F - 176°F

For further details see our separate compatability guide

For special applications, special full fabric hoses are available for the series IP.

ELRO peristaltic pumps can be equipped with a suitable pumping hose for almost any application.

The great variety of different hose materials results from intensive research and long-term tests.

Hose manufacturing

All ELRO pumping hoses are precision ground after the production process. This additional process ensures an uniform surface and a constant outside diameter compared with conventional hoses.

It prolongs hose life and in addition, a consistent pump capacity is achieved for all pumps.

Housing material

The pump housings of the ELRO peristaltic pumps are cast from aluminium. This process which is more complicated than steel casting or welded designs is used for the following reasons:

- better heat dissipation
- integration of cooling ribs
- air tight housing
- reduction of wall thickness
- compact construction
- wear resistant
- low weight



ELRO Peristaltic Pumps

Series IP



The IP series of ELRO peristaltic pumps distinguish themselves through a gentle transport of liquid or viscous media. Also capable of handling abrasive, shear-sensitive products with long fibres and solids. Over the years they have become an integral part in the pump pool of many operators.

The 13 bar / 188 psi pump pressures of the standard versions make ELRO peristaltic pumps suitable for replacing other pump technologies. The seven pump sizes, various hose materials including food approved versions and the different port options allow individual adaptation to each application. This variety is further expanded by the frame and motor variants.

Type	Pump capacity max.	Displacement per revolution	Discharge pressure max.	Inner hose diameter	Speed max.	Drive output min/max	Weight without drive
	m ³ /h U.S.gal./min	l/rev U.S.gal./rev	bar / psi	mm / inch	rpm	kW / h.p.	kg / lb
IP 100 (1")	0,6 2,64	0,07 0.018	10 150	15 0.59	140	0,37 – 1,1 0.50 – 1.5	12 26
IP 200 (1 1/4")	1,9 8,36	0,22 0.058	13 190	30 1.18	140	0,55 – 1,5 0.75 – 2.0	16 35
IP 300 (1 1/2")	3,1 13,6	0,85 0.224	13 190	35 1.38	70	1,10 – 4,0 1.50 – 5.5	48 106
IP 400 (2")	6,0 26,4	1,65 0.436	13 190	50 1.96	60	1,50 – 5,5 2.0 – 7.5	51 112
IP 500 (2")	10,5 46,2	2,9 0.766	13 190	52 2.0	60	2,2 – 7,5 3.0 – 10	110 242
IP 600 (2 1/2")	16,0 70,4	4,45 1.175	13 190	60 2.4	60	3,0 – 11 4.0 – 15	123 271
IP 800 (3")	28,0 123,2	7,8 2.06	13 190	70 2.76	60	5,5 – 18,5 7.5 – 25	248 546

ELRO peristaltic pumps are equipped as a standard with a patented vacuum system. It leads to many economic and technical advantages such as:

- very good suction properties up to 9.5 m / 31 feet lift (no additional suction equipment required)
- constant pump capacity during the entire hose life
- enables the hose to reform to its full cross section
- low reduction in capacity when handling very viscous media
- use as early warning system for a just in time hose exchange

Dimensions
mm / inches

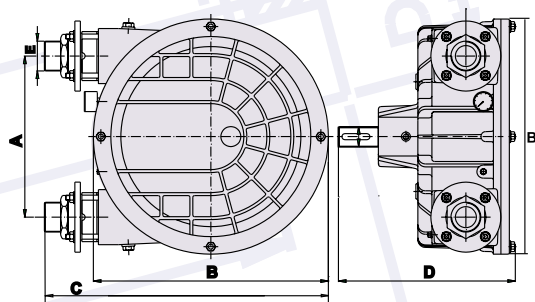

Type	IP 100	IP 200	IP 300	IP 400	IP 500	IP 600	IP 800
	(1")	(1 1/4")	(1 1/2")	(2")	(2")	(2 1/2")	(3")
A	152/5.98	140/5.51	336/13.23	320/12.60	516/20.31	510/20.08	692/27.24
B	242/9.53	242/9.53	470/18.50	470/18.50	680/26.77	680/26.77	890/35.04
C	316/12.44	316/12.44	585/23.03	570/22.40	840/33.07	800/31.50	1020/40.16
D	290/11.42	290/11.42	380/14.96	355/13.98	480/18.90	500/19.68	680/26.77

Main application:

- Chemical industry
- Ceramic and porcelain industry
- Food and beverage industry
- Breweries
- Cosmetic and pharmaceutical industry
- Power stations
- Colour and painting industry
- Waste and disposal industry



The patented early warning system (see illustration right **2**, **3**) works as follows: Each hose is provided with a small additional channel through which the air in the upper section of the pumping chamber is evacuated from the pump housing. Therefore, a vacuum is formed in the sealed aluminium housing. In the case of damage or normal wear of the hose, the vacuum will drop.

The early warning can be seen through the installed vacuum gauge. An acoustic or optical signal can be activated by using the vacuum switch **1**.

By this, the hose condition is monitored for optimum service planning.

Downtimes through normal wear can be predicted.

Applications



Waste disposal industry

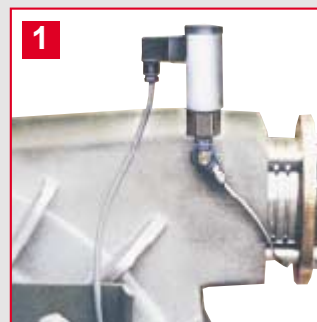

Early warning system switch



Chemical industry



Early warning system suction side



Early warning system discharge side

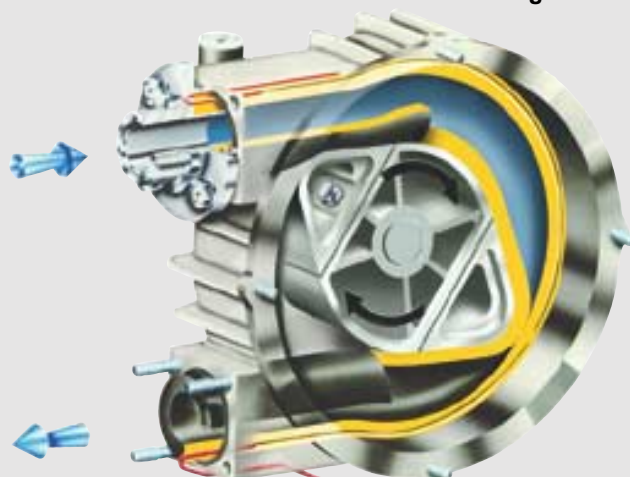

ELRO Peristaltic Pumps

Series XP

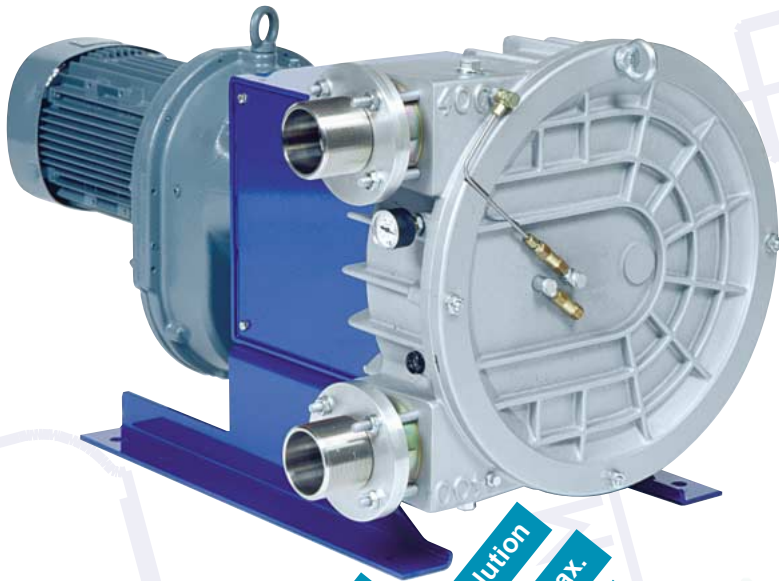

The newly developed ELRO peristaltic pumps of series XP are characterized by a high pumping capacity at low rotary speed. The amply dimensioned cross-section of the hose enables the transport of fluids with high solids content.

Series XP is equipped with the newly developed vacuum system integrated in the pump housing as standard. In connection with the specially manufactured thin-walled peristaltic hose these pumps are characterized by excellent suction properties and long hose lives.

- Type
- Pump capacity max.
- Displacement per revolution
- Discharge pressure max.
- Inner hose diameter
- Speed max.
- Drive output min/max
- Weight without drive

Type	m ³ /h U.S.gal./min	l/rev U.S.gal./rev	bar / psi	mm / inch	rpm	kW / h.p.	kg / lb
XP 200	3,2	0,38	10	35	140	0,75 - 1,5	18
	14	0.10	150	1.38		1.0 - 2.0	40
XP 400	9,6	2,67	13	63	60	1,5 - 5,5	53
	42	0.70	195	2.48		2.0 - 7.5	117
XP 800	46	12,8	10	91	60	5,5 - 18,5	254
	202	3.38	150	3.59		7.5 - 25	560

Dimensions (mm)

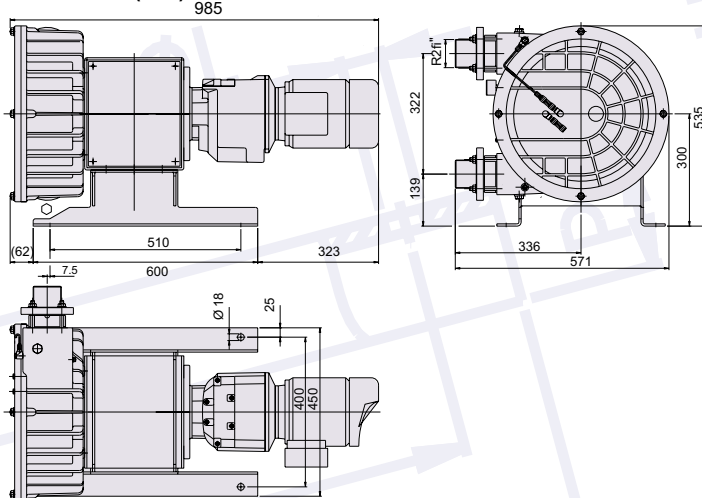

Type	XP 200	XP 400	XP 800
E	(1 1/2")	(2 1/2")	(4")
A [mm/inch]	140 / 5.51	320 / 12.6	692 / 27.2
B [mm/inch]	242 / 9.53	470 / 18.5	890 / 35.0
C [mm/inch]	316 / 12.4	570 / 22.4	1020 / 40.2
D [mm/inch]	290 / 11.4	355 / 14.0	680 / 26.8

This new design offers numerous economical and technical benefits, e.g.

- high pumping capacity at low rotary speed
- approved compact design
- safe to run dry
- integrated vacuum system
- dry self-priming max. 9.5 m
- due to the vacuum support transfer of highly viscous products
- discharge pressure max. 13 bar
- due to the 40 mm hose diameter ideal for long fibrous materials and solids
- forward and reverse pumping possible by standard
- the vacuum support ensures a constant pump capacity over the entire lifetime
- various materials for hoses and connections available

Main application:

- Chemical industry
- Ceramic and porcelain industry
- Construction industry
- Power plants
- Colour and painting industry
- Waste and disposal industry
- Galvanic industry
- Waste water plants
- Slaughter-houses

Applications



Chemical industry

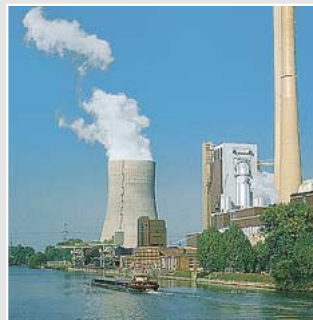

Power plants



Chemical industry

The integrated vacuum system (see illustrations **1**, **2**, **3** right) works as follows: The rotor rotates inside the lubricant filled pump housing and squeezes the pumping hose with the sliding blocks. At the same time the rotor mounted sliding blocks **3** compress diaphragm **1**, which is integrated in the pump cover. This pumping process discharges the air from inside the housing through the exhaust in cover **2** to the outside.

ELRO Peristaltic Pumps of series XP can also be equipped with a vast variety of accessories.

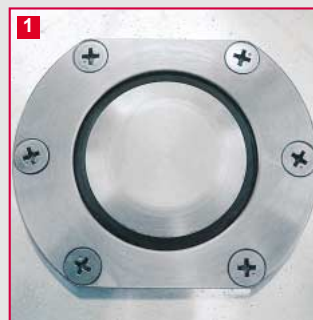

Rotor/combined vacuum system

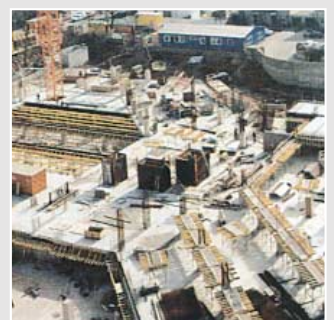

Construction industry

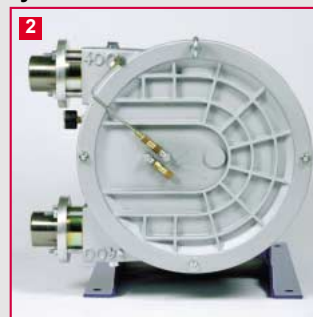

Vacuum system



Vacuum system, inside view

ELRO Peristaltic Pumps

Series IP and XP

The IP and XP series of ELRO peristaltic pumps are available with a variety of accessories for each application.

- 1 Early warning system EWS (only available for series IP), complete evaluation and signalling unit incl. pump head mounted sensors to measure temperature, overpressure, conductivity and vacuum.
- 2 Compensators in steel, stainless steel with matched elastomer materials
- 3 Flanges in steel, stainless steel and plastic according to different standards
- 4 Quick action couplings and fittings, e.g. coupling in stainless steel, brass and aluminium, DIN and triclamps
- 5 Suction/discharge hoses are available with nominal sizes between 1" and 4" and equipped with suitable coupling systems, completely pressure-tested. Standard spiral hoses with plastic and steel reinforcement, chemical hoses or suction/discharge hoses approved for food applications.
- 6 Pulsation dampers made of different housing materials: lacquered steel, polypropylene or stainless steel. Depending on the type of design and size with an inner membrane complete with fittings and pressure gauge.
- 7 Vacuum switch for checking the vacuum in the pump housing. Pressure drop = Alarm.
- 8 Conductivity sensors for the conductivity measurement. If conductivity fluid is mixed with the medium = Alarm.

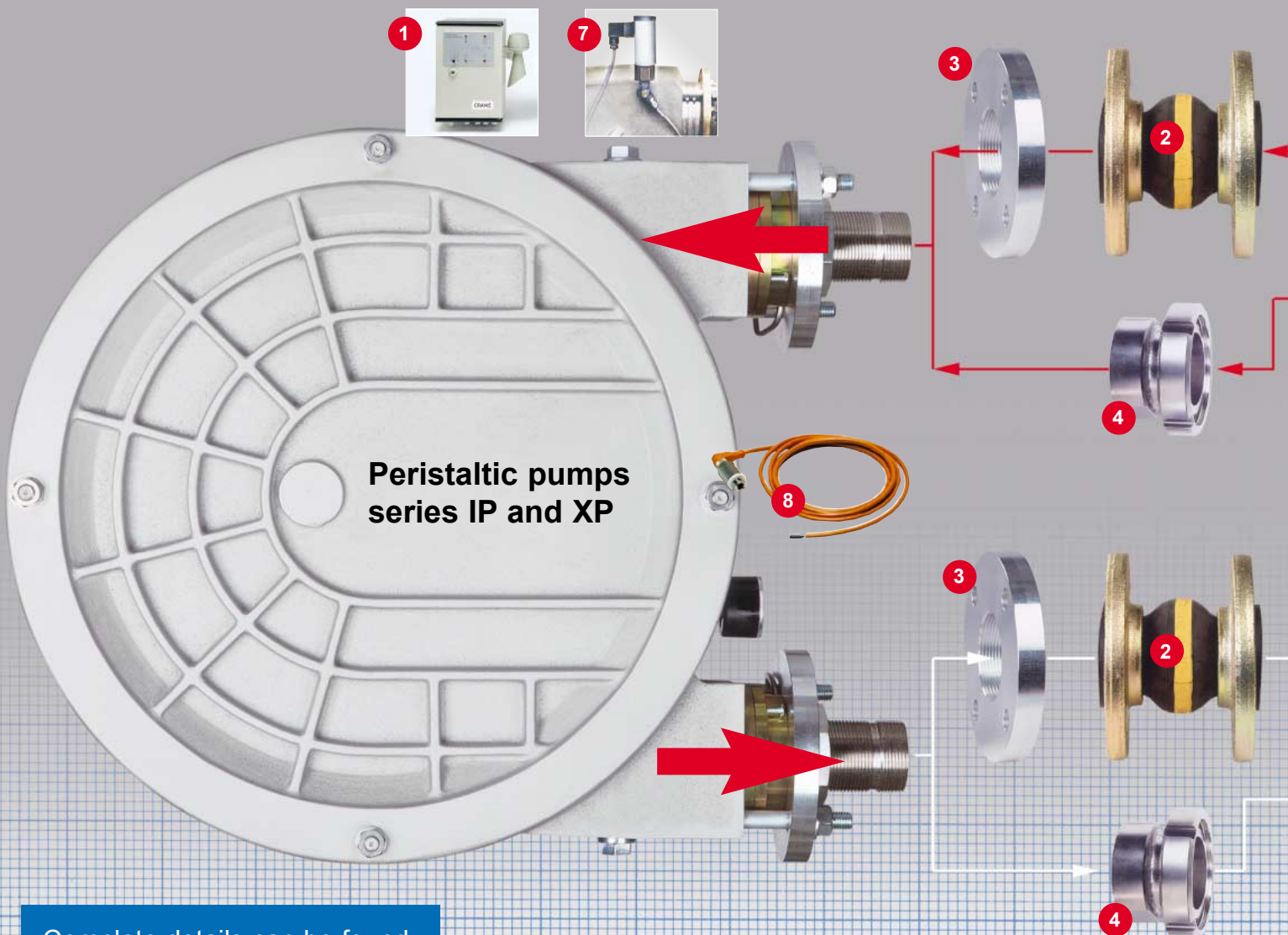

Complete details can be found in the accessories catalogue.

Pump coding IP and XP



Type	Size	Connections	Hose / lubricant	Pump pressure	Paint finish	Connecting position with regard to suction side viewed from front	Base frame
I	10	IP100	E Stainless steel	A 0- 2 bar	A Silver	- left/top (standard)	A steel painted (150-180)
X	20	IP200	NPT	0- 29 psi	B Acid-proof paint	A left/bottom	B steel painted (110-140)
	30	IP300	R Stainless steel	B 2- 4 bar	C Customer-specific	B right/top	C Stainless steel (110-140)
	40	IP400	RJT	29- 58 psi		C right/bottom	D Steel painted movable
	50	IP500	S Stainless steel	C 4- 6 bar		D top/left	E Stainless steel movable
	60	IP600	BSP	58- 87 psi		E top/right	F Steel painted specified
	80	IP800	K Polypropylene BSP	D 6- 8 bar		X left/full fabric coating	G Stainless steel painted
	20	XP200	T Polypropylene	87-116 psi		Y right/full fabric coating	H steel painted (150-180)
	40	XP400	NPT	E 8- 10 bar		Z top/full fabric coating	J steel painted (SF350)
	80	XP800		F 10- 13 bar			
			H CSM + silicon	145-188 psi			
			J IIR + silicon				
			K IIR + silicon				
			N NR + silicon				
			W NR full fabric + silicon				
			Y NR full fabric + glycerine				

Suction Side Accessories

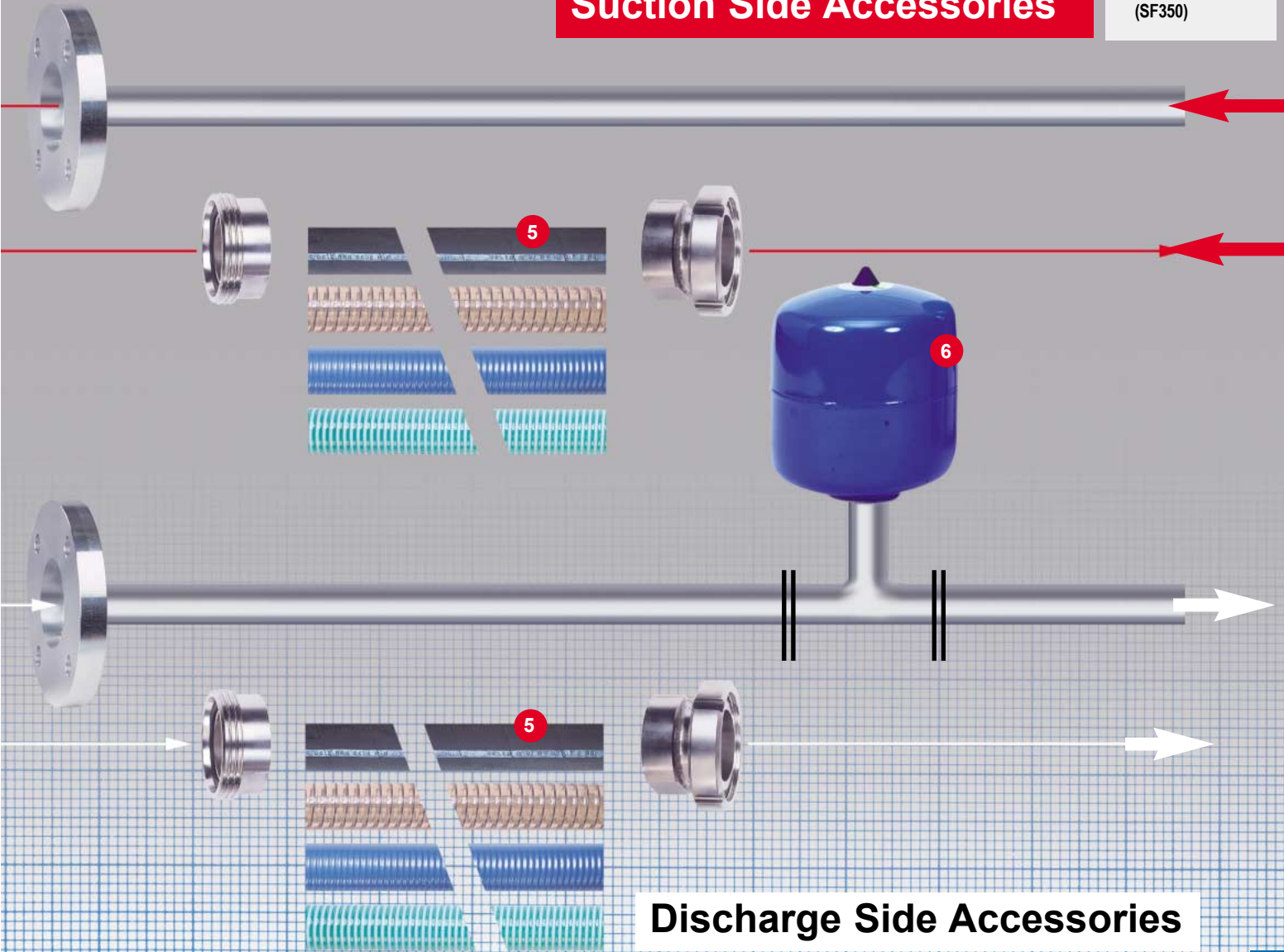

Discharge Side Accessories

ELRO Peristaltic Pumps

Series M300



ELRO M300 series Peristaltic Pumps were designed for safe, quick and mobile applications in the most varied industrial operating conditions. Over many years this unique, patented pump system has been and is successfully used world-wide for more and more new applications.

The basic idea during the development of the mobile peristaltic pumps was to integrate the advantages of standard peristaltic pumps and to achieve a compact, portable and flexible design. This idea was realised through a special, patented concept in the pump housing design.

Type/Drive	Weight
M 5 E(X) – M 20 E(X) Electric motor 230-400 V + EX	55-65 kg 121-143 lb
M 15 / 7,5 E(X) – M 20 / 10 E(X) Two-stage electric motor 400 V + EX	62-65 kg 136-143 lb
M 20 B Petrol engine 4,0 kW / 4000 rpm 5.4 HP	52 kg 115 lb
M 20 D Diesel engine 3,4 kW / 3600 rpm 4.6 HP	75 kg 165 lb
M 20 H Hydraulic drive	55 kg/121 lb
M 20 L Pneumatic motor	58 kg/128 lb
M 20 WT Water turbine	56 kg/123 lb
M 20 FU Electric motor with integrated frequency converter	66 kg/145 lb

It enables the use of thin-walled pumping hoses which are continuously expanded to their full cross-section by the permanent vacuum. Pumping capacities between 4 m³/h and 22 m³/h (17.6 - 97 USGPM) can be achieved.

Examples of application: Emergency pump on ships, sanitary disposal unit for fast trains, loading pump for road tankers, at power stations and sewage plants for sampling and for cleaning tanks and basins, in the chemical industry, for fluid transfer duties.

These pumps prefer a long suction line up to the absolute vacuum whereby suction lengths of more than 50 m (164 feet) are frequently used.

The discharge pressure should not exceed 2 bar (29 psi).

Main Application:

- Environmental technology
- Tank cleaning
- Building industry
- Chemical industry
- Forwarders
- Power stations, disposal technology
- Ships, port facilities and skimmer

Applications



Forwarders



Environmental technology



Disposal technology



Galvanic station



Disposal fast trains

The peristaltic pumps can be equipped with different hose materials depending on applications as well as with couplings on the suction and discharge side in different materials and designs.

The M300 series can be selected with a variety of different motors.

For special applications, the pump is also available in a reversible design. Therefore it is possible to pump in the opposite direction with the same performance features - a decisive criterion when pumping out and pumping over media which are harmful to the environment.

The design of all pumps enables changing of pumping hose and all components within shortest period of time without any additional special tools.

Dimensions (mm)

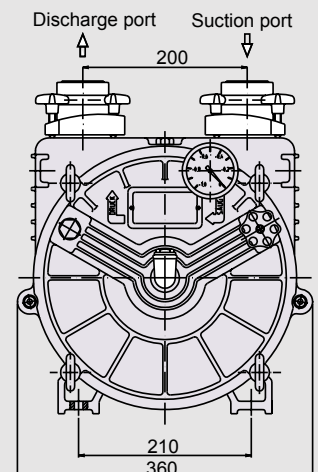
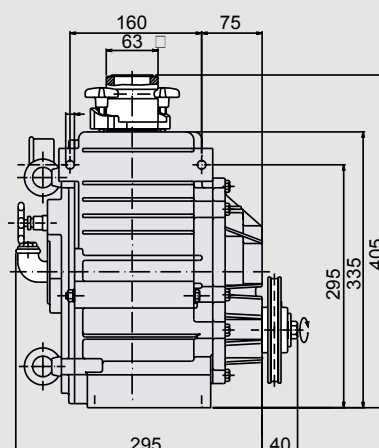

ELRO Peristaltic Pumps

Series M300

ELRO Peristaltic Pumps are available with a variety of accessories suitable for each specific application.

- 1 KL quick release couplings, pipe elbows, Storz couplings made of aluminium, brass or stainless steel, plastic, DIN, tank vehicle couplings made of brass or stainless steel.
- 2 Pulsation dampers made of aluminium and stainless steel with suitable T-piece.
- 3 Suction/discharge hoses are available with nominal size between 1" and 4" and equipped with suitable coupling systems completely pressure-tested.
- 4 70 litre (18.4 USGAL) pre-filter vessel made of steel and stainless steel with filling equipment
- 5 180 litre (47.5 USGAL) transport drum made of stainless steel with filling equipment
- 6 Hose cleaning device and balls in different designs.
- 7 Suction baskets, flat vacuum pick-ups, special suction pipes and residue suction nozzles made of various materials and in different designs.

Discharge Side Accessories

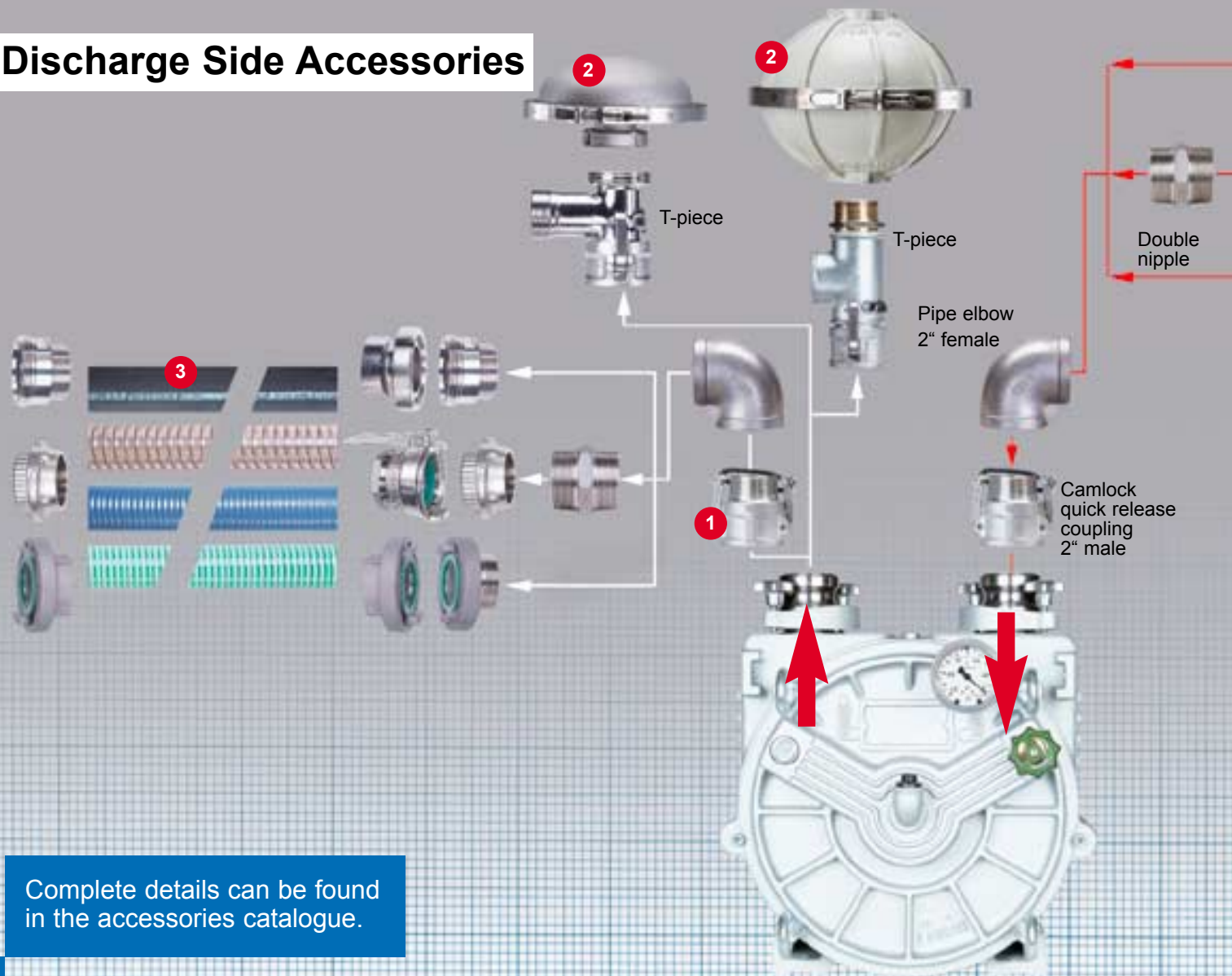

Complete details can be found in the accessories catalogue.

Pump coding

M 05 A B - E B -

Model	Type m³/h USGpm	Connections	Hose / lubricant	Paint finish	Base frame	Motor type	Motor
M	05 5 22	A Aluminium	B NBR+silicon	- Silver	E Fire brigade carrying frame stainless steel	B Petrol	- without
	07 7 31	K Polypropylene	C CSM + silicon	H Acidproof paint	F Fire brigade carrying frame galvanised steel	D Diesel	D EEx d T4
	10 10 44	R Brass	D NBR + glycerine	Z Customer-specific	T Aluminium (Standard)	E Electric	E EEx e T3
	11 10/5 44/22	S Stainless steel	G NR + glycerine		M Vehicle stainless steel	H Hydraulic	F Faryman
	15 15 66		H CSM + glycerine			L Pneumatic motor	H Honda
	17 15/7 66/31		J IIR + silicon			R Reversible	R Reversible
	20 20 88		K IIR + glycerine			W Water turbine	Y Yanmar
	21 20/10 88/44		N NR + silicon				Z Hatz
	OM Without Motor		P PUR + silicon				
			R PUR + glycerine				

Suction Side Accessories

Option

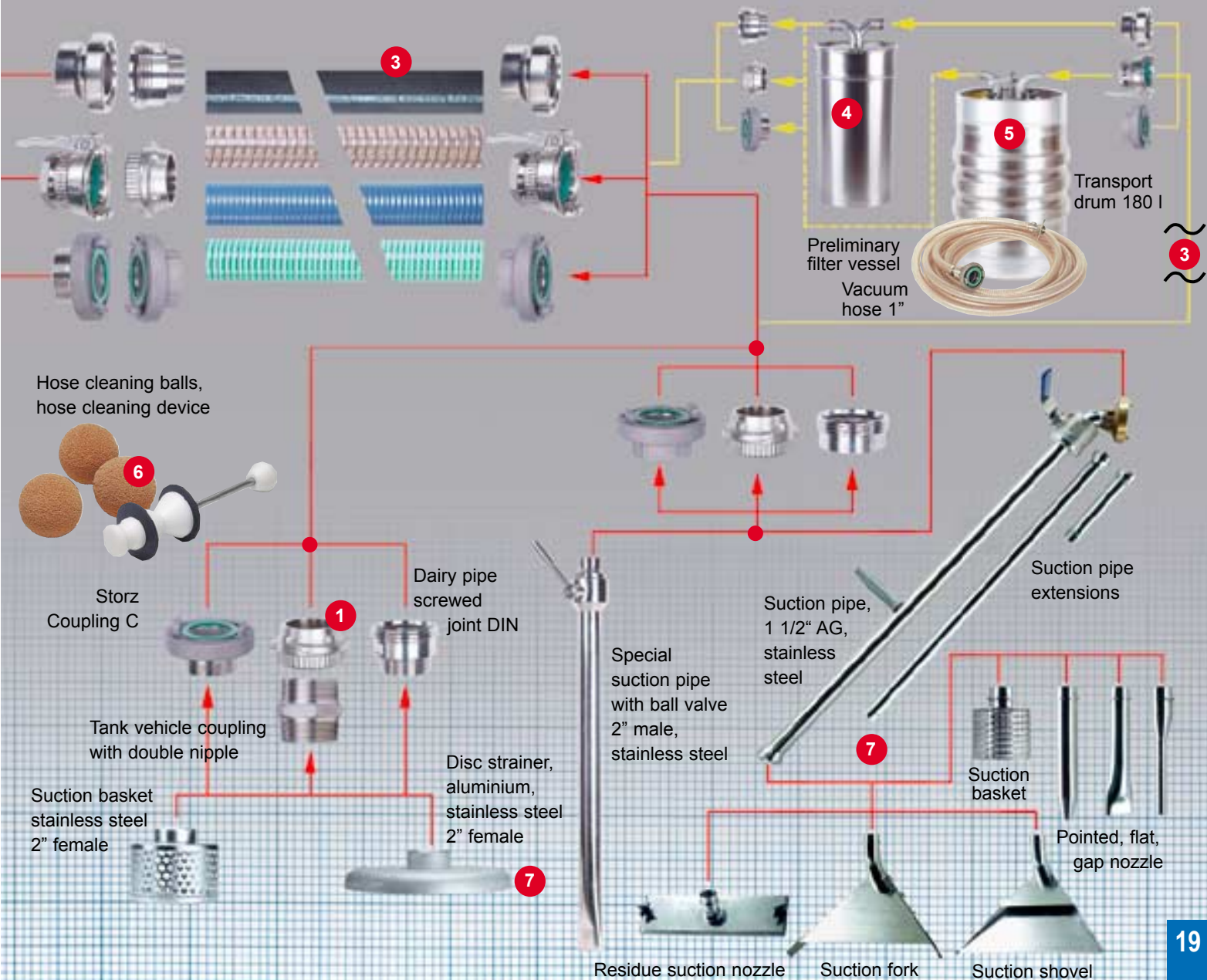

International Organisation:

Crane Process Flow Technologies

Headquarter
7 Doman Road
Camberley
Surrey GU15 3DN
UNITED KINGDOM

Crane Pumps and Systems

420 Third Street
Piqua, OH 45356
USA

Crane Process Flow Technologies BVBA-SPRL

Avenue Franklin 1
1300 Wavre
BELGIUM

Resistoflex (Asia) PTE, Ltd.

No. 16 Gul Link
Singapore 629386
SINGAPORE

Crane Process Flow Technologies GmbH

Heerdter Lohweg 63-71
40549 Düsseldorf
GERMANY

XOMOX Int'l GmbH & Co

Can Corbera - Nave 3c
8192 Barcelona
Spain

Crane Process Flow Technologies GmbH

IZ NÖ Süd, Str. 2/M6
2355 WR Neudorf
AUSTRIA

Crane Process Flow Technologies s.r.l.

Via Pusiano 2
20052 - Monza MI
ITALY

Crane Process Flow Technologies Ltd.

Cwmbran
Grange Road
Gwent NP44 3XX
UNITED KINGDOM

Crane Process Flow Technologies Ltd.

Niti Apartments, Opp. Moreshwar Society
Baner Road
Pune 411 007
INDIA

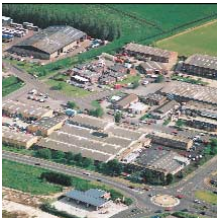

Crane Process Flow Technologies GmbH

P.O.-Box 11 12 40
D-40512 Düsseldorf
Heerdter Lohweg 63-71
D-40549 Düsseldorf
Phone +49 211 5956-0
Fax +49 211 5956-111

