

SFM-100/ MOS-LED

RAPID KINETICS AND SPECTROSCOPY

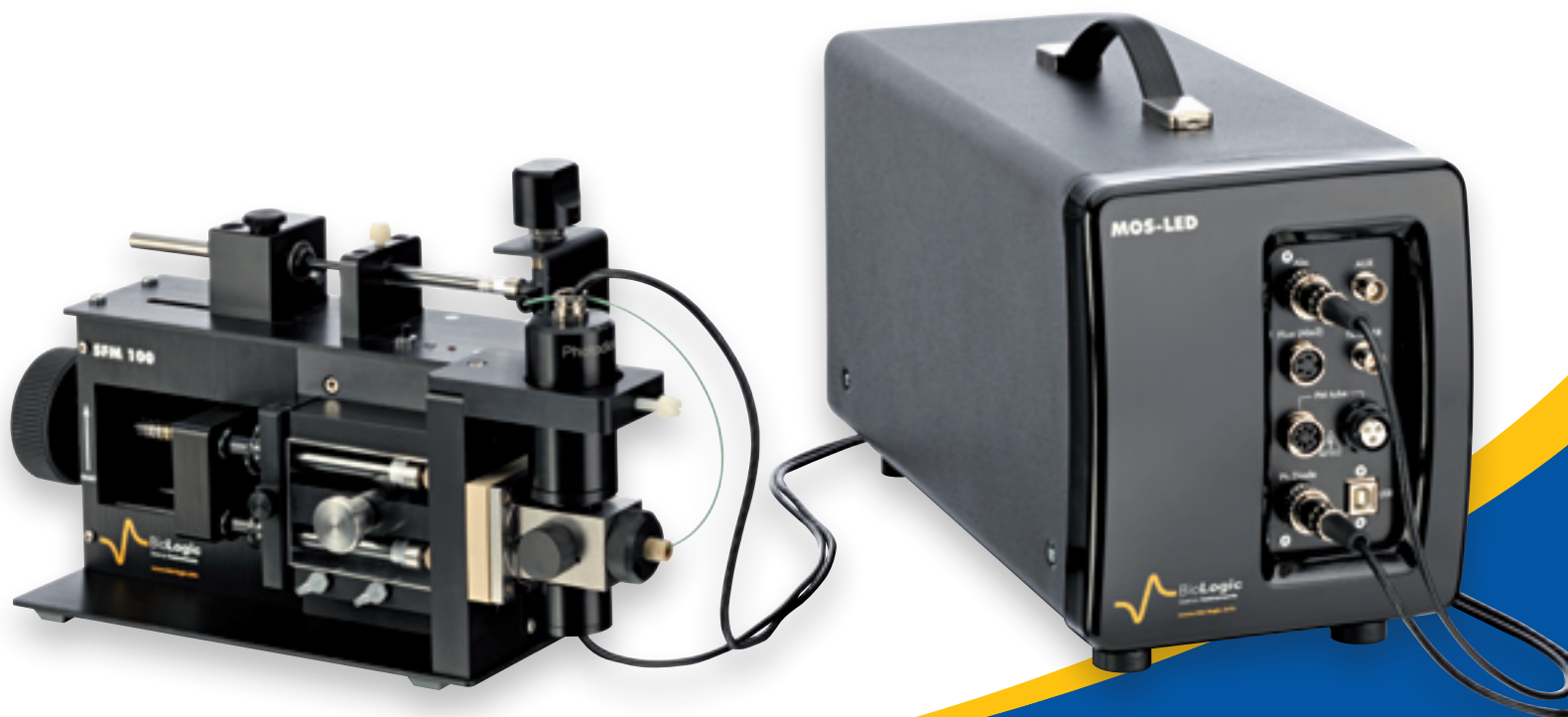

All in one stopped-flow system

- FAST, SIMPLE SINGLE MIX KINETICS
- INTEGRATED ABSORBANCE SPECTROSCOPY
- SPEC-LAB SOFTWARE
- OPTIONAL FLUORESCENCE
- OPTIONAL MOTORIZED DRIVE

Mixing

The **SFM-100/MOS-LED** is ideal for basic rapid kinetics research and teaching applications. Delivering research grade performance in low cost two syringe system with low sample consumption, excellent data acquisition specifications, and a user friendly design, the **SFM-100/MOS-LED** is the perfect system for teaching labs or basic research applications.

Sample consumption as low as 30ul per shot with 20 µl dead volume provides great sample economy. Dead time to 8ms is typical in manual mode, and down to 5 ms with the optional motor drive. In manual mode mixing is done with a drive wheel system that has built in protection against overpressure. A stop syringe is used to trigger acquisition, and sets the shot volume. Mixing is done with our proven Berger-ball mixer, which delivers the best possible turbulent mixing, over the widest range of flow and viscosity conditions.

Detection

The **MOS-LED** is based on **Bio-Logic's** long experience with LED spectrometry. Single wavelength LED sources provide an excitation signal for absorbance or fluorescence. The signal is measured by a photodiode for absorbance, and an optional photomultiplier tube for fluorescence. Dual absorbance and simultaneous absorbance and fluorescence are possible.

Software

MOS-LED is controlled through Spec-Lab software. **Bio-Logic** developed Spec-Lab to bring innovative measurement and analysis tools to occasional users and students. Spec-Lab offers the best of simple operation and advanced features.



GENERAL SPECIFICATIONS

- Single Berger ball mixing
- 8 ms dead time in manual mode
 - 5 ms with optional motor drive
- 30 µl sample per experiment
- 20 µl dead volume
- Variable mixing ratio
- Spec-Lab software included
- USB communication with PC
- Absorbance measurements standard
 - Fluorescence and dual absorbance optional

10 reasons to buy

SFM-100/MOS-LED

rather than classical manual stopped-flow

- Affordable
- Low sample consumption
- Plug and Play operation
- Compact
- User-friendly
- Integrated absorbance spectroscopy
- Optics/electronics optimized for kinetics
- Flexible and Modular
- Kinetics software included
- Teaching optimized

A ROBUST AND PRECISE STOPPED-FLOW

In the standard **SFM-100** both syringes are driven with a manual drive wheel. A precision brake and drive control gives shot to shot reproducibility better than 90%. A manual switch valve is used for a fast purge of the stop syringe. When the brake is released an LED indicates that new shot can be done.

The mixing ratio is controlled by changing the drive syringe diameter, with mixing ratios from 1:1 to 1:10 is possible.

A 18 μ l cuvette with double light path (1cm/1mm) is standard, and other cuvettes are available as options. Changing the cuvette is an easy 30 second operation.

WAVELENGTH SELECTION

Traditional stopped-flow optical systems use a monochromatic light source, coupled to an excitation monochromator. The design is flexible, but bulky and expensive. The **MOS-LED** uses efficient and inexpensive single wavelength sources based on LED technology. Sources for specific applications, such as tryptophan, can be selected and quickly installed in the system.

Compared to a bulky and expensive arc lamp source and monochromator, the LED source is major improvement in all important functions. The LED source in the **MOS-LED** gives better signal to noise performance than a standard bench spectrometers not designed for kinetics. The **MOS-LED** also automatically identifies the wavelength selected in Spec-Lab, and automatically calibrates the system.

FAST AND SENSITIVE ABSORBANCE

The **MOS-LED** uses a photodiode for absorbance measurements. Gain is automatically adjusted to operate in the optimum sensitivity range of the photodiode. Data can be collected every 100 μ s and is sent to a PC through a USB port. A ultra fast electronic shutter is integrated to **MOS-LED** to protect sample from photo bleaching. Signals as low as 1×10^{-3} A.U. can be measured easily.

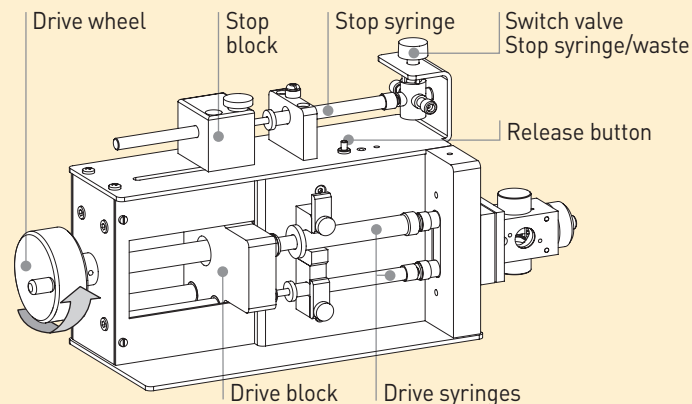

AN INNOVATIVE CONCEPT

- No more optical coupling issues
- No temperature artifacts
- No data acquisition speed limitation because of bench spectrometer or fluorimeter
- No trigger issues
- No more software issues with a software originally not designed for fast kinetics applications.

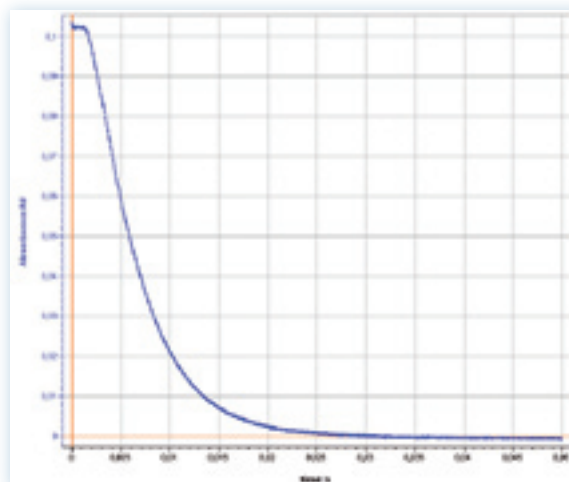

DCIP reduction by 10 mM ascorbic acid followed at 525 nm by manual mixing $k=180 \text{ s}^{-1}$ (dead time measured at 7.8 ms, pre-trigger 2 ms).

FLUORESCENCE & DUAL ABSORBANCE

A second detection channel is optional with the **SFM-100/MOS-LED**, and adds three detection modes: simple fluorescence, simultaneous fluorescence and absorbance and dual absorbance.

Designed specially for tryptophan fluorescence studies, it includes a photomultiplier tube, high energy 280nm LED, and cut-off filter. Pulse mode operation of the LED generates an intense excitation signal and acts as a virtual shutter to prevent photobleaching. A responsive acquisition circuit allows fast kinetics to be monitored with sampling to 400 μ s per point.

The PMT can be combined with another LED source for applications requiring fluorescence markers. Simultaneous absorbance and fluorescence is also possible, using a single LED for both detectors.

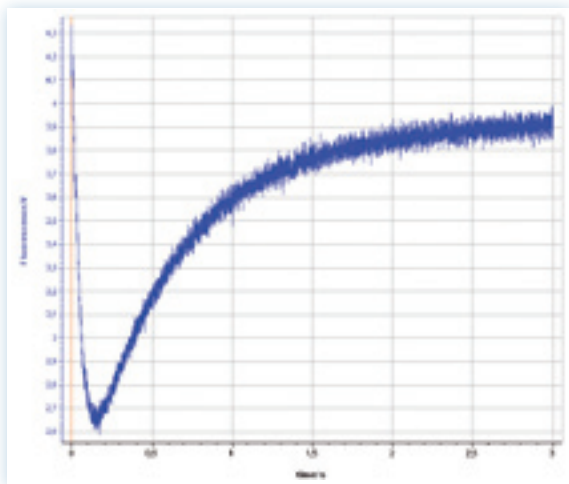

Lysozyme refolding by a 6 fold dilution: single shot in manual mode (0.5 mg/ml lysozyme in 6M GnD-HCL, excitation 280 nm, detection using 320 cut-off filter, 400 μ s sampling).

SYRINGE MOTOR DRIVE

The **MPS-10** motor drive option adds improved shot to shot reproducibility and reduced dead time to the **SFM-100**. The user sets the pushing phase speed according to the syringe sizes installed.

Dead time is reduced to 5 ms using the **MPS-10**, which makes **SFM-100** capable of research grade experiments. The **MPS-10** is a user installable option, so it can easily be added to a basic system when needed.



DUAL ABSORBANCE

The photomultiplier can be used as a second absorbance detector. Two excitation LEDs are used and switched on alternately. A single shot can be followed at two wavelengths simultaneously with a 100 μ s time base.

This unique mode is fully controlled in Spec-Lab, which indicates which LED is connected to the photodiode, and which is connected to the PMT.

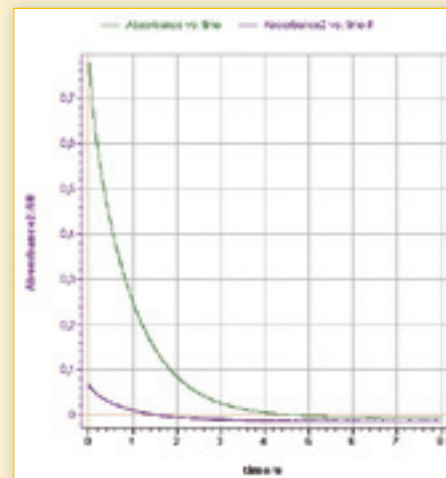

TEMPERATURE CONTROL

Temperature control accessory can be added. The **SFM-100** can then be connected to a circulating bath for temperature control. The observation head, syringes, mixer, and cuvette circulation path are linked to keep them at the same temperature. This reliable and design is used on our larger SFM models, and proven in daily use around the world.

EASY TO USE FULL CONTROL FOR MIXING, DATA COLLECTION, AND ANALYSIS

Spec-Lab controls the all of the mixing and detection functions of **SFM-100/MOS-LED**. It was designed to be easy for occasional users and students, Spec-Lab has the power and control needed by experienced kineticists. The user selects a detection technique, and software wizards guide him through the configuration steps.

INTUITIVE SELECTION OF ACQUISITION PARAMETERS

Spec-Lab automatically identifies LED wavelength for one or two simultaneous LED's, and automatically adjusts gain for optimum signal to noise ratio. Data can be collected using a linear time base or using an innovative sampling mode which adapts the sampling rate to the speed of the reaction.

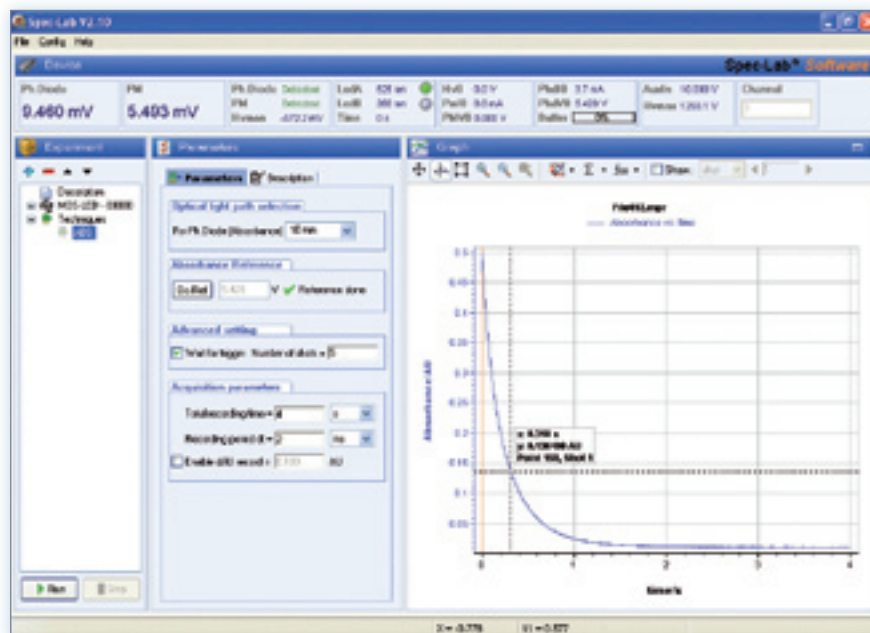

SIMPLE AND POWERFUL GRAPHIC INTERFACE

Complete or partial traces can be selected for viewing or analysis. Tags can be placed along curves for direct reading of specific points. Spec-Lab saves multi-shot experiments within the same data file, where individual traces can be selected and averages calculated. Spec-Lab also includes smoothing functions, and tools for multi-exponential fitting, rms noise measurement, normalization and subtraction.

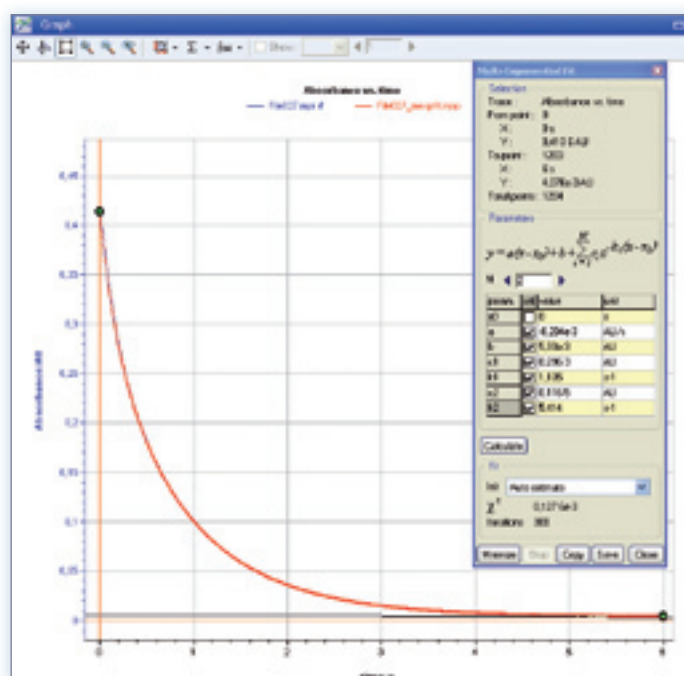

WHY CHOOSE THE SFM-100/MOS-LED FOR YOUR LAB ?

Robust **Fast and sensitive** **Flexible** **Easy to use** **No software license**
Benefits for researchers and teachers **Affordable**

Select exactly the configuration you need - absorbance only, absorbance/fluorescence, motor control, and excitation sources, for your current needs, and expand later as necessary.

The **SFM-100 / MOS-LED** is affordable. It provides solid, research grade stopped-flow performance and optical features at a price comparable to existing basic stopped flow systems. As a teaching system, or a backup research system, the **SFM-100/MOS-LED** is an unbeatable value.

The compact design of the **SFM-100/MOS-LED** make it easy to move from lab to lab, or to place in a fume hood or glove box. Plug and play setup eliminates the need for trained personnel to set up or move the system.

Benefits for students

Spec-Lab software is site licensed. Any user of the system can install Spec-Lab on their own PC and use it for shot design and data analysis away from the lab. Fitting tools and graphical options are available for report generation outside of the lab. Students can spend valuable lab time concentrating on experimental technique and data collection.

SPECIFICATIONS

SFM-100 Stopped Flow Mixer

Number of syringes	2
Number of mixers	1
Mixer type	Berger-Ball
Stop mechanism	Stop syringe
Drive mechanism	Single ram, manual drive standard, Motor drive with optional MPS-10
Mixing ratio range	1:1 to 1:10
Ratio control	Syringe change
Trigger	5 to 0 V TTL trigger out

Syringes

Syringes material	Glass (Teflon piston)
Syringe size	5 ml standard (10 ml; 2.5 ml; 1 ml optional)
Dead volume	20 µl
Minimum injection volume	30 µl

Observation head

Ports	2 detection, 2 excitation
Cuvette	Standard is quartz cuvette with 1 cm x 1 mm light path
Minimum dead time	8 ms (manual drive) 5 ms (with optional MPS-10 motor drive)
Material	PEEK, Viton (Kelraz o'rings optional)

General

Dimensions	32 x 11 x 13 cm SFM-100 29 x 22 x 15 cm MPS-10
Weight	5.6 kg SFM-100 5 kg MPS-10
Power	110 V-220 V

MOS-LED spectrometer

Detection mode	Absorbance standard Optional fluorescence, double abs., simultaneous fluo/abs.
Absorbance detector	Photodiode
Wavelength range	280-800 nm
Sensitivity in abs. mode	1.5×10^{-4} AU (524 nm, 1 ms sampling rate)
Fluorescence detector (optional)	Photomultiplier
Sensitivity in fluorescence mode	Noise 1.4% (measured with NATA 10 µM, exc. 280 nm, 320 nm cut-off, 400 µs sampling rate)

LED excitation sources

Wavelength	From 280 to 800 nm (contact factory)
------------	--------------------------------------

General

Dimensions	37 x 17 x 21 cm
Weight	4.5 kg
Communication	USB
Power	110 V-220 V

Temperature control

Temperature range	-10° C; +70° C
Temperature control	External water bath circulator (optional)

Software an PC

Control software	Spec-Lab (included)
PC	Requires Windows XP, Vista, 7 (32 bits) PC with available USB port (not included)

Specifications subject to change without notice

Bio-Logic, SAS
 1, rue de l'Europe
 38640 CLAIIX - France
 Tel.: +33 476 98 68 31
 Fax: +33 476 98 69 09
 www.bio-logic.info



Bio-Logic USA, LLC
 P.O. Box 30009
 Knoxville TN 37930 - USA
 Tel: +1 865 769 3800
 Fax: +1 865 769 3801
 www.bio-logic.us