

iglidur® F

Electrically conductive and strong. Extreme stiffening and hardening, besides being highly electrically conductive iglidur® F bearings can be used in dry operation only conditionally, but display full mechanical potentials with oil and fat lubrication.

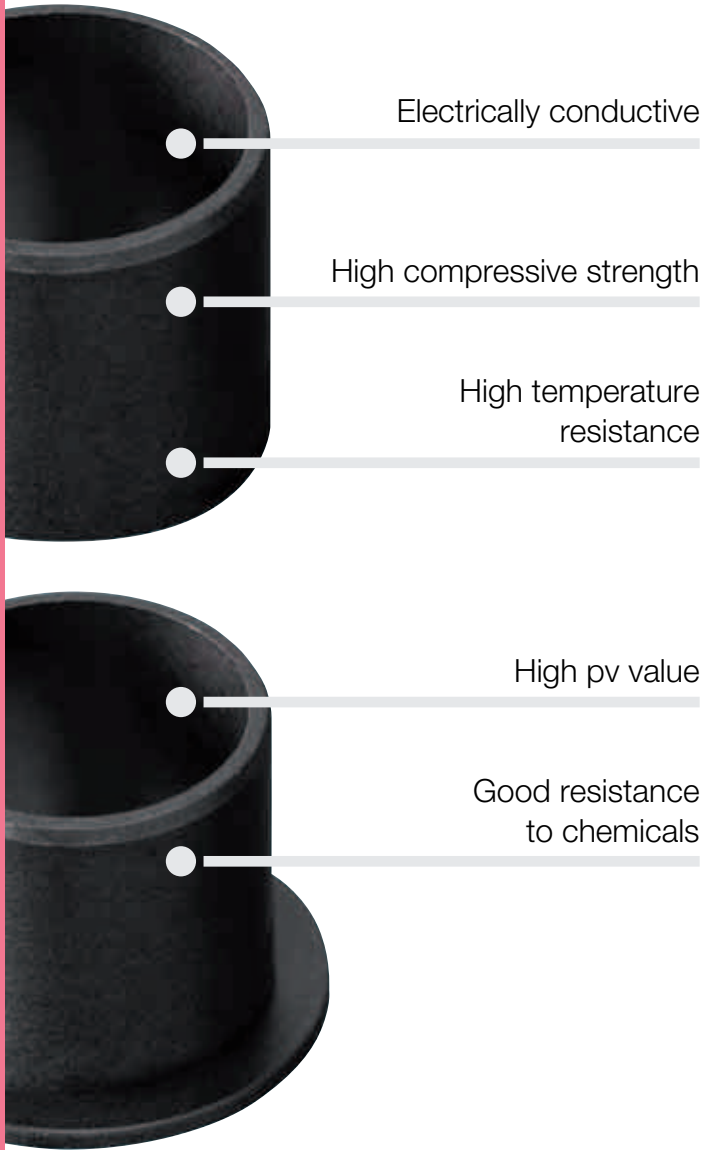

When to use it?

- When the bearing should be electrically conductive
- For high static loads



When not to use it?

- When mechanical reaming of the wall surface is necessary
▶ **iglidur® M250, page 107**
- When the highest wear resistance is needed
▶ **iglidur® W300, page 131**
- When very low coefficients of friction in the dry run are needed
▶ **iglidur® J, page 89**
- For underwater applications
▶ **iglidur® H370, page 347**
- When you need an universal bearing
▶ **iglidur® G, page 61**

Temperature

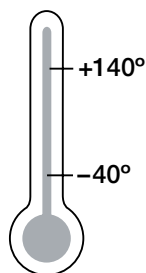

Product range

2 types
Ø 2–70 mm
more dimensions
on request



iglidur® F | Application Examples



Typical sectors of industry and application areas

- Textile technology
- Automotive etc.

Improve technology and reduce costs –
310 exciting examples for iglidur® plain bearings online

► www.igus.eu/eu/iglidur-applications

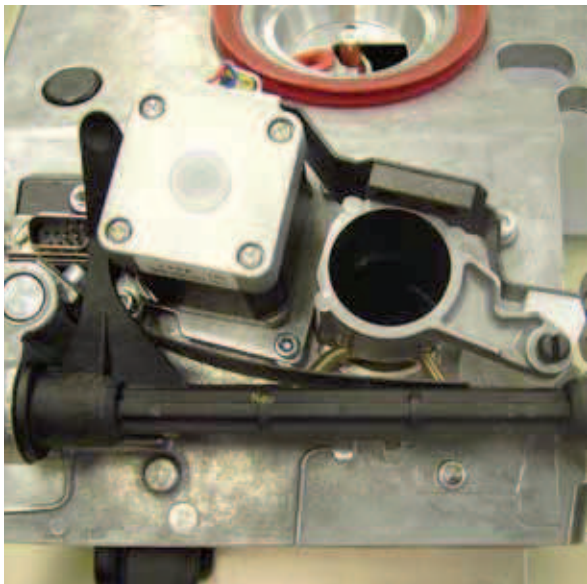

► www.igus.eu/spinningbox



► www.igus.eu/textile-machine

Material data

General properties	Unit	iglidur® F	Testing method
Density	g/cm ³	1.25	
Colour		black	
Max. moisture absorption at +23 °C/50 % r.h.	% weight	1.8	DIN 53495
Max. moisture absorption	% weight	8.4	
Coefficient of sliding friction, dynamic against steel	μ	0.1–0.39	
pv value, max. (dry)	MPa · m/s	0.34	
Mechanical properties			
Modulus of elasticity	MPa	11,600	DIN 53457
Tensile strength at +20 °C	MPa	260	DIN 53452
Compressive strength	MPa	98	
Max. recommended surface pressure (+20 °C)	MPa	105	
Shore D hardness		84	DIN 53505
Physical and thermal properties			
Max. long term application temperature	°C	+140	
Max. short term application temperature	°C	+180	
Min. application temperature	°C	-40	
Thermal conductivity	W/m · K	0.65	ASTM C 177
Coefficient of thermal expansion (at +23 °C)	K ⁻¹ · 10 ⁻⁵	12	DIN 53752
Electrical properties			
Specific volume resistance	Ωcm	< 10 ³	DIN IEC 93
Surface resistance	Ω	< 10 ²	DIN 53482

Table 01: Material data

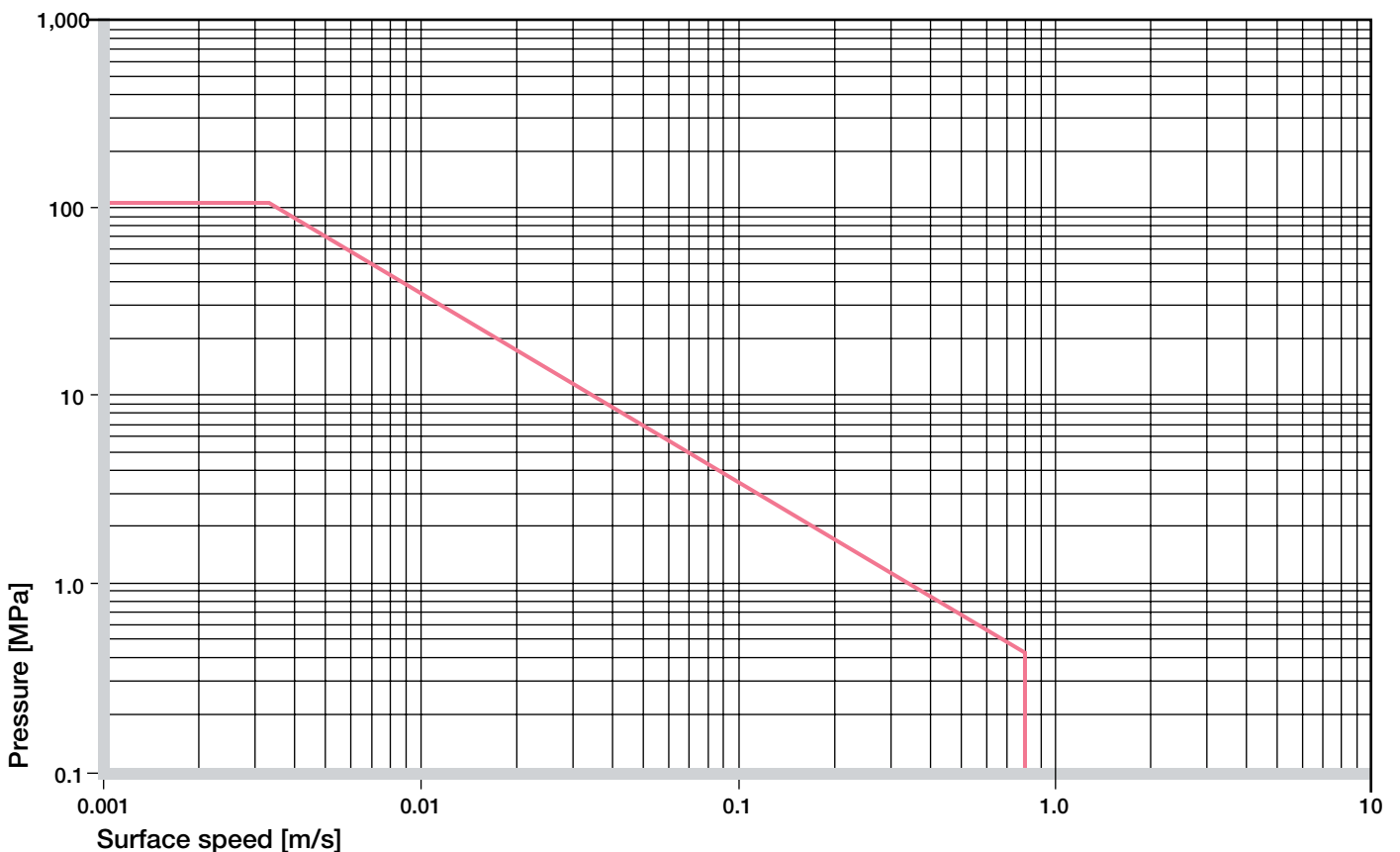

Graph 01: Permissible pv values for iglidur® F with a wall thickness of 1 mm dry running against a steel shaft at +20 °C, mounted in a steel housing

iglidur® F | Technical Data

Mechanical Properties

The recommended maximum surface pressure is a mechanical material parameter. No conclusions regarding the tribological properties can be drawn from this. With increasing temperatures, the compressive strength of iglidur® F plain bearings decreases. The Graph 02 shows this inverse relationship. However, at the longterm maximum temperature of +140°C the permissible surface pressure is almost 50 MPa.

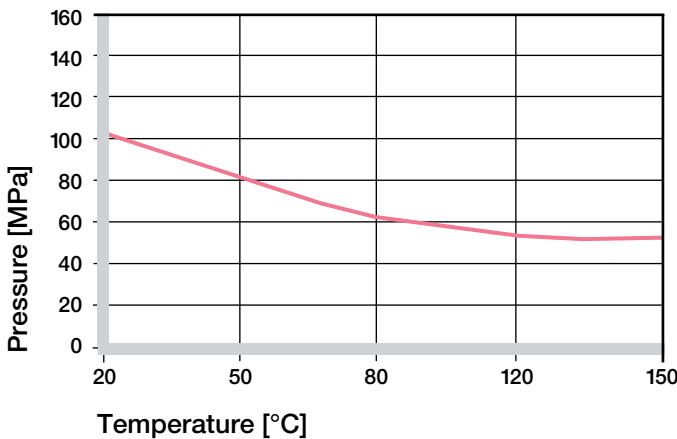

Graph 02: Recommended maximum surface pressure as a function of temperature (100 MPa at +20 °C)

When bearings need to be electrically conductive, especially in applications that should keep out static, the iglidur® F is the right choice. Moreover, the iglidur® F bearings are extremely pressure resistant. At room temperature, they could be statically loaded up to 100 MPa.

Graph 03 shows the elastic deformation of iglidur® F with radial loads. Under the maximum recommended surface pressure of 105 MPa, the deformation amounts to less than 3.5 %.

A plastic deformation can be negligible up to this pressure load. It is however also dependent on the period of exposure.

► Surface Pressure, [page 43](#)

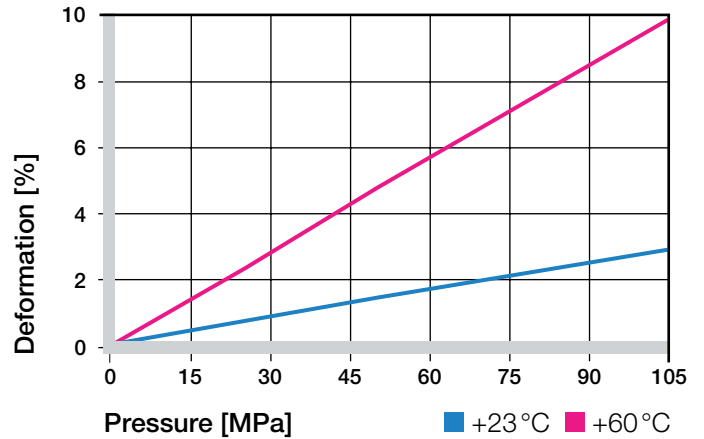

Graph 03: Deformation under pressure and temperature

Permissible Surface Speeds

The maximum permitted surface speeds are based on the operation period and the type of motion. A bearing is the most stressed in long-term rotating motions. Here the maximum speed for the iglidur® F bearing is 0.8 m/s.

The maximum values specified in Table 02 are attained only at minimum pressure loads. In practice these limit values are not often attained due to interactions.

► Surface Speed, [page 45](#)

m/s	Rotating	Oscillating	Linear
Continuous	0.8	0.6	3
Short term	1.5	1.1	6

Table 02: Maximum running speed

Temperatures

The ambient temperatures strongly influence the features of bearings. The short-term permitted maximum temperature is +180 °C. Long-term operating temperatures should not exceed +140 °C.

With increasing temperatures, the compressive strength of iglidur® F bearings decreases. Graph 02 clarifies this connection. The wear too rises.

► Application Temperatures, [page 46](#)

iglidur® F	Application temperature
Minimum	-40 °C
Max. long term	+140 °C
Max. short term	+180 °C
Add. securing is required from	+105 °C

Table 03: Temperature limits

Friction and Wear

The coefficients of friction in the dry operation are not so favorable in iglidur® F bearings like in many other iglidur® materials. However iglidur® bearings can be lubricated without any problems, and iglidur® F bearings attain excellent results compared among the lubricated iglidur® bearings.

► Coefficients of Friction and Surfaces, **page 48**

► Wear Resistance, **page 49**

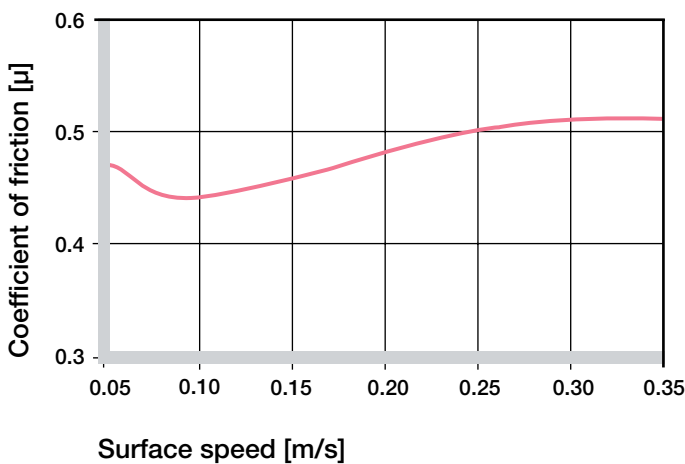

Graph 04: Coefficient of friction as a function of the running speed, $p = 0.75 \text{ MPa}$

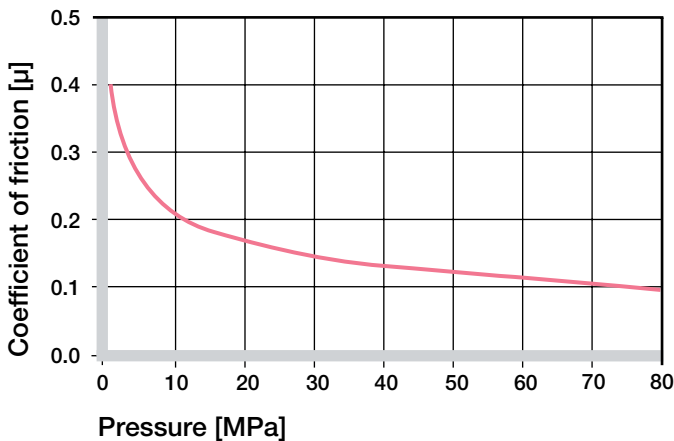

Graph 05: Coefficient of friction as a function of the pressure, $v = 0.01 \text{ m/s}$

Shaft Materials

Graphs 07–09 display a summary of the results of tests with different shaft materials conducted with bearings made of iglidur® F. In the lowest load range, the hard-chromed shafts prove to be the most suitable counter partner in rotating applications with iglidur® F bearings. It behaves otherwise in pivoting applications (see Graph 09) At 2 MPa loads, the V2A shaft and the hard-chromed shaft are more favorable than the Cf53 shaft, having much higher coefficients of wear altogether than in rotations.

Please contact us in case the shaft material scheduled by you is not included in these diagrams.

► Shaft Materials, **page 51**

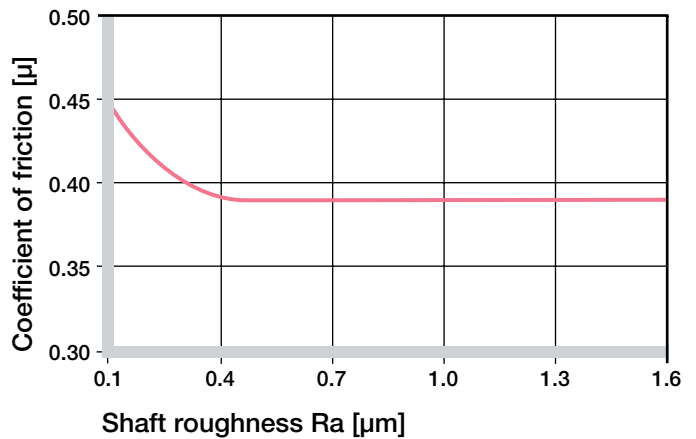

Graph 06: Coefficient of friction as function of the shaft surface (Cf53 hardened and ground steel)

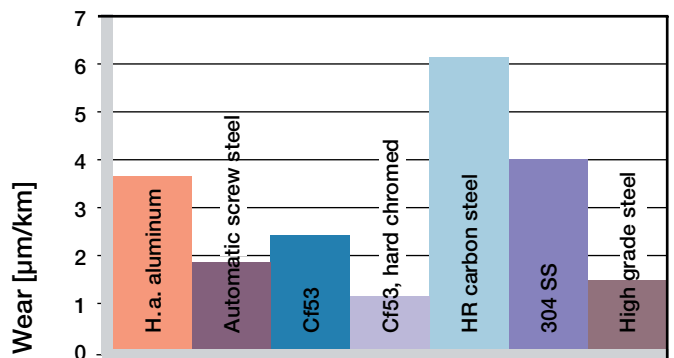

Graph 07: Wear, rotating with different shaft materials, pressure $p = 0.75 \text{ MPa}$, $v = 0.5 \text{ m/s}$

iglidur® F | Technical Data

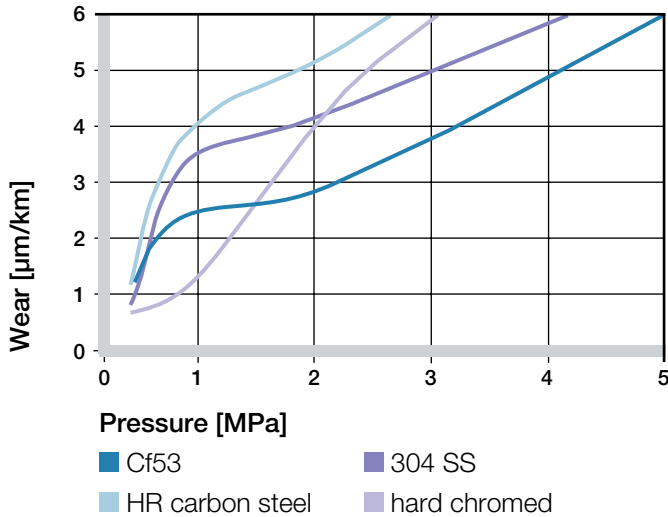

Graph 08: Wear with different shaft materials in rotational operation, as a function of the pressure

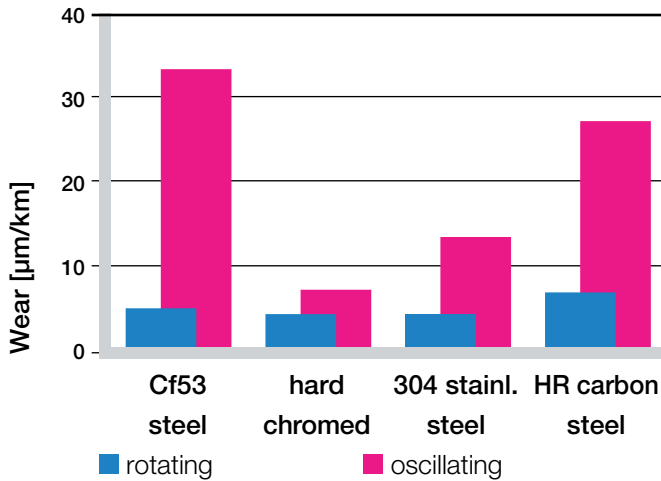

Graph 09: Wear for rotating and oscillating applications with different shaft materials, p = 2 MPa

iglidur® F	Dry	Greases	Oil	Water
C.o.f. µ	0.08–0.15	0.09	0.04	0.04

Table 04: Coefficient of friction against steel (Ra = 1 µm, 50 HRC)

Additional Properties

Chemical Resistance

iglidur® F plain bearings have a good chemical resistance. They have a high resistance to lubricants, even at high temperatures (around +120 °C). Hence the iglidur® F bearings are particularly suitable for applications that call for lubrication necessitated by other parts. The iglidur® F is not affected by most weak organic and inorganic acids.

► Chemical Table, page 974

Medium	Resistance
Alcohol	+ to 0
Hydrocarbons	+
Greases, oils without additives	+
Fuels	+
Diluted acids	0 to –
Strong acids	–
Diluted alkalines	+
Strong alkalines	+ to 0

+ resistant 0 conditionally resistant – not resistant

All data given at room temperature [+20 °C]

Table 05: Chemical resistance

Radiation Resistance

Plain bearings of iglidur® F are radiation resistant up to a radiation intensity of $3 \cdot 10^2$ Gy.

UV Resistance

iglidur® F plain bearings are permanently resistant to UV radiation.

Vacuum

iglidur® F plain bearings outgas in a vacuum. Use in a vacuum environment is only possible with dehumidified bearings.

Electrical Properties

iglidur® F plain bearings are electrically conductive.

Volume resistance	< $10^3 \Omega\text{cm}$
Surface resistance	< $10^2 \Omega$

Moisture Absorption

The moisture absorption of iglidur® F plain bearings is approximately 1.8% in standard atmosphere. The saturation limit in water is 8.4%. This must be taken into account along with the other applicable conditions.

Maximum moisture absorption

At +23 °C/50% r.h. 1.8% weight

Max. moisture absorption 8.4% weight

Table 06: Moisture absorption

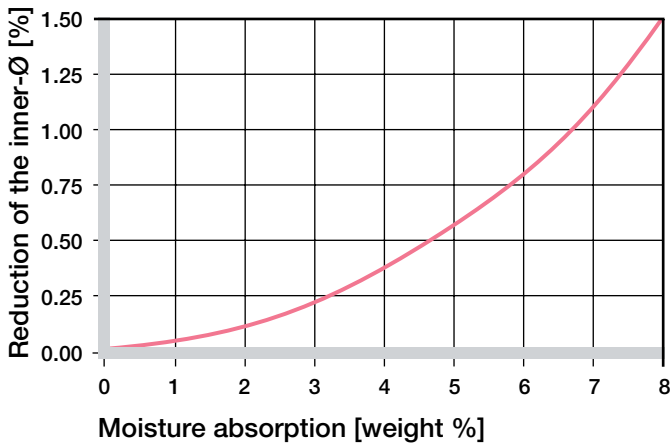

Graph 10: Effect of moisture absorption on plain bearings

Installation Tolerances

iglidur® F bearings are standard bearings for shafts with h-tolerance (recommended minimum h9).

After the installation in a housing bore with the tolerance H7, the inner diameter of the bearing automatically adjusts to the D11 tolerance.

► Testing Methods, page 55

Diameter d1 [mm]	Shaft h9 [mm]	iglidur® F D11 [mm]	Housing H7 [mm]
up to 3	0-0.025	+0.020 +0.080	0 +0.010
> 3 to 6	0-0.030	+0.030 +0.105	0 +0.012
> 6 to 10	0-0.036	+0.040 +0.130	0 +0.015
> 10 to 18	0-0.043	+0.050 +0.160	0 +0.018
> 18 to 30	0-0.052	+0.065 +0.195	0 +0.021
> 30 to 50	0-0.062	+0.080 +0.240	0 +0.025
> 50 to 80	0-0.074	+0.100 +0.290	0 +0.030

Table 07: Important tolerances for plain bearings according to ISO 3547-1 after pressfit

Sleeve bearing

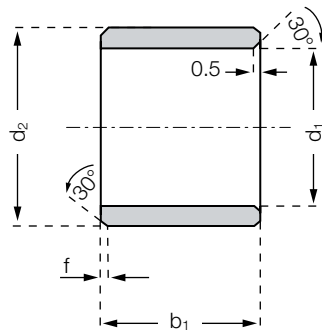

Order key

FSM-0203-03



Length b1
Outer diameter d2
Inner diameter d1
Metric
Type (Form S)
Material iglidur® F

Dimensions according to ISO 3547-1 and special dimensions

Chamfer in relation to the d1

d1 [mm]:	Ø 1-6	Ø 6-12	Ø 12-30	Ø > 30
f [mm]:	0.3	0.5	0.8	1.2

Dimensions [mm]

Part number	d1	d1-Tolerance*	d2	b1 h13
FSM-0203-03	2.0	+0.020 +0.080	3.5	3.0
FSM-0304-03	3.0	+0.020 +0.080	4.5	3.0
FSM-0405-04	4.0	+0.030 +0.105	5.5	4.0
FSM-0507-05	5.0	+0.030 +0.105	7.0	5.0
FSM-0507-08	5.0	+0.030 +0.105	7.0	8.0
FSM-0608-06	6.0	+0.030 +0.105	8.0	6.0
FSM-0608-08	6.0	+0.030 +0.105	8.0	8.0
FSM-0608-10	6.0	+0.030 +0.105	8.0	10.0
FSM-0608-13	6.0	+0.030 +0.105	8.0	13.8
FSM-0709-10	7.0	+0.040 +0.130	9.0	10.0
FSM-0709-12	7.0	+0.040 +0.130	9.0	12.0
FSM-0810-08	8.0	+0.040 +0.130	10.0	8.0
FSM-0810-10	8.0	+0.040 +0.130	10.0	10.0
FSM-0810-15	8.0	+0.040 +0.130	10.0	15.0
FSM-1012-06	10.0	+0.040 +0.130	12.0	6.0
FSM-1012-10	10.0	+0.040 +0.130	12.0	10.0
FSM-1214-10	12.0	+0.050 +0.160	14.0	10.0
FSM-1214-15	12.0	+0.050 +0.160	14.0	15.0
FSM-1416-15	14.0	+0.050 +0.160	16.0	15.0
FSM-1517-15	15.0	+0.050 +0.160	17.0	15.0
FSM-1517-20	15.0	+0.050 +0.160	17.0	20.0
FSM-1618-15	16.0	+0.050 +0.160	18.0	15.0
FSM-1820-15	18.0	+0.050 +0.160	20.0	15.0
FSM-1820-20	18.0	+0.050 +0.160	20.0	20.0
FSM-2022-14	20.0	+0.065 +0.195	22.0	14.5

* after pressfit. Testing methods ► page 55



delivery available
time from stock



prices price list online
www.igus.eu/eu/f



order part number
example FSM-0203-03



Sleeve bearing

Dimensions [mm]

Part number	d1	d1-Tolerance*	d2	b1 h13
FSM-2022-20	20.0	+0.065 +0.195	22.0	20.0
FSM-2023-15	20.0	+0.065 +0.195	23.0	15.0
FSM-2023-20	20.0	+0.065 +0.195	23.0	20.0
FSM-2225-15	22.0	+0.065 +0.195	25.0	15.0
FSM-2528-20	25.0	+0.065 +0.195	28.0	20.0
FSM-2832-20	28.0	+0.065 +0.195	32.0	20.0
FSM-2832-30	28.0	+0.065 +0.195	32.0	30.0
FSM-3034-20	30.0	+0.065 +0.195	34.0	20.0
FSM-3034-30	30.0	+0.065 +0.195	34.0	30.0
FSM-3034-40	30.0	+0.065 +0.195	34.0	40.0
FSM-3236-30	32.0	+0.080 +0.240	36.0	30.0
FSM-3539-30	35.0	+0.080 +0.240	39.0	30.0
FSM-3539-40	35.0	+0.080 +0.240	39.0	40.0
FSM-4044-30	40.0	+0.080 +0.240	44.0	30.0
FSM-4044-50	40.0	+0.080 +0.240	44.0	50.0
FSM-4550-50	45.0	+0.080 +0.240	50.0	50.0
FSM-5055-40	50.0	+0.080 +0.240	55.0	40.0
FSM-5560-50	55.0	+0.100 +0.290	60.0	50.0
FSM-6065-60	60.0	+0.100 +0.290	65.0	60.0

* after pressfit. Testing methods ► page 55

iglidur® F | Product Range

Flange bearing

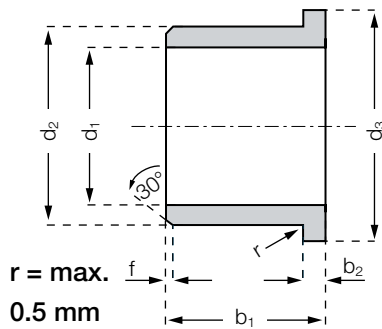

Order key

FFM-0405-04



Length b1
Outer diameter d2
Inner diameter d1
Metric
Type (Form F)
Material iglidur® F

Dimensions according to ISO 3547-1 and special dimensions

Chamfer in relation to the d1

d1 [mm]:	Ø 1-6	Ø 6-12	Ø 12-30	Ø > 30
f [mm]:	0.3	0.5	0.8	1.2

Dimensions [mm]

Part number	d1	d1-Tolerance*	d2	d3 d13	b1 h13	b2 -0.14
FFM-0405-04	4.0	+0.030 +0.105	5.5	9.5	4.0	0.75
FFM-0405-06	4.0	+0.030 +0.105	5.5	9.5	6.0	0.75
FFM-0507-05	5.0	+0.030 +0.105	7.0	11.0	5.0	1.0
FFM-0608-08	6.0	+0.030 +0.105	8.0	12.0	8.0	1.0
FFM-0810-06	8.0	+0.040 +0.130	10.0	15.0	6.0	1.0
FFM-0810-09	8.0	+0.040 +0.130	10.0	15.0	9.0	1.0
FFM-1012-06	10.0	+0.040 +0.130	12.0	18.0	6.0	1.0
FFM-1012-08	10.0	+0.040 +0.130	12.0	15.0	8.0	1.0
FFM-1012-09	10.0	+0.040 +0.130	12.0	18.0	9.0	1.0
FFM-1012-15	10.0	+0.040 +0.130	12.0	18.0	15.0	1.0
FFM-1012-18	10.0	+0.040 +0.130	12.0	18.0	18.0	1.0
FFM-1214-09	12.0	+0.050 +0.160	14.0	20.0	9.0	1.0
FFM-1214-12	12.0	+0.050 +0.160	14.0	20.0	12.0	1.0
FFM-1416-12	14.0	+0.050 +0.160	16.0	22.0	12.0	1.0
FFM-1416-17	14.0	+0.050 +0.160	16.0	22.0	17.0	1.0
FFM-1517-12	15.0	+0.050 +0.160	17.0	23.0	12.0	1.0
FFM-1517-17	15.0	+0.050 +0.160	17.0	23.0	17.0	1.0
FFM-1618-17	16.0	+0.050 +0.160	18.0	24.0	17.0	1.0
FFM-1820-12	18.0	+0.050 +0.160	20.0	26.0	12.0	1.0
FFM-1820-17	18.0	+0.050 +0.160	20.0	26.0	17.0	1.0
FFM-2023-21	20.0	+0.065 +0.195	23.0	30.0	21.0	1.5
FFM-2528-21	25.0	+0.065 +0.195	28.0	35.0	21.0	1.5
FFM-3034-26	30.0	+0.065 +0.195	34.0	42.0	26.0	2.0
FFM-3236-26	32.0	+0.080 +0.240	36.0	45.0	26.0	2.0
FFM-3539-26	35.0	+0.080 +0.240	39.0	47.0	26.0	2.0

* after pressfit. Testing methods ► page 55



delivery available
time from stock



prices price list online
www.igus.eu/eu/f



order part number
example FFM-0405-04



Flange bearing

Dimensions [mm]

Part number	d1	d1-Tolerance*	d2	d3 d13	b1 h13	b2 -0.14
FFM-4044-30	40.0	+0.080 +0.240	44.0	52.0	30.0	2.0
FFM-4044-40	40.0	+0.080 +0.240	44.0	52.0	40.0	2.0
FFM-4550-50	45.0	+0.080 +0.240	50.0	58.0	50.0	2.0
FFM-5055-40	50.0	+0.080 +0.240	55.0	63.0	40.0	2.0
FFM-6065-40	60.0	+0.100 +0.290	65.0	73.0	40.0	2.0
FFM-7075-40	70.0	+0.100 +0.290	75.0	83.0	40.0	2.0

* after pressfit. Testing methods ► page 55