



Shaping the Future Together

CLG2020A

Forklifts

CE ISO9001
ISO14001

| | |
|-----------------------|---------|
| Rated Capacity | 2000 kg |
| Load Center | 500 mm |
| Service Weight | 3600 kg |
| Max. Lifting Height | 3000 mm |
| Fork Free Lift Height | 105 mm |



GUANGXI LIUGONG MACHINERY CO., LTD.
No.1 Liutai Road, Liuzhou, Guangxi
China 545007
T +86 772 3886124 3886125
F +86 772 3886122
www.liugong.com
overseas@liugong.com



| Item | | | | CLG2020A |
|--|-----------------------|-------|------------------|--------------------|
| Rated capacity | | kg | | 2000 |
| Load center | | mm | | 500 |
| Max. lifting height | | mm | H ₃ | 3000 |
| Fork free lift height | | mm | H ₂ | 105 |
| Max. lifting speed (loaded) | | mm/s | | 350 |
| Tilt angle (fwd / bwd) | | | α / β | 7°/7° |
| Transmissions type | | | | Double motor drive |
| Max. travel speed | | km/h | | 15/15 |
| Max. gradeability laden (S2 60min/5min), unladen (S2 60min/5min) | | % | | 8/27, 13/44 |
| Max.Traction (S2 60min/5min) | | kN | | 4.5/14 |
| Turning radius | | mm | W _a | 2010 |
| Dimensions | Length | mm | L ₂ | 2150 |
| | Width | mm | W | 1100 |
| | Mast lowered height | mm | H ₁ | 2020 |
| | Mast extended height | mm | H ₄ | 4050 |
| | Overhead guard height | mm | H ₆ | 2015 |
| Ground clearance | | mm | m ₂ | 95 |
| Fork size (length x width x thick) | | mm | | 1070×120×40 |
| Wheel base | | mm | y | 1510 |
| Track | Front | mm | B ₁₀ | 915 |
| | Rear | mm | B ₁₁ | 880 |
| Fork hang(fwd/bwd) | | mm | X | 370/270 |
| Min. right angle aisle width | | mm | | 3815 |
| Min. right angle aisle width | | mm | | 2450 |
| Service weight | | kg | | 3600 |
| Tyres | Q'TY(F/R) | | | 2/2 |
| | Size | Front | | 200/50-10 |
| | | Rear | | 16×6-8 |
| Battery | | Model | | 6PzS690 |
| Pump | Model | | | F20 |
| | Rated speed | | r/min | 2000 |
| | Displacement | | ml/r | 20 |

Dimensions

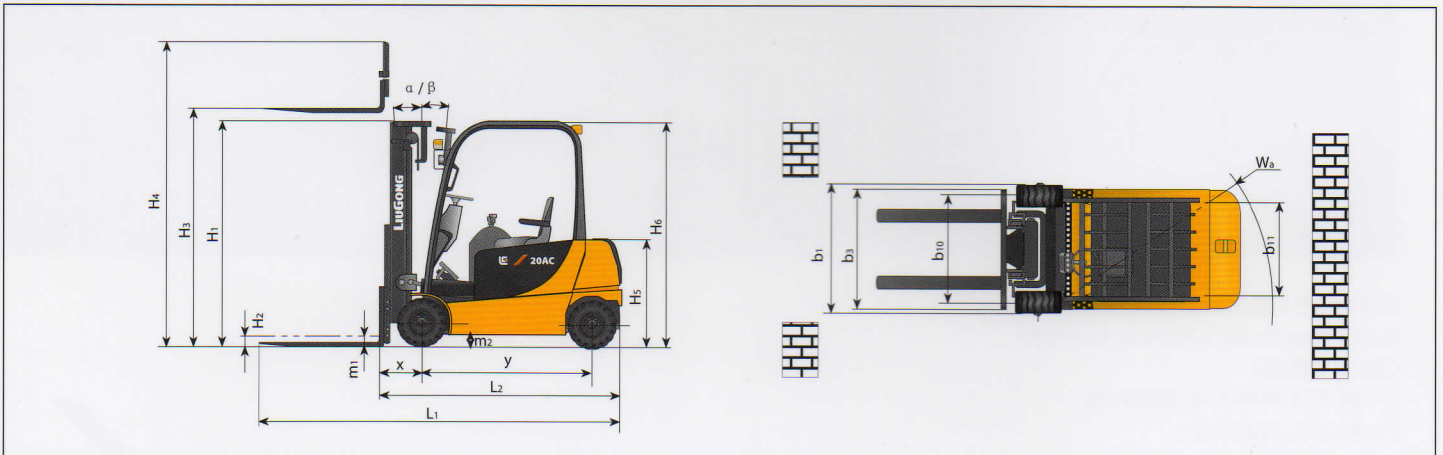

Specifications and design are subject to change without prior notice.
Machines shown may include optional equipment.