

Advantages:

- Burner sequence control
- Electronic compound, up to 4 channels
- Connects to control system
- Simple to program
- 10-bits resolution
- Can be operated from PC
- Integrated load control
- Integrated leakage test
- Integrated O₂ /CO control



One thing is of primary importance for modern firing installations: efficiency. That applies to the operation of the equipment as well as to its erection and commissioning.

LAMTEC has the right solution: the ETAMATIC

As the name suggests (ETA is the Greek letter η used in engineering as the symbol for efficiency), the ETAMATIC is characterized by efficiency in every aspect. Its compact form contains everything needed for complete burner control.

It combines the advantages of an electronic firing compound with up to 4 positioning elements with an electronic burner sequence control. Since a output regulator, O_2 controller or CO controller (with gas), leakage test and flame monitor are also integrated, you have everything you need to control and monitor your burner in one device. Fail-safe. This gives you the solution to nearly all your firing tasks. Safety interlock circuits, sensors and detectors are connected directly to the ETAMATIC. The need for supplementary relays and wiring is vastly reduced. Under the right conditions, the ETAMATIC allows the complete burner control system to be mounted at the burner itself. An integrated device like the ETAMATIC also offers significant advantages during commissioning. Through minimisation of the wiring and the unified user interface, sources of error are minimised from the very beginning, while the search for faults is

assisted through appropriate and relevant advice. The ETAMATIC is available with 4 three-state step outputs, or with one continuous output (for rotary speed control) and 3 three-state step outputs.

The firing mechanism and the compound can be parameterised to adapt them to very different firing tasks. Separate settings can be made for oil and gas with and without a pilot burner. The integrated leakage test can optionally be made before ignition or after switch-off. Start-up without pre-ventilation with gas in accordance with EN676 is possible.

The compound curves that have been set can be shifted during operation by the integrated O_2 control. This enables compensation for factors that could influence the combustion.

If you are burning gas, you can do even more: the LAMTEC CO control is able to run your burner with the maximum of possible efficiency.

Operating and error messages are displayed in plain text in the appropriate language. An operating hours counter is integrated, and also counts the burner operating hours with gas and oil. The start-ups for gas and oil are also separately counted.

If desired, the ETAMATIC can also perform output regulation of the burner. It is possible to switch between 2 set values, e.g. for reduced night-time power or heat holding operation. External set value adjustment (weather response) and start-up control can be used.

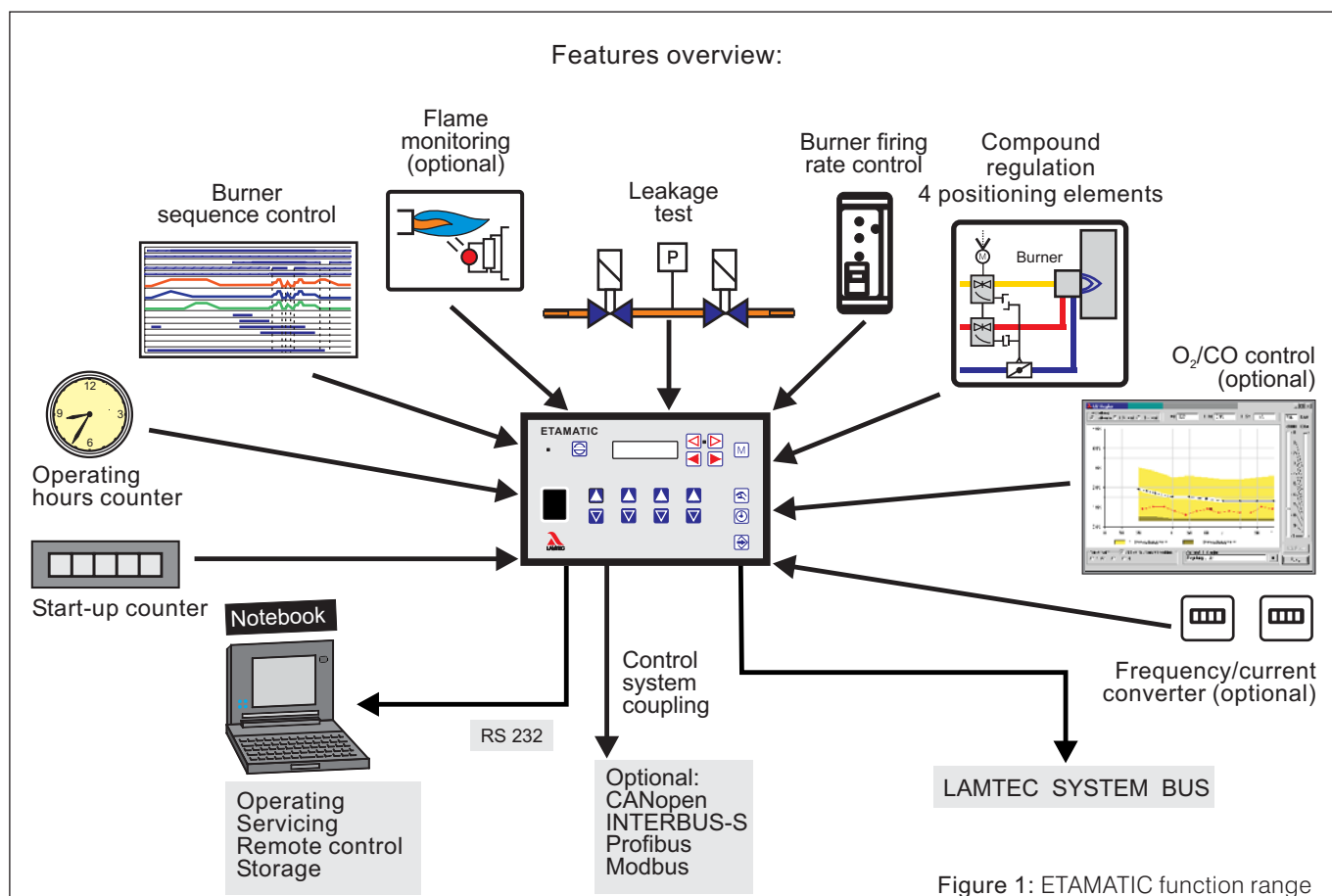

Figure 1: ETAMATIC function range

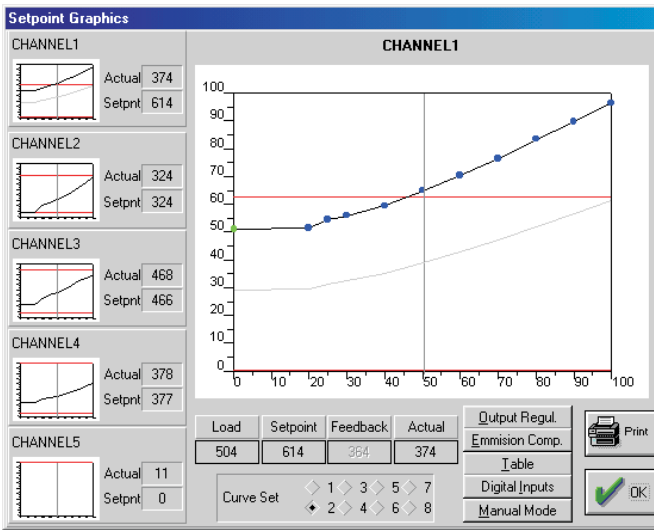

Figure 2: Visualisation of the compound curves through the remote control software

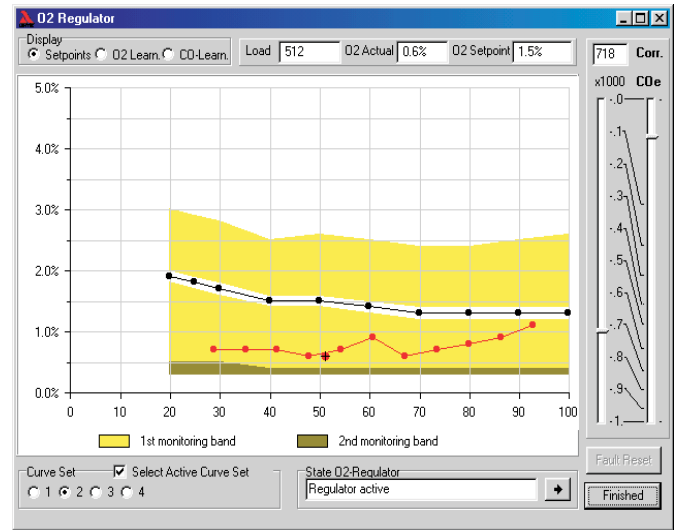

Figure 3: Visualisation of the O₂ and CO setpoint-curve with its monitoring-band-gaps when using the ETAMATIC's integrated O₂ or CO controller

An ETAMATIC always has a LAMTEC SYSTEM BUS connection on board. The LAMTEC SYSTEM BUS links LAMTEC devices together. Easily, quickly, and without extensive wiring. This allows additional signal outputs to be implemented, and fault indicating devices to be connected.

A software module O₂/CO control is integrated into the ETAMATIC. In combination with the O₂/CO-measurement devices LT1/LT2 via the LAMTEC SYSTEM BUS, every firing installation can be maintained

constantly at the ideal operating point, independently of environmental conditions such as temperature and air pressure. Using the CO probe KS1 in combination with O₂ probe, you get a failsafe CO control. The intelligence of the ETAMATIC reduces the air till CO starts to occur. Then it increases the air only one step and your burner will run with the best possible efficiency. The ETAMATIC can be effectively combined with existing control systems. It "speaks" the language of almost every conventional fieldbus.

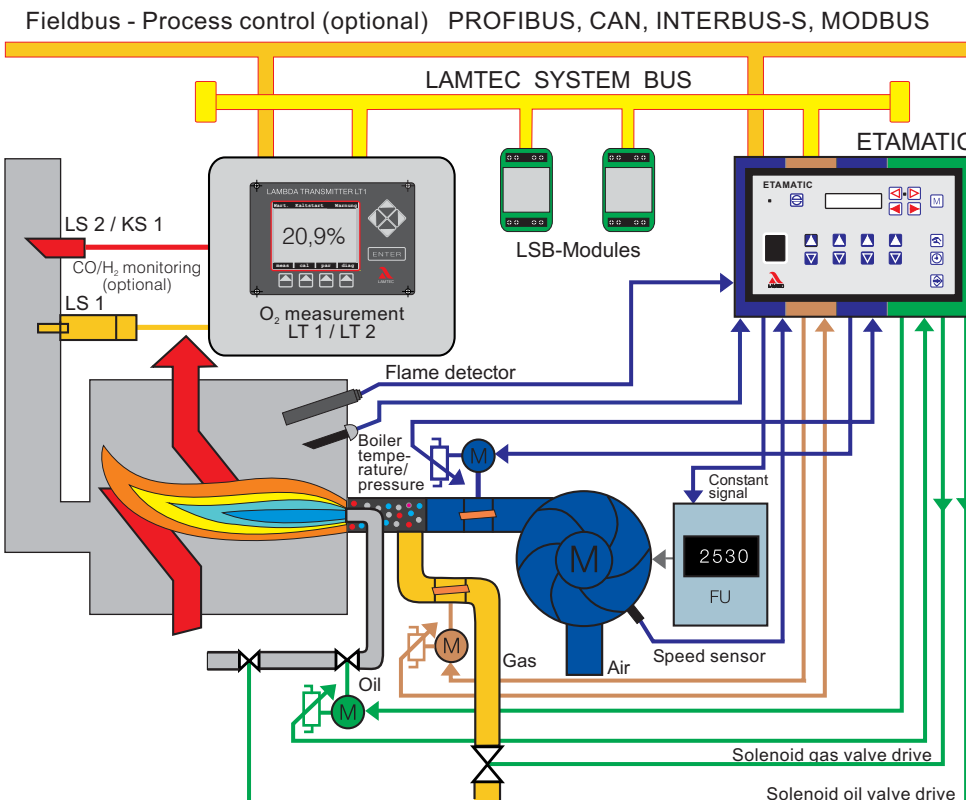

Figure 4: Burner control and firing optimisation via the LAMTEC SYSTEM BUS

The ETAMATIC has been tested by TÜV, and satisfies both, the relevant European Standards (EN) and the requirements of TRD 604, for continuous operation.

An additional PC interface provides valuable assistance for the work of commissioning the ETAMATIC. A laptop can be used to control the device remotely, and both, the set configuration and the curve data can be archived. If it should ever be necessary, a replacement unit can be prepared for operation within seconds: the stored data is simply read in.

The ETAMATIC can even be interrogated from your office if an industrial modem is used. If a malfunction should occur, the cause can be detected without having to be on site.

Electrical power supply	from 115 V - 15 % to 230 V +10 % 50/60 Hz	Analog inputs	Selectable potentiometer 1 - 5 k Ω or 0/4...20 mA current signal. Optional: Direct speed measurement signal
Power consumption	approx. 50 VA	Resolution: per analog input	999 digits, 10 bits
Ambient temperature Operation: Transport and storage	+ 0°C...+ 60°C -25°C...+ 60°C	Three-state-step: Recommended run time of the positioning drive:	30 s...60 s
Display	Alphanumeric display, 2x16 characters can display set value, load value, status, actual feedback value, set feedback value, digital inputs, constant positioning output value, correction input and correction range or running text display	Constant outputs: Load:	0...10 V > 5 k Ω 0/4...20 mA < 600 Ω
Permiss. ambient humidity	Class F, DIN 40 040	Digital outputs:	Main gas 1, main gas 2, oil valves, ignition valves, ignition transformer, fan, oil pump, fault
Inputs and outputs	14 digital inputs, 24V 16 digital outputs, 230V 1 analog output (ETAMATIC S) 3 analog inputs	Storage of the set values and variable data:	in EEPROM, up to 20 (type 11) points per curve with linear interpolation
Digital signal inputs	The ETAMATIC's self-tests will not allow the parasitic capacitance on the lines connected to the digital inputs to exceed 2.2 μ F. The length of the cables should not exceed 100 m	Number of curve-sets:	2 per channel (e.g. for oil/gas combined burner)
Load preset	Selectable potentiometer 1 - 5 k Ω , (0/4...20mA) current signal or three-state-step positioning output, direct PT 100 actuation (if the load regulator is used)	Number of programmings:	Unlimited (EEPROM)
		Interfaces:	1 serial interface on 25-pole sub-D socket, only addressable with adapter, RS 232 (standard setting 19200 baud, no parity, 8 data bits, 1 stop bit) and LAMTEC SYSTEM BUS
		BUS coupling:	Via external adapter connected to LSB for these protocols: Interbus-S (Phoenix) Profibus DP Modbus CANopen Ethernet (Modbus TCP)

Dimensional drawings:

