



VIBRATING LEVEL SWITCHES

VIBRATING PROBE LEVEL SWITCHES FOR LIQUIDS AND SOLIDS

PRINCIPLE OF OPERATION FOR ALL VIBRATING PROBE LEVEL SWITCHES

The operating principle is the same for all vibrating probe level switches. A piezo-electric crystal is used to force a blade to oscillate at its fundamental frequency (natural resonance). When the blades come into contact with the process medium the natural frequency of oscillation is damped; the electronics sense the change in frequency which causes the unit to switch.

The different electronic outputs to choose from allows the user to switch a load on/off or to interface directly with a computer. The units can be programmed to sense high or low level and failsafe high or low, with adjustable sensitivity to eliminate false switching. The switch is only sensitive at the tip so minimising the effect of build-up on tank walls.

ADVANTAGES OF VIBRATING PROBES

- ◆ No mechanical moving parts to wear
- ◆ No maintenance required
- ◆ Simple to install - no adjustments required
- ◆ Unaffected by environmental changes
- ◆ Unaffected by dust clouds and agitation
- ◆ Maximum versatility

SWITCHES FOR LIQUID APPLICATIONS

TF & MTF SERIES

As the damping effect (resistance to vibration) of low viscosity liquids is very small, it is common to use two relatively wide blades to sense the presence of liquid levels. These blades can be short in length for minimal intrusion into the vessel or for use in pipes.

THE TF SERIES

This rugged design of switch is used throughout the process industries. It is available with a wide range of flanged or screwed process connections and can have extensions, enabling the probe to reach 3 metres into a tank if required.

The wetted parts of standard switches are 316 stainless steel but special Halar coated and Hastelloy switches are used for extremely corrosive applications and hygienic probes are available for the food industry.

The switch has visual indication of its on/off status and a test point on the side of the housing to allow an operator to check the function of the switch. An intrinsically safe and explosion proof version of the switch is available for hazardous areas.

THE MTF SERIES

This is designed specifically for OEM equipment and has a smaller and less expensive configuration, but retains the status LED and test point featured in the TF series.

APPLICATIONS FOR LIQUID SWITCHES

- ◆ Overfill Protection
- ◆ High & Low level alarms
- ◆ Pump protection
- ◆ Dry pipe detection
- ◆ Hygienic application
- ◆ Wet Pipe detection

The TF Series for
Process Applications



The MTF Low Cost
Series for OEM



SWITCHES FOR SOLIDS APPLICATIONS

The design of a vibrating level switch for solids must be fundamentally different to the design described for liquids. If two large parallel blades were used on powders or solids it would be too easy for product to build-up and become lodged between the blades causing the oscillations of the switch to stop regardless of product level.

For solids applications on products ranging from cornflakes to coal, it is preferable to have only one blade in contact with the product. This eliminates the potential for bridging between the forks and ensures that the switch does not give false alarms.

DP120, 140 & 150 DIAMOND POINT

The design of the Diamond Point produces the most rugged but sensitive switch for solids applications. The hollow diamond shaped blade houses the second vibrating rod inside. The blade is very strong in the vertical direction to withstand falling solids and to ensure that product does not build upon it, but retains its flexibility and sensitivity in the horizontal mode enabling it to sense products with very low bulk densities.

DP600/660

The DP600 series uses the piezo element to excite an 85mm long stainless steel rod to its resonant frequency of 460Hz. When the material covers the rod it stops the vibration.

The DP600 is suitable for use on pellets and granules. It will detect the presence of solid materials with bulk density greater than 90 grams per litre. It is not suitable for sticky materials or materials that tend to hang-up.

The DP660 model is a low-cost OEM product designed specifically to be supplied in volume and fitted into other companies products. It has a 1 inch NPT or DIN 2999 G1 process connection and a PNP or relay output. This is also suitable for products with bulk density of 90 grams per litre or greater.

TYPICAL SOLIDS APPLICATIONS

- ◆ Powered milk
- ◆ Frozen chips
- ◆ Beans
- ◆ Sugar
- ◆ Sweets
- ◆ Coffee beans
- ◆ Coffee (ground)
- ◆ Peanuts
- ◆ Tobacco
- ◆ Grain
- ◆ Tea (leaf)
- ◆ Salt
- ◆ Flour
- ◆ Spices
- ◆ Soda
- ◆ Animal food
- ◆ Cornflakes
- ◆ Pellets
- ◆ Carbon black
- ◆ Chemicals
- ◆ Foundry sand
- ◆ Wood shavings
- ◆ Chalk
- ◆ Styrofoam
- ◆ Cellulose
- ◆ Glass (ground)
- ◆ Granular plastics
- ◆ Powdered clay
- ◆ Polystyrene
- ◆ Gravel
- ◆ Sawdust
- ◆ Filler materials
- ◆ Cement
- ◆ Lime

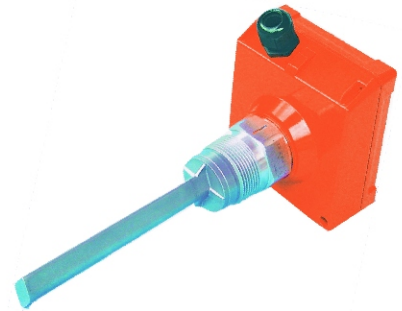

Diamond Point DP120, 130, 140 & 150



DP600 Series



660 Series Low Cost for OEM

SWITCHES FOR LIQUID APPLICATIONS

MTF SERIES LOW COST LEVEL SWITCH

This compact low cost switch has a rugged 316 stainless steel body and stainless steel forks for use in a wide range of liquids. MTF is the simple answer to your level switch needs.

FEATURES

- ◆ Low cost
- ◆ 3/4" mounting suitable for pipes or tanks
- ◆ Hygienic mounting for food industry use
- ◆ Small fork size for minimal intrusion into vessel
- ◆ 'PULSE' LED shows status of the switch
- ◆ Protection against reverse polarity and short circuit connection
- ◆ Magnetic test point

BENEFITS

- ◆ Operates on virtually any liquid
- ◆ Continuous operating temperature of 150°C
- ◆ Pressure to 100 bar G
- ◆ Specific operating frequency avoids false switching from plant vibration
- ◆ Industry standard DIN plug electrical connection for simple installation
- ◆ Direct load switching model suits all supplies: 24 to 264V ac/dc, 50/60Hz
- ◆ Solid state PNP output for direct interface to PLCs

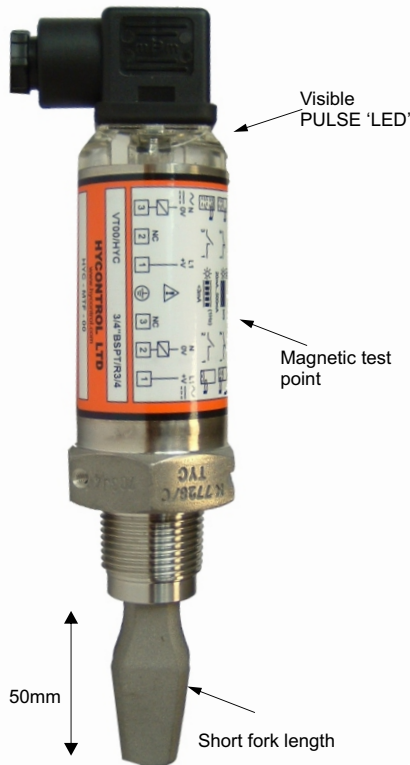

MTF SERIES PART NUMBERING & PRODUCT SELECTOR

Code	Product																												
HYC-MTF-	MTF Series Stainless Steel																												
	<table border="1"> <thead> <tr> <th>Code</th> <th>Output</th> </tr> </thead> <tbody> <tr> <td>0</td> <td>Direct Load Switching</td> </tr> <tr> <td>1</td> <td>PNP transistor (PLC)</td> </tr> </tbody> </table>	Code	Output	0	Direct Load Switching	1	PNP transistor (PLC)																						
Code	Output																												
0	Direct Load Switching																												
1	PNP transistor (PLC)																												
	<table border="1"> <thead> <tr> <th>Code</th> <th>Process Connection</th> <th>Temperature</th> <th>Pressure</th> </tr> </thead> <tbody> <tr> <td>0</td> <td>3/4" BSPT</td> <td>150°C</td> <td>100 bar</td> </tr> <tr> <td>3</td> <td>1" BSPT (R1")</td> <td>150°C</td> <td>100 bar</td> </tr> <tr> <td>5</td> <td>3/4" NPT</td> <td>150°C</td> <td>100 bar</td> </tr> <tr> <td>F</td> <td>1" BSPP (G1")</td> <td>150°C</td> <td>100 bar</td> </tr> <tr> <td>7</td> <td>2" Tri Clover Hand Polished</td> <td>150°C</td> <td>30 bar</td> </tr> <tr> <td>L</td> <td>1" BSPP (G1") Semi-extended</td> <td>150°C</td> <td>100 bar</td> </tr> </tbody> </table>	Code	Process Connection	Temperature	Pressure	0	3/4" BSPT	150°C	100 bar	3	1" BSPT (R1")	150°C	100 bar	5	3/4" NPT	150°C	100 bar	F	1" BSPP (G1")	150°C	100 bar	7	2" Tri Clover Hand Polished	150°C	30 bar	L	1" BSPP (G1") Semi-extended	150°C	100 bar
Code	Process Connection	Temperature	Pressure																										
0	3/4" BSPT	150°C	100 bar																										
3	1" BSPT (R1")	150°C	100 bar																										
5	3/4" NPT	150°C	100 bar																										
F	1" BSPP (G1")	150°C	100 bar																										
7	2" Tri Clover Hand Polished	150°C	30 bar																										
L	1" BSPP (G1") Semi-extended	150°C	100 bar																										

HYC-MTF- [] Part number

Model nos. for order			Dimensions			
Direct load switching	PNP switching	Mounting thread	A	B	C	D
MTF00	MTF10	3/4" BSPP	69	50	188	N/A
MTF05	MTF15	3/4" NPT	69	50	188	N/A
MTF03	MTF13	1" BSPP	69	50	188	N/A
MTF0F	MTF1F	1" BSPP	78	60	201	N/A
MTF07	MTF17	51mm 2" Tri-clover	N/A	50	188	
MTF0L	MTF1L	Semi-extended	116	98	239	N/A

SWITCHES FOR LIQUID APPLICATIONS

TF SERIES - FOR PROCESS PLANTS

FEATURES

- ◆ ¾" and 1" threaded (BSPT, BSPP, NPT) as standard or extended lengths to 3m
- ◆ Choice of international flanges and range of hygienic fittings
- ◆ Versatile switch outputs - Relay, Direct load switching, PLC/PNP and IS NAMUR
- ◆ ATEX hazardous area approval for flameproof (EExd) and intrinsically safe (EExia) applications
- ◆ Hastelloy or Halar/PFA coating for chemical resistance
- ◆ Continuous operating temperature up to 150°C and pressure up to 100 bar G

SPECIAL FEATURES

TF Series has a status indicating 'PULSE' LED which can be seen at all times through a lens in the cover. The LED will flash (once per second) when the TF Series is 'off' and will be constantly lit when the TF Series is 'on'. The LED gives an indication that the switch is functioning correctly and gives a visual indication of the state of the wetside.

A mode switch allows the user to select whether the TF Series is to be set to switch from wet to dry (typically low alarm) or from dry to wet (typically high alarm). A time delay from 0.3, 1, 3, 10, or 30 seconds may be selected to eliminate false switching when the liquid surface is turbulent or agitated.

A magnetic test point on the side of the housing, allows the user to perform a functional test of the TF Series. By touching a magnet on the point indicated on the side of the switch the output will change state for as long as the magnet is present, allowing testing of any connected alarms or other outputs.

ELECTRONICS

Standard two core cable with any power supply from 24 to 260V ac or 24 to 60Vdc is used to connect TF Series with the load and achieve directly load switching. The output acts as a simple SPST switch that changes with liquid presence. Alternatively use the switching function of the SPCO relay for volt free contacts. The TF Series also has the option of electronics which can be interfaced directly to a PLC using the PNP transistor output model (three-wire).

Intrinsically Safe (IS) units to ATEX EExia approval interface directly with standard NAMUR (DIN 19234, IEC 60947-5-6) isolation amplifiers.

SHORT FORK TECHNOLOGY

Using Short Fork Technology offers many advantages to the user enabling the switch to operate in small vessels or pipes. Extensive research has maximised the operational effectiveness of the fork to enable it to operate with aerated liquids and slurries, and to function even when coated with product.

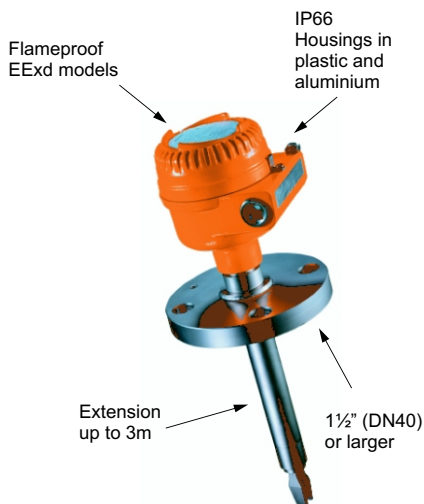
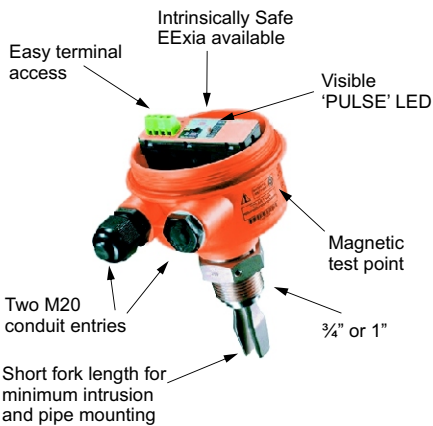

SIL 2 APPROVED

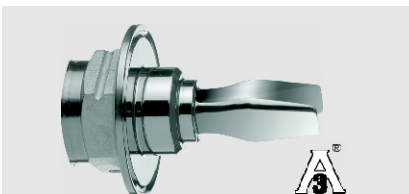

The industry standard 51mm Tri-clover mounting flange, with its hand polished wetside is suitable for use where 3A and EHEDG approvals are required.

TF SERIES

PART NUMBERING & PRODUCT SELECTOR

Code	Product																																																								
HYC-TF-	TF Series																																																								
	<table border="1" style="width: 100%; border-collapse: collapse;"> <thead> <tr> <th style="width: 10%;">Code</th> <th style="width: 90%;">Material</th> </tr> </thead> <tbody> <tr> <td>TD</td> <td>316L Stainless Steel</td> </tr> <tr> <td>TE</td> <td>Fully certified and traceable 316L SS. (3.1b)</td> </tr> <tr> <td>TF</td> <td>Halar coated 316L Stainless Steel</td> </tr> <tr> <td>TG</td> <td>Halar Coated fully certified and traceable 316L SS (3.1b)</td> </tr> <tr> <td>TC</td> <td>Hastelloy</td> </tr> </tbody> </table>	Code	Material	TD	316L Stainless Steel	TE	Fully certified and traceable 316L SS. (3.1b)	TF	Halar coated 316L Stainless Steel	TG	Halar Coated fully certified and traceable 316L SS (3.1b)	TC	Hastelloy																																												
Code	Material																																																								
TD	316L Stainless Steel																																																								
TE	Fully certified and traceable 316L SS. (3.1b)																																																								
TF	Halar coated 316L Stainless Steel																																																								
TG	Halar Coated fully certified and traceable 316L SS (3.1b)																																																								
TC	Hastelloy																																																								
	<table border="1" style="width: 100%; border-collapse: collapse;"> <thead> <tr> <th style="width: 10%;">Code</th> <th style="width: 90%;">Process Connection</th> </tr> </thead> <tbody> <tr><td>5A</td><td>3/4" BSPT (R) N/A in Halar</td></tr> <tr><td>1A</td><td>1" BSPT (R) N/A in Halar</td></tr> <tr><td>5B</td><td>3/4" BSPP (G) N/A in Halar</td></tr> <tr><td>1B</td><td>1" BSPP (G) N/A in Halar</td></tr> <tr><td>5D</td><td>3/4" NPT N/A in Halar</td></tr> <tr><td>1D</td><td>1" NPT N/A in Halar</td></tr> <tr><td>1P</td><td>1" BSPP (can be used with SK267) N/A in Halar</td></tr> <tr><td>6R</td><td>1.5" Tri-Clover N/A in Halar</td></tr> <tr><td>2R</td><td>2" Tri-Clover N/A in Halar</td></tr> <tr><td>6K</td><td>DN40 PN10/16</td></tr> <tr><td>6L</td><td>DN40 PN25/40</td></tr> <tr><td>2K</td><td>DN50 PN10/16</td></tr> <tr><td>2L</td><td>DN50 PN25/40</td></tr> <tr><td>7K</td><td>DN65 PN10/16</td></tr> <tr><td>7L</td><td>DN65 PN25/40</td></tr> <tr><td>3K</td><td>DN80 PN10/16</td></tr> <tr><td>3L</td><td>DN80 PN25/40</td></tr> <tr><td>4K</td><td>DN100 PN10/16</td></tr> <tr><td>4L</td><td>DN100 PN25/40</td></tr> <tr><td>6G</td><td>1.5" ANSI 150</td></tr> <tr><td>6H</td><td>1.5" ANSI 300</td></tr> <tr><td>2G</td><td>2" ANSI 150</td></tr> <tr><td>2H</td><td>2" ANSI 300</td></tr> <tr><td>3G</td><td>3" ANSI 150</td></tr> <tr><td>3H</td><td>3" ANSI 300</td></tr> <tr><td>4G</td><td>4" ANSI 150</td></tr> <tr><td>4H</td><td>4" ANSI 300</td></tr> </tbody> </table>	Code	Process Connection	5A	3/4" BSPT (R) N/A in Halar	1A	1" BSPT (R) N/A in Halar	5B	3/4" BSPP (G) N/A in Halar	1B	1" BSPP (G) N/A in Halar	5D	3/4" NPT N/A in Halar	1D	1" NPT N/A in Halar	1P	1" BSPP (can be used with SK267) N/A in Halar	6R	1.5" Tri-Clover N/A in Halar	2R	2" Tri-Clover N/A in Halar	6K	DN40 PN10/16	6L	DN40 PN25/40	2K	DN50 PN10/16	2L	DN50 PN25/40	7K	DN65 PN10/16	7L	DN65 PN25/40	3K	DN80 PN10/16	3L	DN80 PN25/40	4K	DN100 PN10/16	4L	DN100 PN25/40	6G	1.5" ANSI 150	6H	1.5" ANSI 300	2G	2" ANSI 150	2H	2" ANSI 300	3G	3" ANSI 150	3H	3" ANSI 300	4G	4" ANSI 150	4H	4" ANSI 300
Code	Process Connection																																																								
5A	3/4" BSPT (R) N/A in Halar																																																								
1A	1" BSPT (R) N/A in Halar																																																								
5B	3/4" BSPP (G) N/A in Halar																																																								
1B	1" BSPP (G) N/A in Halar																																																								
5D	3/4" NPT N/A in Halar																																																								
1D	1" NPT N/A in Halar																																																								
1P	1" BSPP (can be used with SK267) N/A in Halar																																																								
6R	1.5" Tri-Clover N/A in Halar																																																								
2R	2" Tri-Clover N/A in Halar																																																								
6K	DN40 PN10/16																																																								
6L	DN40 PN25/40																																																								
2K	DN50 PN10/16																																																								
2L	DN50 PN25/40																																																								
7K	DN65 PN10/16																																																								
7L	DN65 PN25/40																																																								
3K	DN80 PN10/16																																																								
3L	DN80 PN25/40																																																								
4K	DN100 PN10/16																																																								
4L	DN100 PN25/40																																																								
6G	1.5" ANSI 150																																																								
6H	1.5" ANSI 300																																																								
2G	2" ANSI 150																																																								
2H	2" ANSI 300																																																								
3G	3" ANSI 150																																																								
3H	3" ANSI 300																																																								
4G	4" ANSI 150																																																								
4H	4" ANSI 300																																																								
	<table border="1" style="width: 100%; border-collapse: collapse;"> <thead> <tr> <th style="width: 10%;">Code</th> <th style="width: 90%;">Output</th> </tr> </thead> <tbody> <tr><td>S</td><td>Direct load switching</td></tr> <tr><td>B</td><td>PNP transistor (PLC)</td></tr> <tr><td>R</td><td>SPDT relay</td></tr> <tr><td>C</td><td>IS NAMUR</td></tr> </tbody> </table>	Code	Output	S	Direct load switching	B	PNP transistor (PLC)	R	SPDT relay	C	IS NAMUR																																														
Code	Output																																																								
S	Direct load switching																																																								
B	PNP transistor (PLC)																																																								
R	SPDT relay																																																								
C	IS NAMUR																																																								
	<table border="1" style="width: 100%; border-collapse: collapse;"> <thead> <tr> <th style="width: 10%;">Code</th> <th style="width: 90%;">Wetside Finish</th> </tr> </thead> <tbody> <tr><td>1</td><td>Standard electropolished N/A in Halar</td></tr> <tr><td>2</td><td>Hand polished to better than Ra <0.8um N/A in Halar</td></tr> </tbody> </table>	Code	Wetside Finish	1	Standard electropolished N/A in Halar	2	Hand polished to better than Ra <0.8um N/A in Halar																																																		
Code	Wetside Finish																																																								
1	Standard electropolished N/A in Halar																																																								
2	Hand polished to better than Ra <0.8um N/A in Halar																																																								
	<table border="1" style="width: 100%; border-collapse: collapse;"> <thead> <tr> <th style="width: 10%;">Code</th> <th style="width: 90%;">Approvals & Housing</th> </tr> </thead> <tbody> <tr><td>NE</td><td>No approval. GFN Housing M20 entry</td></tr> <tr><td>NF</td><td>No approval. GFN Housing 1/2"NPT entry</td></tr> <tr><td>AE</td><td>ATEX & FM (IS) GFN Housing M20 entry</td></tr> <tr><td>AF</td><td>ATEX & FM (IS) GFN Housing 1/2"NPT entry</td></tr> <tr><td>EG</td><td>ATEX (EExd) Aluminium Housing M20 entry</td></tr> <tr><td>FJ</td><td>FM (EExd) Aluminium Housing 3/4"NPT entry</td></tr> </tbody> </table>	Code	Approvals & Housing	NE	No approval. GFN Housing M20 entry	NF	No approval. GFN Housing 1/2"NPT entry	AE	ATEX & FM (IS) GFN Housing M20 entry	AF	ATEX & FM (IS) GFN Housing 1/2"NPT entry	EG	ATEX (EExd) Aluminium Housing M20 entry	FJ	FM (EExd) Aluminium Housing 3/4"NPT entry																																										
Code	Approvals & Housing																																																								
NE	No approval. GFN Housing M20 entry																																																								
NF	No approval. GFN Housing 1/2"NPT entry																																																								
AE	ATEX & FM (IS) GFN Housing M20 entry																																																								
AF	ATEX & FM (IS) GFN Housing 1/2"NPT entry																																																								
EG	ATEX (EExd) Aluminium Housing M20 entry																																																								
FJ	FM (EExd) Aluminium Housing 3/4"NPT entry																																																								
	<table border="1" style="width: 100%; border-collapse: collapse;"> <thead> <tr> <th style="width: 10%;">Code</th> <th style="width: 90%;">Options</th> </tr> </thead> <tbody> <tr><td>A</td><td>Standard length for threaded and tri-clover sensor N/A in Halar</td></tr> <tr><td>H</td><td>Standard length for flanged sensor</td></tr> <tr><td>L</td><td>Short extension</td></tr> <tr><td>B</td><td>150mm extension</td></tr> <tr><td>C</td><td>300mm extension</td></tr> <tr><td>D</td><td>500mm extension</td></tr> <tr><td>E***</td><td>Up to 1000mm</td></tr> <tr><td>E***</td><td>1001mm to 2000mm N/A in Halar</td></tr> <tr><td>E***</td><td>2001mm to 3000mm N/A in Halar</td></tr> </tbody> </table>	Code	Options	A	Standard length for threaded and tri-clover sensor N/A in Halar	H	Standard length for flanged sensor	L	Short extension	B	150mm extension	C	300mm extension	D	500mm extension	E***	Up to 1000mm	E***	1001mm to 2000mm N/A in Halar	E***	2001mm to 3000mm N/A in Halar																																				
Code	Options																																																								
A	Standard length for threaded and tri-clover sensor N/A in Halar																																																								
H	Standard length for flanged sensor																																																								
L	Short extension																																																								
B	150mm extension																																																								
C	300mm extension																																																								
D	500mm extension																																																								
E***	Up to 1000mm																																																								
E***	1001mm to 2000mm N/A in Halar																																																								
E***	2001mm to 3000mm N/A in Halar																																																								
HYC-TF-	<table border="1" style="width: 100%; border-collapse: collapse;"> <tr> <td style="width: 10%;"></td> <td style="width: 10%;"></td> <td style="width: 10%;"></td> <td style="width: 10%;"></td> <td style="width: 10%;"></td> <td style="width: 10%;"></td> <td style="width: 10%;"></td> <td style="width: 10%;"></td> <td style="width: 10%;"></td> <td style="width: 10%;"></td> </tr> </table>																																																								

The existence of a type number does not imply that all combinations of part numbers are available. Consult Hycontrol.

SPECIFICATION FOR LIQUID SWITCHES

<u>Construction</u>	<u>MTF</u>	<u>TF</u>
Housing Enclosure	304 Stainless Steel	Glass filled Nylon Aluminium for EExd
Wetside Materials	316 St. St.	316 St. St. or Hastelloy or Halar
Hygienic	Polished Stainless Steel	Polished Stainless Steel
Safety Integrity Level	N/A	SIL2 (IS only)
Electrical Connection	4-way DIN Plug	2 x M20 / 1/2" NPT / 3/4" NPT
Extended Length	No	Up to 3m

Operating Condition

Process Temperature	-40°C + 150°C	
Ambient Temperature	-40°C + 80°C (Derated to 50°C if 150°C Wetside)	
Process Pressure	-0.25 bar to 100 bar at 50°CCL	
Liquid Specific Gravity	0.6 to 2.0	
Liquid Viscosity	.2 to 10,000 cps	
Switch Point	13mm from tip or edge	
Hysteresis	+ 1mm nominal in water	
Switching Delay	Fixed 1 sec.	Selectable 0.3, 100, 3, 10 & 30 sec

Electrical

Direct load switch	24 – 264 V AC 50/60Hz or 24 to 60 V DC	
PNP	26 – 60 V DC	
Maximum switch load	500mA	
Maximum peak load	5A	

<u>Protection</u> - Mechanical	Housing IP 66	
- Electrical	24 – 264 V AC reverse polarity and short circuit protected	

Approvals

EMC Directive	EN61326	EN50081-1 & EN50082-2
Hazardous Area	N/A	ATEX II 1GD EExia IIC T5
	N/A	ATEX II 1GD EExd IIC T5
LV Directive	EN61010	

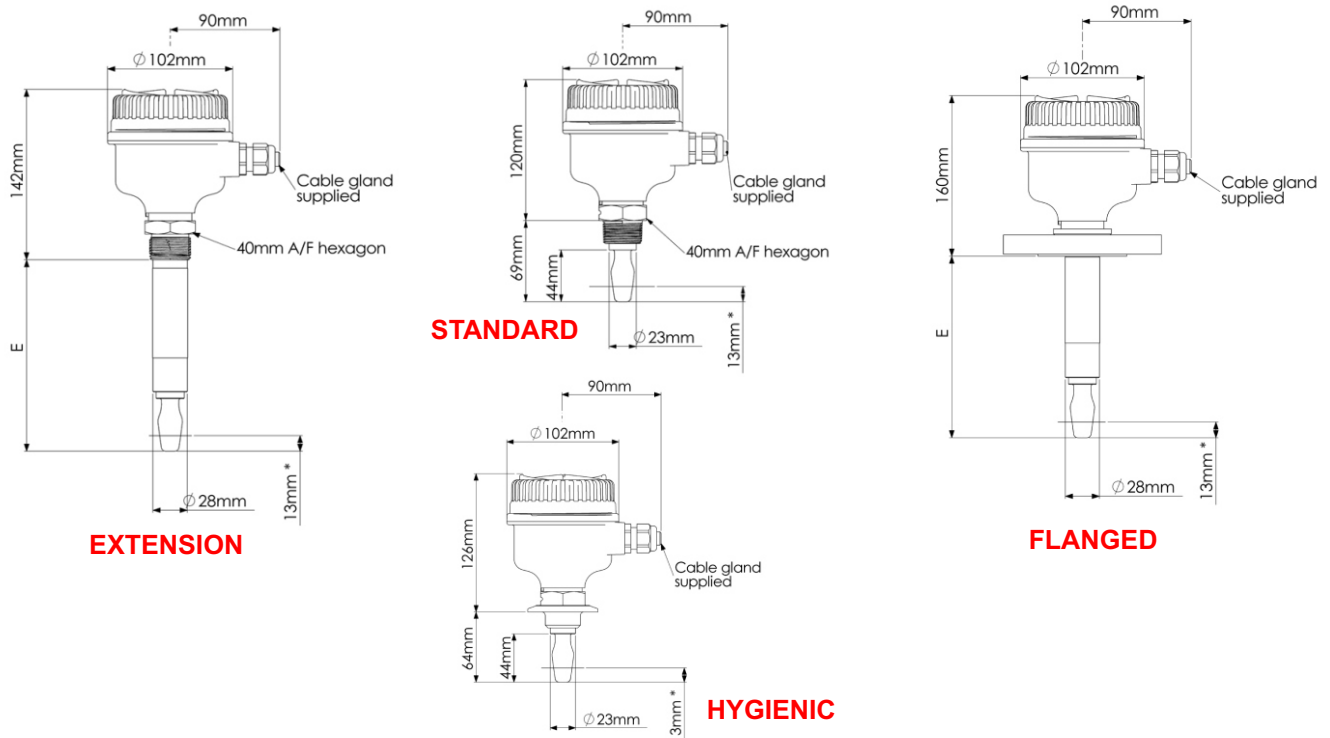

LEVEL SWITCHES FOR SOLIDS

The Diamond Point Level Switch is designed specifically for use with dry products ranging from stone aggregates and heavy materials such as cement, to very low density materials like cornflakes and fine powder or flour.

Its unique principle of operation and shape ensures that it is self-cleaning and because it is only sensitive at its tip it is not influenced by build-up on the silo walls.

DIAMOND POINT: SINGLE BLADE

The single blade design with its reinforced diamond shaped vibrating blade prevents material build-up or bridging which are typical problems associated with the dual blade "tuning fork" design.

Being very sensitive in the lateral mode the level switch can be used for extremely light materials with densities as low as 20 grams per litre.

The strong stainless steel construction gives the Diamond Point level switch strength in the vertical direction for use with heavy materials such as cement or aggregates.

Material build-up on the container wall has no influence on the function of the Diamond Point level switch as only the tip of the vibrating blade is sensitive and not the base.

The electronic circuit of the Diamond Point level switch includes indication of power failure. Fail safe high or low is selectable.

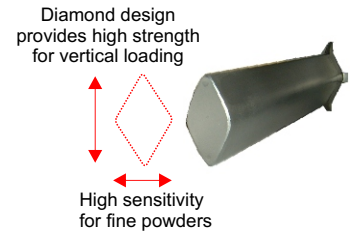

DIAMOND POINT: DP120

The standard model DP120 has an insertion length of approx. 173 mm and can be mounted to the container from top or from side for both high or low level detection. Connection to the container or vessel is made via thread 1 ½" BSP, NPT or DIN.



WELDED EXTENSION: DP130

If the application requires longer insertion length, this model offers the possibility to adapt the insertion length exactly to the length required by means of a pipe which is welded between the vibrating probe and the 1 ½" mounting socket. Maximum insertion length for DP130 is 2.0 metres. The DP130 is suitable for top mounting.



THREADED EXTENSION: DP140

The DP140 provides the flexibility of different insertion lengths up to 4.0 metres. The extension is performed by a 1" pipe with threads on both ends screwed between the vibrating probe and the 1 ½" mounting socket. As no special equipment is necessary for making the extension it is possible for the customer to obtain and mount the extension tube at the site which helps to reduce spares and save costs for transportation. The DP140 is suitable for top mounting.



FLEXIBLE CABLE EXTENSION: DP150

The DP150 can be supplied with up to 20 metres of a polyurethane sheathed, steel rope reinforced cable. The DP150 is for top mounting only. The connection to the container is made by thread 1 ½" DIN or NPT. The DP150 has the advantage of offering very long insertion lengths but also provides easy transport as it can be shipped in very compact boxes in comparison to the extension tube models DP130 and Dp140. The DP150 can be used for the detection of solids or for the detection of sediment below the liquid level.



LEVEL SWITCHES FOR SOLIDS - LOW COST

The DP600 series has a single solid stainless steel rod which is vibrated by the piezo electric element. Due to its small size it is ideal for use in small hoppers containing granular materials or pellets, like plastics, food or grain, but the circular construction of the DP600 means that it is not as sensitive to light materials. The 600 series should only be used on materials which have a bulk density greater than 90 grams per litre.

LOW COST DESIGN - DP600 AND DP660



DIAMOND POINT 100 SERIES PRODUCT SELECTOR

Code	Product				
DP1	Diamond Point Vibrating Probe				
	Code Probe Type				
	20 Standard unit DP120				
	30 Welded extension to 2m DP130				
	40 Screwed extension to 2m DP140				
	50 Flexible extension to 6m DP150				
	Code Probe Type				
	D 1.5" DIN 2999 Process connection				
	N 1.5" NPT Process connection				
	Code Cable Gland				
	-1 Single				
	-2 Double				
	Code Options				
	02-2 Remote electronics with 2.4m cable				
	-3 Sediment detection in water				
	-9 DPDT Relay				
	-19 External LED status				
	-25 High temperature version 150°C				
	,-STEX ATEX Dust approval zone 21/21/22 see pg 10				
	,-xxxx Extension length in mm for DP140/150 only				
DP1	20	D	-1	,-STEX	,-xxxx

DIAMOND POINT 600 SERIES PRODUCT SELECTOR

Code	Product		
DP600	Diamond Point Vibrating Probe		
DP660	Diamond Point Vibrating Probe for OEM		
	Code Probe Type		
	D 1" DIN 2999 Process connection		
	N 1" NPT Process connection		
	Code M16 Cable Gland		
	1 Single N/A on DP660		
	2 Double N/A on DP660		
	Code Options		
	02-2 Remote electronics with 2m cable N/A on DP660		
	25 High temperature version 150°C N/A on DP660		
	STEX ATEX Dust approval zone 20/21/22 see pg 10 N/A on DP660		
DP600	D	1	STEX

SPECIFICATION

Enclosure	DP120/130/140/150	DP600	DP660
	Die Cast Aluminium	Die Cast Aluminium	Stainless Steel
	IP66/67	IP66/67	IP66
Electrical Connection	PG13.5 (Option for 2)	M16 (Option for 2)	DIN 43650
Material Wetted Parts	Stainless Steel 1.4301	Stainless Steel 1.4301	Stainless Steel 1.4301
Process Connection	1½ DIN 2999 or 1½ NPT	1"BSPT/DIN 2999/1"NPT	1"BSPT/DIN 2999/1"NPT
Max. Vertical Load at end of Blade	1000N	80 N	80N
Max. System Pressure	10 bar	10 bar	10 bar
Max. External length	20m	-	-
System Temperature	-20°C to +80°C	-20°C to +80°C	70°C
Power Supply	20 - 250 V AC or DC	20 - 250 V AC or DC	24 V DC
Power Consumption	3 VA	2 VA	-
Output	Relay SPDT or DPDT	Relay SPDT	Relay SPDT
	250 V AC 5A	250 V AC 5A	50 V 1A
Indication (internal)	Relay – Red	Relay – Red	Relay - Red
	Power – Yellow	Power – Yellow	
Switch Delay	1 – 5 seconds	1 - 5 seconds	1 – 5 seconds
Min. Product Density	20 grams per litre	90 grams per litre	90 grams per litre
Ambient Temp. range	-20°C to +60°C	-20°C to +60°C	-20°C to +60°C

Approvals

CE Approval	EMC 890/336/EEC	-	-
Low Voltage	73/23/EEC	-	-
ATEX	Group II Cat 1/2 D For DP120, 130 & 150	Yes	Yes
Ground Level Test Facility	Optional	No	No

The instruments are ATEX classified as follows:

	Equipment Group	Category	Suitable for zones
Vibrating Probe:	II	1 D	20, 21, 22 or non-explosive atmospheres
Enclosure with electronics:	II	2 D	21, 22 or non-explosive atmospheres
Protection is provided according to EN5028-1-1-1:		- dust-tight enclosure IP6CX - limited surface temperature	
Applied standards are EN50014 and EN650928-1-1-1			

Ground Level Test Facility

Vibrating switches have the facility to be connected to a test switch or panel, mounted at the bottom of the tank or silo, which allows the high level probes to be tested without the need to climb to the top of the silo. The test is designed to be operated before each tank fill starts and the 'GLT' (ground level test) button is simply pressed on the control panel to stop the probe vibrating and test the probe electronics are working satisfactorily. Any alarms which are connected will also operate during the test to check that they are functioning correctly. The 'GLT' feature has the added benefit of helping to reduce product wastage and avoid the need for costly clean up operations from any overspill incident as well as improving the overall safety in the working environment.

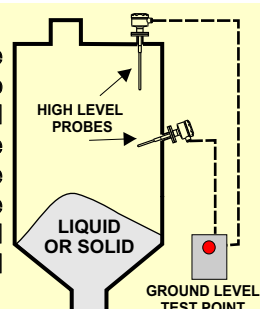

DRAWINGS

DP120

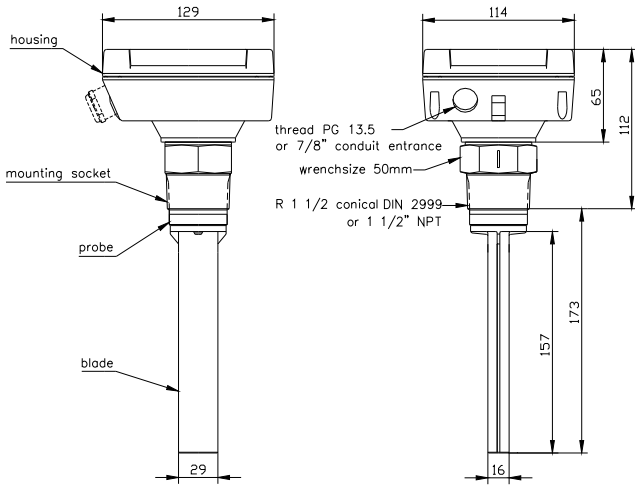

DP130

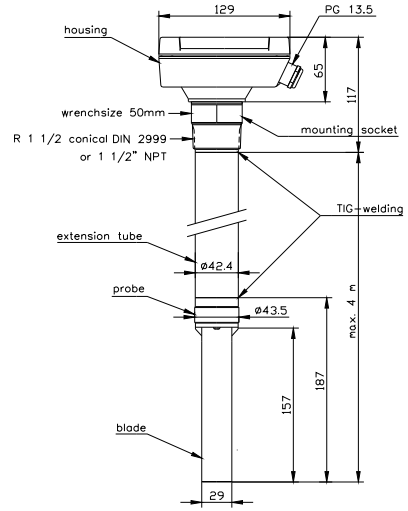

DP140

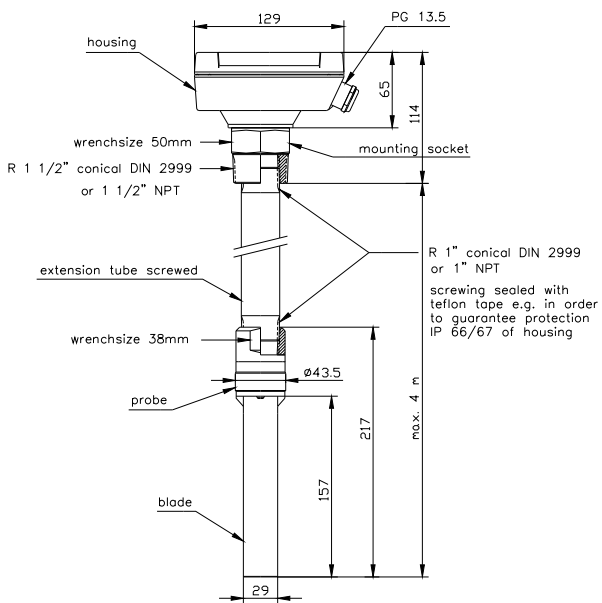

DP150

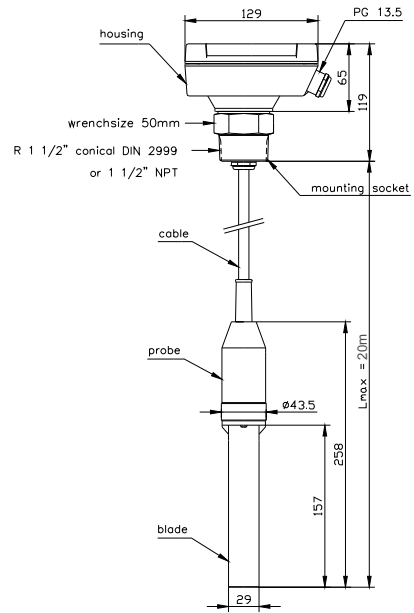

DP600

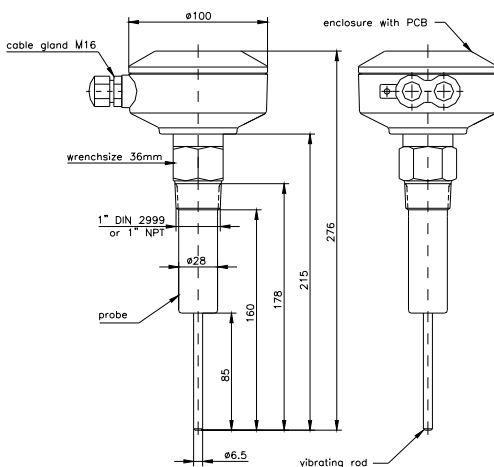

DP660

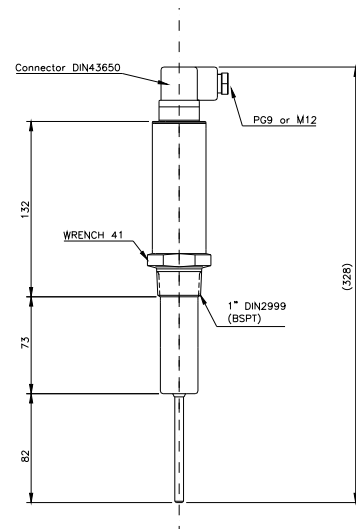

HYCONTROL LEVEL TECHNOLOGIES

Product Range For Solids :-

- (1) TDR Radar For Solids
- (2) Ultrasonic, 'Through Air'
- (2) 2 Wire Ultrasonic Transmitter
- (3) FMCW 2 Wire Radar
- (4) Continuous 'Servo' Level Indicator
- (5) FMCW 2 Wire Radar
- (6) Capacitance Level Switch
- (7) Vibrating Probe Level Switch
- (8) Rotating Paddle Level switch
- (9) Microwave Level Switch
- (10) Doppler Flow Switch

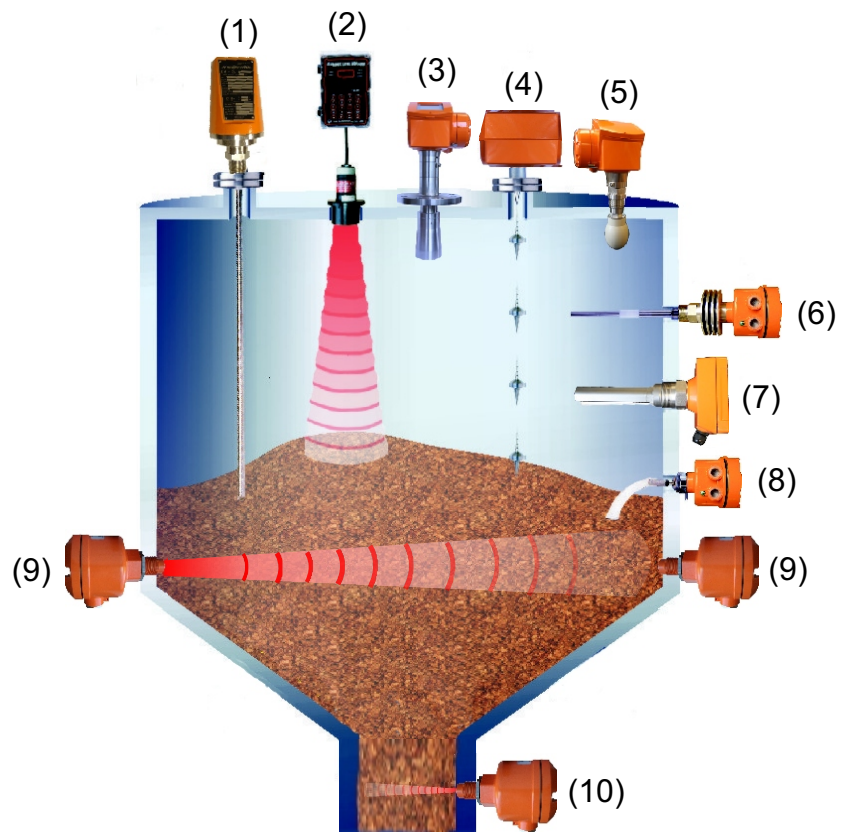

Product Range For Liquids :-

- (1) By-Pass Level Indicator With Radar
- (2) TDR Radar For Liquids
- (3) 2 Wire Ultrasonic Transmitter
- (4) FMCW 'Horn' Radar 2 Wire
- (5) Magnetic Float Switches
- (6) FMCW 2 Wire Radar
- (7) Capacitance Level Switch
- (8) RF Admittance Level Switch
- (9) Side Mounting 316 SS Float Switch
- (10) Tuning Fork Level Switch
- (11) Tuning Fork Level Switch
- (12) Ultrasonics 'Through Wall'
- (13) Mini Magnetic Float Level Switch

