

SolarWave™ SERIES



FEATURES

- High temperature butyl diaphragm
- High expansion volume factor
- Two part polyurethane, epoxy primed paint finish
- Leak free o-ring sealed air valve cap
- Comprehensive testing
- No maintenance

If you are looking for the proven performance of a GWS tank, SolarWave™ expansion tanks are the quality solution for your solar system. SolarWave™ expansion tanks are designed to control the expansion and contraction of solar thermal transfer fluids in solar heating systems. The SolarWave™ Series is intended for use on the solar liquid loop of indirect thermal transfer systems.

SolarWave™ tanks are built to the same stringent standards as PressureWave™ and Challenger™ tanks. They meet the demands of solar collector systems for both thermal expansion and contraction in order to maintain safe and efficient operating pressures within the solar liquid system.

A properly sized SolarWave™ tank will eliminate the need for recharging the system after periods of no use or in cases of extreme temperature buildup. It will eliminate relief valve release of system liquid and maintain minimum operating pressures throughout the system.

SolarWave™ Series expansion tanks have a large acceptance volume making them ideal for expansion and contraction control of solar collector systems which operate under a wide range of pressure and temperature.

SolarWave™ tanks are quality tested at several stages on the production line to insure the structural integrity of every tank. SolarWave™ tanks represent the best value for the investment and are the best quality solar expansion vessels available today.

SPECIFICATIONS SolarWave™ Series Models

Model #s		Nominal Volume		Shipping (box) Volume		Shipping (box) Weight		Dimensions					
Old Part Number	New Part Number	liter	gal	m ³	ft ³	kg	lbs	A		B		C	
		cm	inches	cm	inches	cm	inches	cm	inches	cm	inches	cm	inches
Inline Models													
SW2	SWB-2LX*	2	0.53	0.055	1.94	13.38	29.5	20.90	8.23	12.60	4.96		
SW8	SWB-8LX	8	2.1	0.016	0.57	2.20	4.85	31.30	12.32	20.20	7.95		
SW12	SWB-12LX	12	3.2	0.023	0.81	2.90	6.39	36.40	14.33	23.00	9.06		
SW18	SWB-18LX	18	4.8	0.029	1.02	3.80	8.38	36.70	14.45	27.90	10.98		
SW24	SWB-24LX	24	6	0.042	1.48	4.90	10.80	44.70	17.60	29.00	11.42		
SW35	SWB-35LX	35	9.2	0.058	2.05	6.70	14.77	48.10	18.94	31.80	12.50		
Vertical Models w/ base													
SW60V	SWB-60LV	60	14	0.102	3.60	10.80	23.81	57.60	22.68	38.90	15.31	16.00	6.30
SW80V	SWB-80LV	80	20	0.134	4.73	15.30	33.73	77.10	30.35	38.90	15.31	16.00	6.30
SW100V	SWB-100LV	100	26.4	0.168	5.93	18.20	40.12	80.40	31.65	43.00	16.90	12.90	5.08
SW130V	SWB-130LV	130	34.3	0.21	7.41	26.78	59.04	107.40	42.28	43.00	16.90	12.90	5.08
SW150V	SWB-150LV	150	40	0.21	7.41	26.78	59.04	107.40	42.28	43.00	16.90	12.90	5.08

Maximum system temperature: 130°C / 266°F

Maximum working pressure: 10 bar / 150 psi

System connection: SWB-2LX - SWB-80LV chromed carbon steel 3/4" BSP inline ; SWB-100LV - SWB-150LV stainless steel 1" BSP elbow

Factory pre-charge: 1.9 bar / 28 psi

* PWB-2LX and PWN-2LX: 12 pcs/ box

* Minor dimensional variation may occur

Above 150 liter use Challenger™ Series tanks

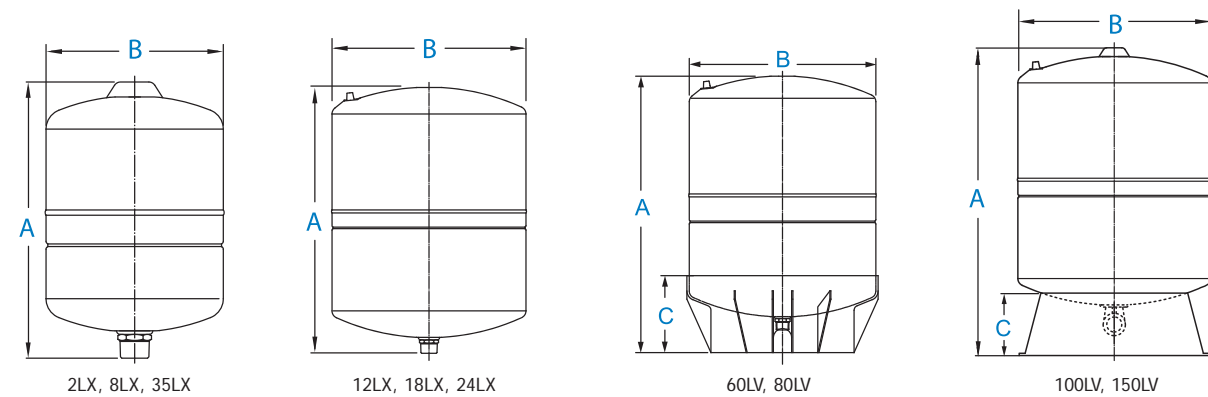

If the temperature of the solar system has the potential to rise above the evaporation point of the solar liquid a condenser chamber or coil is required between the solar collector and SolarWave™ Series expansion tank in order to control the maximum fluid temperature at the SolarWave™ tank.



ISO:9001



ACS Approved

