

EUROPE, AFRICA

9a, rue Gabriel Lippmann L-5365 Munsbach Luxembourg
Tel: +352 263 507 73 15 Efax: +1 781 658 2511

ITALY

Via Torino, 10/E 42048 Rubiera (RE) - Italy
Tel: +39 0522 626307 Fax: +39 0522 260216

MIDDLE EAST

İncirli Caddesi, 1. Yıldız Sitesi No. 101/33, Bakırköy, İstanbul, 34144, Turkey
Tel: +90 531 221 87 60

ASIA

No. 553, Jhongshan Road Cingshuei, Taichung County Taiwan, 43643
Tel: +886 4 2622 3030 Fax: +886 4 2623 3300

CHINA

Room 2910, Top Yihe International No. 10, Hong Kong Zhong Road
Qingdao, Shandong China 266071
Tel: +86-532-66888198, 66888199 Fax: +86-532-66888193.

NORTH AMERICA

P.O. Box #782 300 Pond Street Randolph, MA 02368 U.S.A.
Tel: +1 781 607 2607 Fax: +1 781 658 2511

LATIN AMERICA

P.O. Box #2107-#2050 San Pedro, Costa Rica
Tel: +506 2253 8405 Fax: +1 781 658 2511

REGISTRED OFFICE

Templar House, Don Road, St. Helier-JE1 2TR, Jersey
The Channel Islands

KOREA

#484-5, Hun Chang bldg 7F, Myeong Jang 1 Dong, Dong Rae Gu, Busan, Korea.
Tel: +82-51-526-7504 Fax: +82-51-527-7504

INDIA

1st Floor, Room No. 205, World Trade Tower, Barakhamba Lane,
Connaught Place, New Dehli - 110001
Tel: +91 40509205 Cel: +91 9810504587



GLOBAL WATER SOLUTIONS LTD.

World's Highest Quality Pressure Tanks

E-mail: info@globalwatersolutions.com www.globalwatersolutions.com

EXCELLENCE
THROUGH
QUALITY

EXCELLENCE
THROUGH
QUALITY

Contents

- 01 GWS Introduction
- 03 Product Applications
- 04 Energy Saving Solutions

POTABLE WATER TANKS

- 05 PressureWave™
- 07 HydroGuard™
- 09 M-Inox™
- 11 Max™ & UltraMax™
- 13 Challenger™
- 15 C2-Lite CAD™
- 17 C2-Lite UT™
- 19 FlowThru™
- 21 SuperFlow™
- 23 RoWave™
- 25 ThermoWave™

NON-POTABLE WATER TANKS

- 27 HeatWave™
- 29 SolarWave™

OTHER PRODUCTS/ACCESSORIES

- 31 SpringTech™
- 35 PumpWave™
- 36 Accesories

GLOBAL WATER SOLUTIONS LTD. OFFERS A COMPREHENSIVE AND WIDE RANGE OF PRESSURE VESSELS

for heating, thermal, pressure booster, water hammer,
reverse osmosis and water well applications.

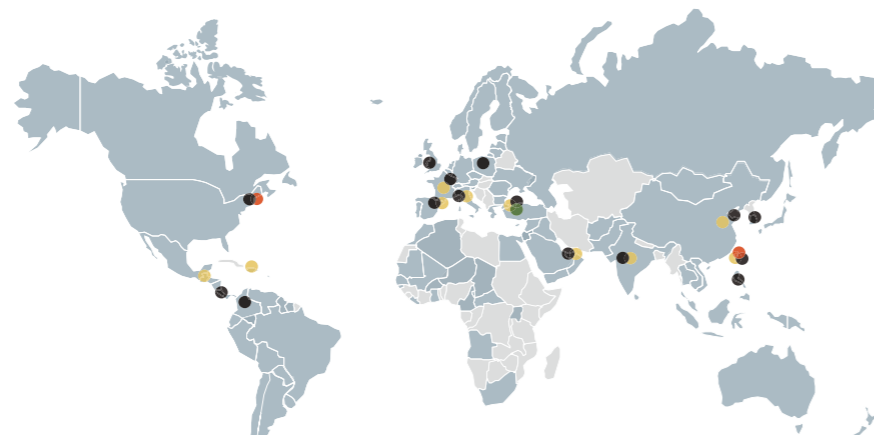

● Warehouses ● GWS Offices ● GWS Manufacturing Facilities ● Contract Manufacturing

GLOBAL WATER SOLUTIONS LTD. products are available in 100 countries worldwide covering Central and South America, Europe, The Middle East, Africa, Australia, New Zealand and Asia. GWS is a member of the Swan Group.

GLOBAL WATER SOLUTIONS LTD.'S

unique product offering includes both its patent protected CAD-2 diaphragm tanks as well as its line of single diaphragm tanks with a patented water connection and now also a series with replaceable tiered membrane design. This combination provides GLOBAL WATER SOLUTIONS LTD. customers with flexibility in selecting products for specific applications. All our products undergo a series of tests to insure the excellent quality. Beyond that, we offer our customers an extensive warranty.



GLOBAL WATER SOLUTIONS LTD. is also on the forefront of international regulatory issues with approvals from WRAS, NSF, PED, ACS, EVRAZES and other country specific approvals.



Product Applications

Our wide product range offers a full-line of pressure vessels for different applications. pressure vessels in sizes from 0.16-10,000 liters and in 10, 16 and 25 bar pressure ratings are available to accommodate all your requirements

- **PressureWave™, Challenger™, SuperFlow™ & C2Lite™, FlowThru™ Series**
Booster systems, water well systems, sprinklers, HVAC, thermal expansion, irrigation systems, water hammer arresting.
- **HeatWave™ Series**
Hydronic expansion, boiler systems.
- **SolarWave™ Series**
Closed loop solar systems, solar hot water expansion.
- **ThermoWave™ Series**
Potable Water Heating Applications.
- **RoWave™ Series**
Reverse Osmosis (RO) purified drinking water systems.
- **Ultra(Max)™ Series**
High pressure applications (16 and 25 bar).
- **M-Inox™ Series**
Stainless steel tanks ideally suited for special demands and environments.
- **HydroGuard™ Series**
Water hammer arresting, plumbing applications.

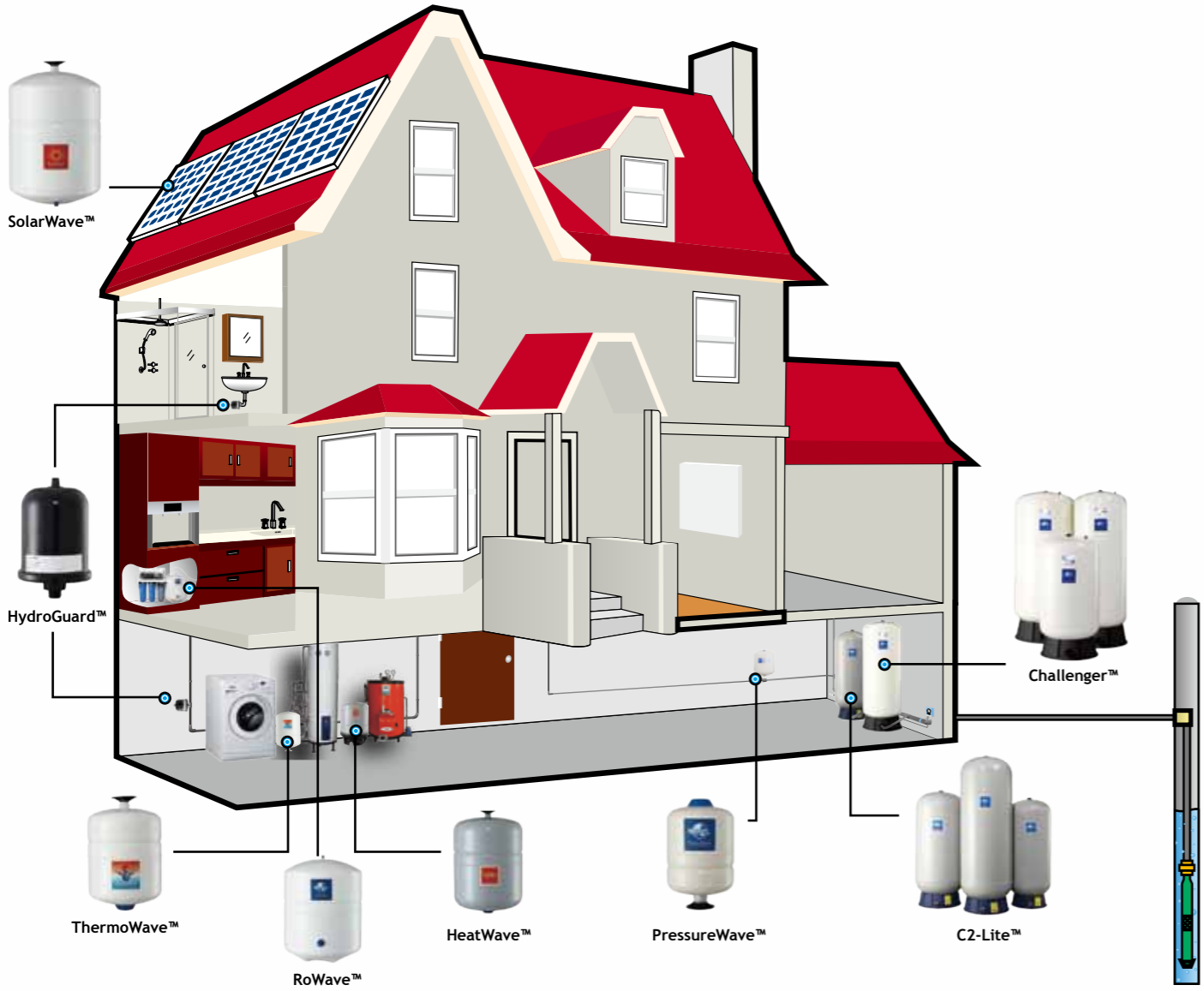

Energy Saving Solutions

Upsize your pressure tank and get the following benefits:

- Substantially reduce electric power consumption by reducing small draw off pump starts, i.e., evaporative coolers, toilet flushes, leaks, drip irrigation, etc.
- Extend pump life by dramatically reducing wear on moving parts
- Protect against heat expansion damage to pump bodies
- Reduce noise from unnecessary pump starts
- Eliminate motor burn outs and low flow cycling
- Eliminate pump body failures due to water hammer



Minimize your environmental footprint.



All this with a tank that...
 ... requires NO maintenance (does not require regular air charge checks) and
 ... has the longest warranty for guaranteed reliability.

PressureWave™ SERIES



FEATURES

- Single diaphragm design
- NSF Standard 61, CE/PED, WRAS, ACS, ISO:9001, Gost, Evrazes approved
- Patented stainless steel water connection
- Virgin polypropylene liner
- Two part polyurethane, epoxy primed paint finish
- Leak free, o-ring sealed air valve cap
- Comprehensive testing
- No maintenance

PressureWave™ tanks are ideally suited for a wide range of applications, including booster systems, thermal expansion, irrigation systems, and hydraulic hammer arresting.

The PressureWave™ Series is constructed of a virgin polypropylene liner combined with an FDA approved high grade butyl diaphragm. This is held against the wall of the tank with a steel clench ring. The brass air valve, sealed by a threaded o-ring valve cap, prevents air leaks. Water enters the tank through a patented stainless steel water connection. The diaphragm and liner are both reinforced in specific wear areas for longer life. All internal parts including the air valve are rounded to prevent piercing of the diaphragm in extreme conditions. The water connection uniquely provides a dual water/air seal ensuring a complete leak free and maintenance free pressure vessel.

On the exterior the almond colored two-part polyurethane paint finish over an epoxy undercoating provides hundreds of hours of UV and salt spray protection.

PressureWave™ tanks are quality tested at several stages on the production line to insure the structural integrity of every tank.

PressureWave™ tanks represent the best value for the investment and are the best quality pressure vessels available today.

SPECIFICATIONS PressureWave™ Series Models

BSP		NPT		Nominal Volume		Shipping (box) Volume		Shipping (box) Weight		Dimensions					
Old Part Number	New Part Number	Old Part Number	New Part Number	liter	gal	m ³	ft ³	kg	lbs	A		B		C	
										cm	inches	cm	inches	cm	inches
PWB2	PWB-2LX	PWN2	PWN-2LX	2	0.5	0.06	2.12	13.60	29.98	20.90	8.23	12.60	4.96		
PWB4	PWB-4LX	PWN4	PWN-4LX	4	1.1	0.01	0.35	1.71	3.77	26.10	10.28	16.20	6.38		
PWB8	PWB-8LX	PWN8	PWN-8LX	8	2.1	0.014	0.49	2.40	5.29	31.30	33.60	20.20	7.95		
PWB12	PWB-12LX	PWN12	PWN-12LX	12	3.2	0.023	0.81	3.10	6.83	36.70	14.45	23.00	9.06		
PWB18	PWB-18LX	PWN18	PWN-18LX	18	4.8	0.03	1.06	4.10	9.04	36.70	14.45	27.90	10.98		
PWB24	PWB24LX	PWN24	PWN-24LX	24	6.3	0.042	1.48	5.00	11.00	44.70	17.60	29.00	11.42		
PWB35	PWB-35LX	PWN35	PWN-35LX	35	9.3	0.056	1.98	7.00	15.43	48.10	18.90	31.80	12.52		
Horizontal Models															
PWB8H	PWB-8LH	PWN8H	PWN-8LH	8	2.1	0.013	0.46	2.46	5.42	31.30	12.32	23.20	9.13	11.60	4.57
PWB12H	PWB-12LH	PWN12H	PWN-12LH	12	3.2	0.024	0.85	3.25	7.17	36.70	14.45	26.00	10.24	13.00	5.12
PWB20H	PWB-20LH	PWN20H	PWN-20LH	20	5.3	0.04	1.41	5.00	11.02	44.70	17.60	29.40	11.57	14.70	5.79
PWB24H	PWB-24LH	PWN24H	PWN-24LH	24	6.3	0.047	1.65	5.90	13.01	44.70	17.60	32.10	12.64	16.10	6.34
PWB35H	PWB-35LH	PWN35H	PWN-35LH	35	9.3	0.061	2.15	8.20	18.08	48.10	18.94	35.30	13.90	17.90	7.05
PWB60H	PWB-60LH	PWN60H	PWN-60LH	60	15.9	0.09	3.18	11.40	25.13	53.00	20.87	42.40	16.69	21.50	8.46
PWB80H	PWB-80LH	PWN80H	PWN-80LH	80	21.1	0.13	4.59	16.10	35.49	72.60	28.58	42.40	16.69	21.50	8.46
PWB100H	PWB-100LH	PWN100H	PWN-100LH	100	26.4	0.16	5.65	19.20	42.33	72.00	28.35	47.50	18.70	24.50	9.65
Vertical Models w/ base															
PWB35V	PWB-35LV	PWN35V	PWN-35LV	35	9.3	0.063	2.22	7.80	17.20	55.50	21.85	31.80	12.52	12.00	4.72
PWB60V	PWB-60LV	PWN60V	PWN-60LV	60	15.9	0.098	3.46	11.80	26.01	62.00	24.41	38.90	15.31	12.70	5.00
PWB80V	PWB-80LV	PWN80V	PWN-80LV	80	21.1	0.13	4.59	16.20	35.71	81.50	32.09	38.90	15.31	12.70	5.00
PWB100V	PWB-100LV	PWN100V	PWN-100LV	100	26.4	0.16	5.65	19.10	42.11	80.40	31.65	43.00	16.93	12.90	5.08
PWB130V	PWB-130LV	PWN130V	PWN-130LV	130	34.3	0.21	7.42	26.70	58.86	81.80	32.20	53.00	20.87	13.85	5.45
PWB150V	PWB-150LV	PWN150V	PWN-150LV	150	40.0	0.28	9.89	31.4	69.23	92.40	36.38	53.00	20.87	13.85	5.45

Standard System Connection: 1"
 All connections are stainless steel unless stated otherwise. Tank precharge: 1.9 bar / 28 psi
 Maximum Working Pressure: 10 bar / 150 psi Maximum Working Temperature: 90°C / 194°F
 Available in 16 and 25 bar as Max™ and UltraMax™ Series
 Available in smaller sizes as HydroGuard™ Series
 PWB-2LX and PWN-2LX: 12 pcs/ box

* Technical variance may occur

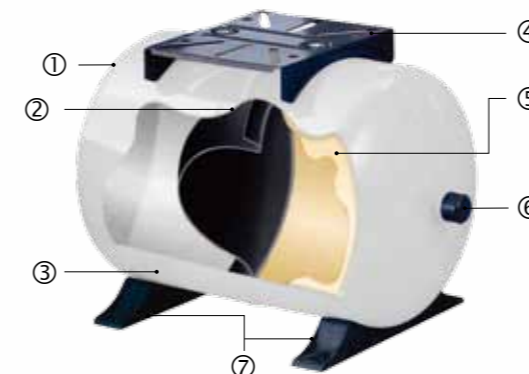

- ① Leak free, o-ring sealed air valve cap
- ② Single diaphragm design
- ③ Two part polyurethane, epoxy primed paint finish
- ④ Nylon Plastic Pump Stand
- ⑤ Virgin polypropylene liner
- ⑥ Patented stainless steel water connection
- ⑦ Plastic Tank Feet

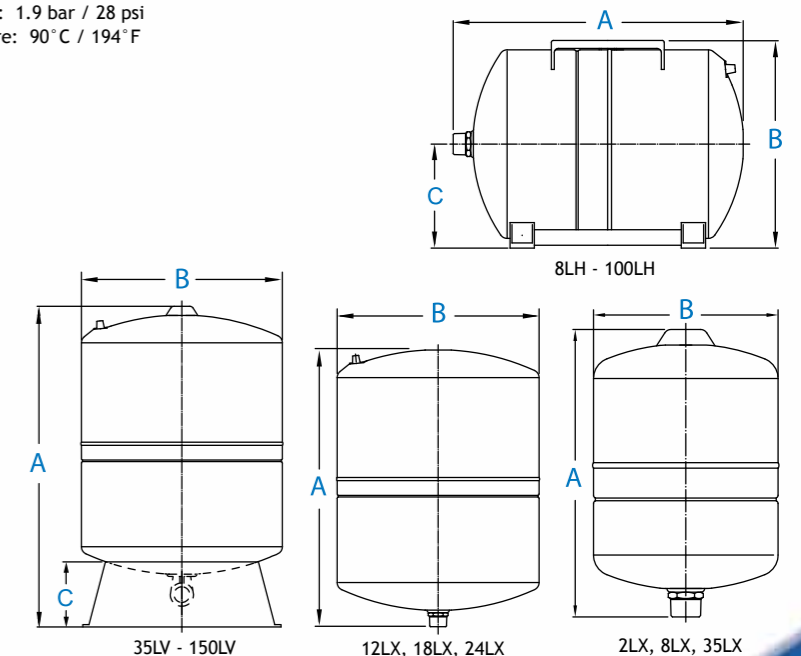

ISO:9001



ACS Approved



HydroGuard™ SERIES



FEATURES

- Single diaphragm design
- Patented stainless steel or Noryl water connection
- Two part polyurethane, epoxy primed paint finish
- Leak free, o-ring sealed air valve cap
- Comprehensive testing
- No maintenance

HydroGuard™ shock arrestors are specially designed for use in hydraulic hammer arresting applications.

HydroGuard™ shock arrestors are built to reduce or eliminate hydraulic shock, otherwise known as water hammer. They do this by absorbing pressure surges within water or other fluids that are suddenly stopped or forced in other directions by fast closing valves. HydroGuard™ shock arrestors are best used at the point of shock and should be installed as close to the valve or piping where the shock originates from.

HydroGuard™ shock arrestors are designed with the latest diaphragm technology. A high grade chlorobutyl diaphragm is sealed inside the vessel creating a barrier between fluid and air chambers. The air chamber acts as a cushion which compresses when system pressure suddenly increases or surges as a result of hydraulic shock. HydroGuard™ shock arrestors are quality tested at several stages along the production line in ensure the structural integrity of every tank.

HydroGuard™ shock arrestors represent the best value for the investment and are the best quality shock arrestors available today.

SPECIFICATIONS

HydroGuard™ Series Models

BSP		NPT		Connection	Nominal Volume		Shipping (box) Volume		Pieces per box	Shipping (box) Weight		Dimensions			
Old Part Number	New Part Number	Old Part Number	New Part Number		liter	gal	m ³	ft ³		kg	lbs	A		B	
											cm	inch-es	cm	inch-es	
PWSA1SS	HGNSA-0.16LX	PWSA1SS	HGNSA-0.16LX	1/2" SS	0.16	0.04	0.05	1.67	24	10.00	22.05	10.10	3.98	8.50	3.40
PWSA3	HGBSC-0.3LX	PWSA3	HGBSC-0.3LX	1/2" Noryl	0.3	0.08	0.05	1.67	40	15.82	34.88	10.00	3.94	9.70	3.80
PWSA5	HGBSC-0.5LX	PWSA5	HGBSC-0.5LX	1/2" Noryl	0.5	0.13	0.06	1.97	24	14.50	33.60	13.50	5.31	11.30	4.45
PWSA6	HGBSD-0.6LX	PWSA6	HGBSD-0.6LX	1/2" Noryl	0.6	0.16	0.04	1.24	20	11.68	25.75	13.78	5.43	11.30	4.45
PWSA10SS	HGPSO-1LX	PWSA10SS	HGPSO-1LX	1/2" Noryl	1	0.26	0.05	1.67	15	11.77	25.95	14.35	5.65	13.60	5.35
PWB1	HGPSR-1LX	PWN1	HGPSR-1LX	1/2" SS	1	0.26	0.07	2.42	20	17.90	39.46	19.70	7.76	12.00	4.72
PWSA20SS	HGPSO-2LX	PWSA20SS	HGPSO-2LX	1/2" Noryl	2	0.5	0.07	2.42	12	15.87	34.99	16.30	6.42	17.00	6.69
PWB2	HGBPA-2LX	PWN2	HGNPA-2LX	1/2" SS	2	0.5	0.06	1.97	12	13.62	30.03	20.80	8.19	12.60	5.00
PWB4	HGBPA-4LX	PWN4	HGNPA-4LX	1/2" SS	4	1.1	0.01	0.28	1	1.71	3.77	26.10	10.28	16.20	6.40

*Variations available, ask your sales person
 Maximum Working Pressure: 10 bar / 150 psi
 Maximum Working Temperature: 90°C / 194°F

* Technical variance may occur

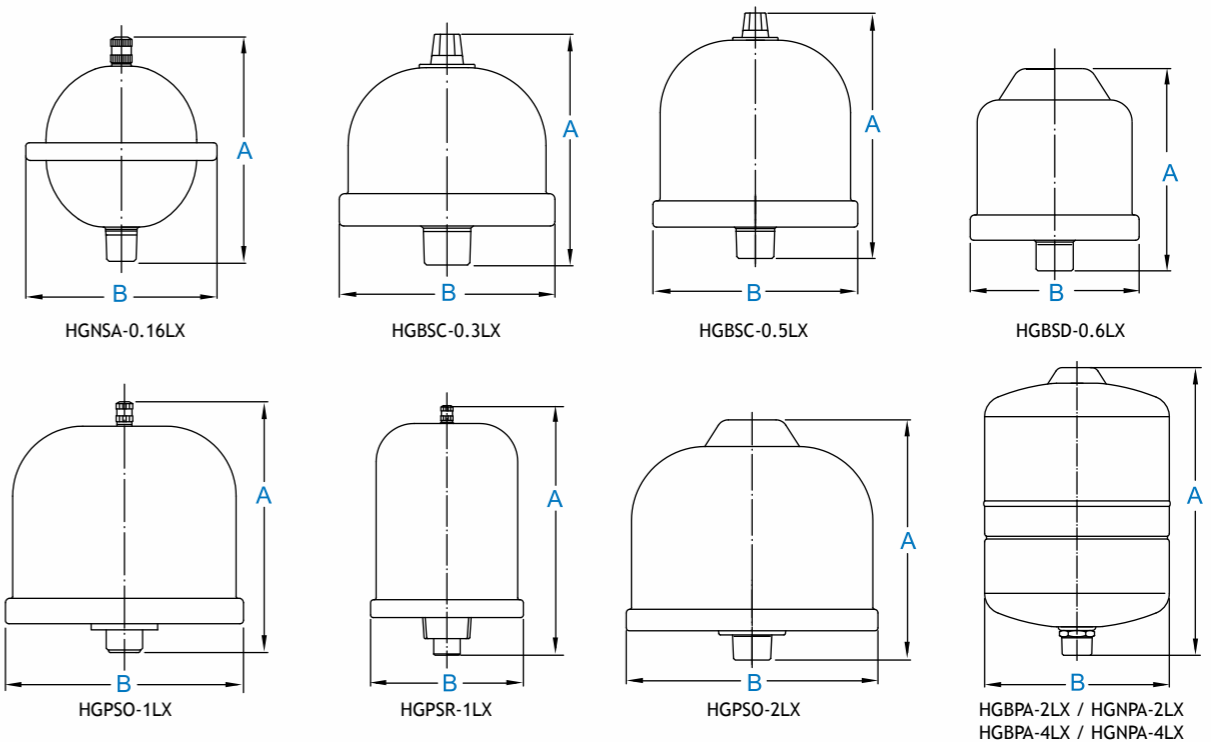

ISO:9001 CE



M-Inox™ SERIES



FEATURES

- High Grade Stainless Steel Tank construction
- Single diaphragm design
- NSF Standard 61, CE/PED, WRAS, ACS, ISO:9001, Gost, Evrazes approved
- Patented stainless steel water connection
- Virgin polypropylene liner
- Leak free, o-ring sealed air valve cap
- Comprehensive testing
- No maintenance

M-Inox™ stainless steel tanks are ideally suited for special demands and environments.

The M-Inox™ Series is constructed of a virgin polypropylene liner combined with an FDA approved high grade butyl diaphragm. This is held against the wall of the tank with a steel clench ring. The brass air valve, sealed by a threaded o-ring valve cap, prevents air leaks. Water enters the tank through a patented stainless steel water connection. The diaphragm and liner are both reinforced in specific wear areas for longer life. All internal parts including the air valve are rounded to prevent piercing of the diaphragm in extreme conditions. The water connection uniquely provides a dual water/air seal ensuring a complete leak free and maintenance free pressure vessel.

M-Inox™ tanks are quality tested at several stages on the production line to insure the structural integrity of every tank.

M-Inox™ tanks represent the best value for the investment and are the best quality stainless steel pressure vessels available today.

SPECIFICATIONS

M-Inox™ Series Models

BSP		NPT		Connec- tion	Nominal Volume		Shipping (box) Volume		Shipping (box) Weight		Dimensions						
Old Part Number	New Part Number	Old Part Number	New Part Number		BSP / NPT SS InLine	liter	gal	m ³	ft ³	kg	lbs	A		B		C	
											cm	inches	cm	inches	cm	inches	
PWB8 SS	MIB-8LX	PWN8 SS	MIN-8LX	1"	8	2.1	0.014	0.49	2.35	5.18	31.30	12.32	20.20	7.95			
PWB18 SS	MIB-18LX	PWN18 SS	MIN-18LX	1"	18	4.8	0.03	1.06	4.11	9.06	38.40	15.12	27.90	11.20			
PWB18H SS	MIB-18LH	PWN18H SS	MIN-18LH	1"	18	4.8	0.048	1.70	4.82	10.63	38.40	15.12	30.90	12.17	15.50	6.10	

* Technical variance may occur

Tank precharge: 1.9 bar / 28 psi

Maximum Working Pressure: 10 bar / 150 psi Maximum Working Temperature: 90°C / 194°F



- ① Stainless Steel Tank
- ② Water Chamber
- ③ Patented Stainless Steel Water Connection
- ④ Leak-Free O-ring Sealed Air Valve Cap
- ⑤ High Grade Butyl Diaphragm
- ⑥ Virgin Polypropylene Liner

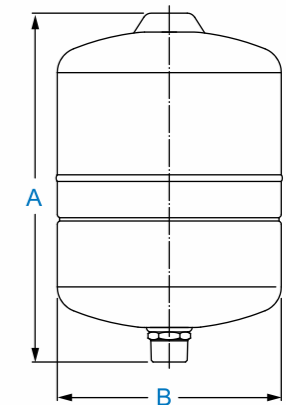

8LX, 18LX

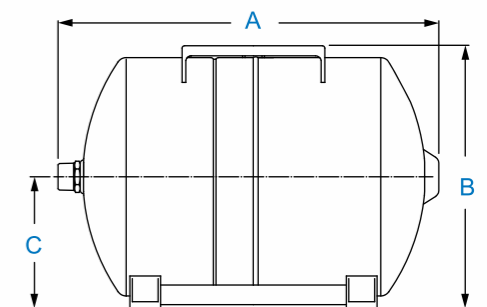

18LH

ISO:9001



ACS
Approved



Max™ & UltraMax™ SERIES



SPECIFICATIONS Max™ Series Models (16 bar)

BSP		NPT		Connection	Nominal Volume		Shipping (box) Volume		Shipping (box) Weight		Dimensions					
Old Part Number	New Part Number	Old Part Number	New Part Number		BSP / NPT SS Inline	liter	gal	m³	ft³	kg	lbs	A		B		C
PWB2 16	MXB-2LX	PWN2 16	MXN-2LX	1"	2	0.5	0.06	2.12	0.80	1.76	20.90	8.23	12.60	4.96		
PWB8 16	MXB-8LX	PWN8 16	MXN-8LX	1"	8	2.1	0.014	0.49	2.43	5.36	31.30	12.32	20.20	7.95		
PWB12 16	MXB-12LX	PWN12 16	MXN-12LX	1"	12	3.2	0.023	0.81	3.20	7.05	33.70	14.37	23.00	9.06		
PWB18 16	MXB-18LX	PWN18 16	MXN-18LX	1"	18	4.7	0.03	1.06	4.76	10.49	36.70	14.45	27.90	10.98		
PWB24 16	MXB-24LX	PWN24 16	MXN-24LX	1"	24	6.3	0.042	1.48	5.95	13.12	44.70	17.60	29.00	11.42		
PWB35 16	MXB-35LX	PWN35 16	MXN-35LX	1"	35	9.2	0.06	1.95	8.57	18.89	48.10	18.90	31.80	12.52		

Vertical Models w/ base																
Old Part Number	New Part Number	Old Part Number	New Part Number	BSP / NPT SS Elbow	liter	gal	m³	ft³	kg	lbs	cm	inches	cm	inches	cm	inches
PWB60V 16	MXB-60LV	PWN60V 16	MXN-60LV	1"	60	15.8	0.098	3.46	15.1	33.33	62.00	24.41	39.00	15.35	12.70	5.00
PWB80V 16	MXB-80LV	PWN80V 16	MXN-80LV	1"	80	21.0	0.13	4.59	20.7	45.61	81.50	32.09	39.00	15.35	12.70	5.00
PWB100V 16	MXB-100LV	PWN100V 16	MXN-100LV	1"	100	26.3	0.16	5.65	22.2	48.92	80.40	31.65	43.10	16.97	12.90	5.08

* Volume and weight for MXB-2LX and MXN-2LX mentioned for a box with 12 pieces.
 All connections are made of stainless steel. Tank precharge: 4.0 bar / 58 psi
 Maximum working pressure: 16 bar / 232 psi. Maximum working temperature: 90°C / 194°F

* Technical variance may occur

FEATURES

- Suitable for many high-pressure applications
- Super thick steel construction
- Patented stainless steel water connection
- Virgin polypropylene liner
- Two part polyurethane, epoxy primed paint finish
- Leak free, o-ring sealed air valve cap
- Comprehensive testing
- No maintenance
- Single diaphragm design
- Available in 16 bar and 25 bar maximum pressure

SPECIFICATIONS UltraMax™ Series Models (25 bar)

BSP		NPT		Connection	Nominal Volume		Shipping (box) Volume		Shipping (box) Weight		Dimensions					
Old Part Number	New Part Number	Old Part Number	New Part Number		BSP / NPT SS Inline	liter	gal	m³	ft³	kg	lbs	A		B		C
PWB8 25	UMB-8LX	PWN8 25	UMN-8LX	0.014	0.49	3.49	7.69	0.48	3.49	7.67	31.30	12.32	20.30	7.99	-	-
PWB24 25	UMB-24LX	PWN24 25	UMN-24LX	0.042	1.48	8.74	19.27	1.48	8.74	19.27	44.70	17.60	29.30	11.54	-	-

All connections are made of stainless steel. Tank precharge: 4.0 bar / 58 psi
 Maximum working pressure: 25 bar / 362 psi. Maximum working temperature: 90°C / 194°F

* Technical variance may occur

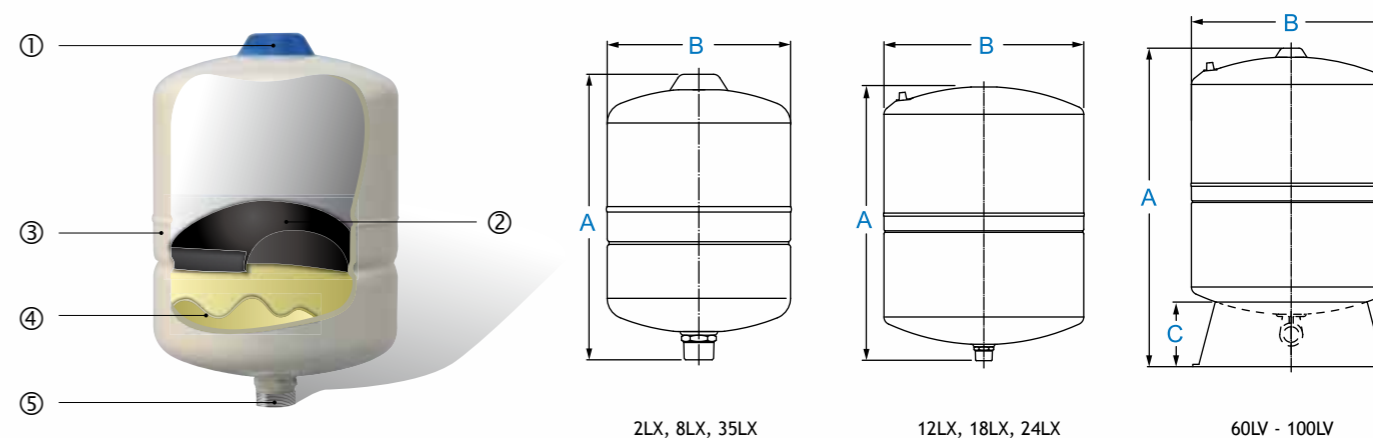

- ① Leak free, o-ring sealed air valve cap
- ② Single diaphragm design
- ③ Two part polyurethane, epoxy primed paint finish
- ④ Virgin polypropylene liner
- ⑤ Patented stainless steel water connection

ISO:9001 CE ACS Approved



Challenger™ SERIES



FEATURES

- Patented CAD-2 diaphragm technology
- NSF Standard 61, CE/PED, WRAS, ACS, ISO-9001, Gost, Evrazes approved
- Stainless steel water connection
- Condensation reducing design
- Two part polyurethane, epoxy primed paint finish
- Leak free air valve cap sealed with closed cell foam
- Comprehensive testing
- No maintenance

Challenger™ tanks are ideally suited for a wide range of applications, including booster systems, thermal expansion, heating expansion, irrigation systems, and hydraulic hammer arresting.

Water Chamber, Patented Controlled Action Design:
Efficient and cost effective, Challenger™ tanks are designed with a patented controlled action CAD-2 diaphragm assembly. It features a chlorine resistant 100% butyl diaphragm with a precision molded copolymer polypropylene liner for superior air and water separation. The CAD-2 diaphragm assembly is clenched together with a positive lock internal clench ring which contains drawdown water in a pre-charged air atmosphere, thus providing separation between the diaphragm and tank wall. This “air buffer” design means few problems with condensation. Constructed with an FDA approved high grade butyl, the diaphragm assembly seals water in a true non-corrosive chamber.

On the exterior, the almond colored two part polyurethane paint finish over an epoxy undercoating provides hundreds of hours of UV and salt spray protection.

The air chamber is sealed with a fixed o-ring and closed cell foam and will provide many years of leak free and service free life. Challenger™ tanks are quality tested at several stages on the production line to insure the structural integrity of every tank. Challenger™ tanks are the best steel pressure vessels in the market today and represent the best value for the investment.

SPECIFICATIONS Challenger™ Series Models

BSP		NPT		Nominal Volume		Shipping (box) Volume		Shipping (box) Weight		Dimensions							
Old Part Number	New Part Number	Old Part Number	New Part Number	liter	gal	m ³	ft ³	kg	lbs	A		B		C		D	
										cm	inches	cm	inches	cm	inches	cm	inches
GC60	GCB-60LV	GW15	GCN-15GV	60	15	0.10	3.65	12.25	27.0	56.52	22.25	40.68	16.02	4.71	1.85	36.22	14.26
GC80	GCB-80LV	GW120	GCN-20GV	80	20	0.13	4.74	15.20	33.5	74.54	29.35	40.68	16.02	4.71	1.85	36.22	14.26
GC100	GCB-100LV	GW125	GCN-25GV	100	25	0.16	5.68	19.52	43.0	88.83	34.97	40.68	16.02	4.71	1.85	36.22	14.26
GC130	GCB-130LV	GW135	GCN-35GV	130	35	0.20	7.08	24.74	54.5	110.09	43.34	40.68	16.02	4.71	1.85	36.22	14.26
GC200	GCB-200LV	GW150	GCN-50GV	200	50	0.31	10.88	38.10	84.0	104.14	41.00	53.42	21.03	5.70	2.24	44.63	17.57
GC240	GCB-250LV	GW160	GCN-60GV	240	60	0.37	13.18	43.81	96.5	122.37	48.18	53.42	21.03	5.70	2.24	44.63	17.57
GC310	GCB-300LV	GW180	GCN-80GV	310	80	0.46	16.25	52.89	116.5	151.07	59.48	53.41	21.03	5.70	2.24	44.63	17.57
GC450	GCB-450LV	GW120	GCN-120GV	450	120	0.74	26.14	80.81	178.0	153.90	60.59	66.06	26.01	5.70	2.24	54.23	21.35

System Connection:

- Models GCB-60LV - GCB-130LV: 1" BSP stainless steel elbow
- Models GCB-200LV - GCB-450LV: 1 1/4" BSP stainless steel elbow
- Models GCN-15GV - GCN-35GV: 1" NPT stainless steel elbow
- Models GCN-50GV - GCN-120GV: 1 1/4" NPT stainless steel elbow

* Technical variance may occur

Please refer to tank packaging for correct factory set pre-charge information.

Maximum working temperature 90° C / 194° F
Maximum working pressure 10 bar / 150 psi

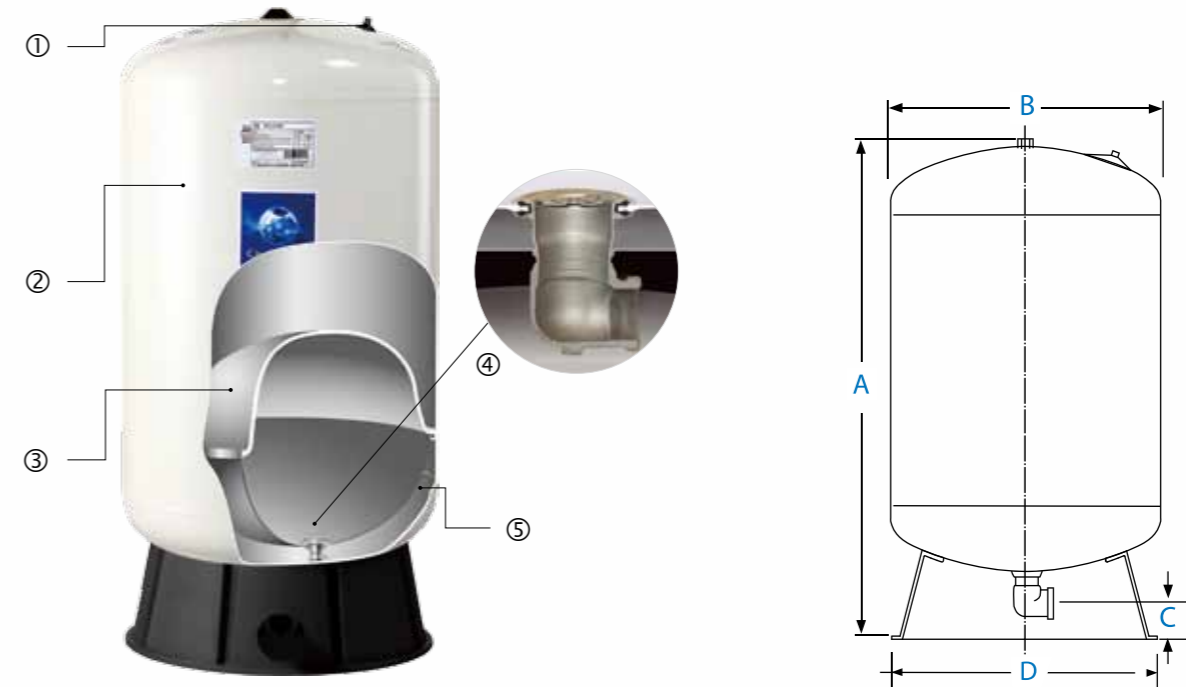

- ① Leak-Free, O-ring sealed air valve cap
- ② Two-part polyurethane / epoxy primed paint finish
- ③ Patented CAD-2 diaphragm design
- ④ Stainless steel water connection
- ⑤ Condensation reducing design

ISO:9001



ACS Approved



C2 Lite CAD™ SERIES



FEATURES

- Patented CAD-2 diaphragm technology
- Unique 3 piece construction
- Reinforced Plastic Connection
- Durable continuous strand fiberglass sealed with epoxy resin
- NSF Standard 61, CE/PED, WRAS, ACS, ISO:9001 , Evrazes approved
- Rugged copolymer polypropylene base
- Quality brass air stem with o-ring seal
- No sweat design
- Comprehensive testing
- No maintenance

If you are looking for the proven performance of a GWS steel tank in a lightweight composite design, C2-Lite CAD™ series is the answer. Efficient and cost effective, C2-Lite CAD™ tanks are designed with the patented controlled action diaphragm design of GWS Challenger™ tanks. Unlike other composite tanks that hide tired old bag technology in a plastic shell, the patented CAD-2 diaphragm design is stronger and will not crease and wear out. It features a chlorine resistant 100% butyl diaphragm with a precision molded copolymer polypropylene liner for superior air and water separation. This patented design allows each size tank to have a properly sized water chamber matched to the drawdown performance of that tank. C2-Lite CAD™ tanks are easy to install, weather resistant and engineered to withstand even extreme environmental conditions. When it comes to performance and durability, the GWS C2-Lite CAD™ design cannot be beat.

C2-Lite CAD™ tanks are quality tested at several stages on the production line to insure the structural integrity of every tank. C2-Lite CAD™ tanks represent the best value for the investment and are the best quality composite vessels available today.

SPECIFICATIONS C2-Lite CAD™ Series Models

BSP		NPT		Nominal Volume		Shipping (box) Volume		Shipping (box) Weight		Dimensions							
Old Part Number	New Part Number	Old Part Number	New Part Number	liter	gal	m ³	ft ³	kg	lbs	A		B		C		D	
										cm	inches	cm	inches	cm	inches	cm	inches
C2B-60	C2B-60LV	C2N15	C2N-15GV	60	15	0.13	4.44	8.60	19.0	64.90	25.60	4.50	1.80	41.80	16.60	23.88	9.40
C2B-80	C2B-80LV	C2N20	C2N-20GV	80	20	0.16	5.79	10.90	24.0	85.20	34.06	4.50	1.80	41.80	16.60	23.88	9.40
C2B-100	C2B-100LV	C2N25	C2N-25GV	100	25	0.19	6.66	12.70	28.0	96.70	38.60	4.50	1.80	41.80	16.60	23.88	9.40
C2B-130	C2B-130LV	C2N35	C2N-35GV	130	35	0.23	8.26	15.20	33.5	122.70	48.88	4.50	1.80	41.80	16.60	23.88	9.40
C2B-200	C2B-200LV	C2N50	C2N-50GV	200	50	0.35	12.24	20.20	44.5	109.80	43.30	5.70	2.30	54.20	21.50	30.23	11.90
C2B-250	C2B-250LV	C2N65	C2N-65GV	250	65	0.41	14.50	24.97	55.0	130.30	51.30	5.70	2.30	54.20	21.50	30.23	11.90
C2B-300	C2B-300LV	C2N80	C2N-80GV	300	80	0.52	18.23	28.15	62.0	164.40	64.70	5.70	2.30	54.20	21.50	30.23	11.90
C2B-350	C2B-350LV	C2N90	C2N-90GV	350	90	0.59	20.66	33.14	73.0	144.80	57.00	5.70	2.30	61.40	24.30	34.04	13.40
C2B-450	C2B-450LV	C2N120	C2N-120GV	450	120	0.74	26.06	36.32	80.0	183.10	72.10	5.70	2.30	61.40	24.30	34.04	13.40

Max. Working Pressure 8.6 bar / 125 psi
 Max. Working Temperature 49°C / 120°F
 Connection C2B-60LV - C2B-130LV 1" BSP

C2B-200LV-C2B-450LV 1 1/4" BSP
 C2N-15GV - C2N-35GV 1" NPT C2N-50GV - C2N-120GV 1 1/4" NPT
 Please refer to tank packaging for correct factory set pre-charge information.

* Technical variance may occur



- ① Precision injection molded domes
- ② High-tech spin welding process
- ③ Patented CAD-2 controlled action diaphragm design
- ④ Durable continuous strand fiberglass sealed with epoxy resin
- ⑤ Reinforced Plastic Connection
- ⑥ Rugged base

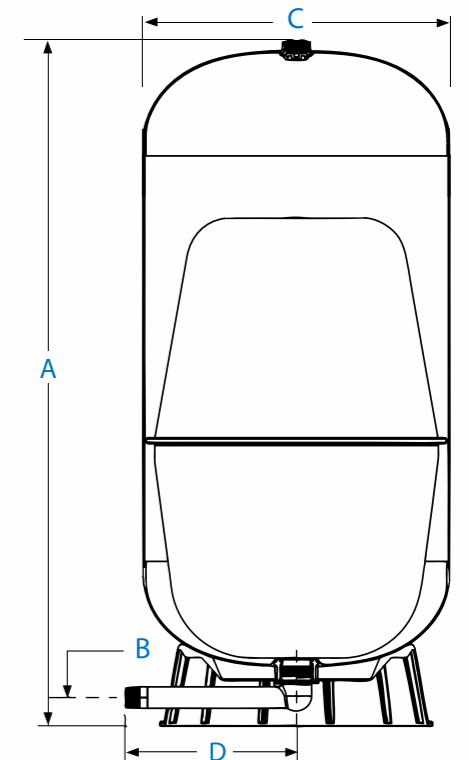

ISO:9001



ACS Approved



C2 Lite UT™ SERIES



FEATURES

- Precision injection molded domes for uniform wall thickness and consistent engineered dome profiles
- Reinforced with durable continuous strand fibreglass and sealed with weather-resistant epoxy resin
- Rugged base engineered to withstand maximum loads and extreme environmental conditions
- Durable, removable schedule PVC water connection that can be accessorized
- Lightweight, non-corrosive, scratch-resistant construction
- NSF Standard 61, CE/PED, WRAS, ACS, ISO:9001, Evrazes approved
- Comprehensive testing
- No maintenance

C2-Lite UT™ tanks are ideally suited for a wide range of applications, including commercial and residential storage, contact, hydropneumatic and degassing applications.

With C2-Lite UT™ series GWS has engineered a line of lightweight composite utility tanks designed to stand up to years of tough service in the field.

C2 Lite UT™ tanks are made using a unique 3 piece internal construction design that allows for consistent engineered dome profiles and integrally bonded connections that lead to longer tank life. Its heavy duty base is molded out of ABS for maximum strength and durability. And, the C2 Lite UT™ tank has a removable schedule 80 PVC bottom connection that can be “accessorized” for increased installation flexibility. C2-Lite UT™ tanks are built to the same stringent quality standards as GWS steel tanks.

C2-Lite UT™ tanks are easy to install, weather resistant and engineered to withstand even extreme environmental conditions. When it comes to performance and durability, the GWS C2-Lite UT™ design cannot be beat.

C2-Lite UT™ tanks are quality tested at several stages on the production line to insure the structural integrity of every tank. C2-Lite UT™ tanks represent the best value for the investment and are the best quality composite storage vessels available today.

SPECIFICATIONS C2-Lite UT™ Series Models

NPT/BSP		NPT/BSP		Nominal Volume		Shipping (box) Volume		Shipping (box) Weight		Dimensions							
Old Part Number	New Part Number	Old Part Number	New Part Number	liter	gal	m ³	ft ³	kg	lbs	A		B		C		D	
										cm	inches	cm	inches	cm	inches	cm	inches
C2UT115	CUB-115LV	C2UT115	CUN-115LV	115	30	0.20	7.00	7.40	16.3	112.78	44.40	4.50	1.80	41.80	16.60	23.90	8.10
C2UT150	CUB-150LV	C2UT150	CUN-150LV	150	40	0.25	8.80	10.00	22.1	140.46	55.30	4.50	1.80	41.80	16.60	23.90	8.10
C2UT300	CUB-300LV	C2UT300	CUN-300LV	300	80	0.52	18.30	25.80	56.9	167.64	66.00	5.70	2.30	54.20	21.50	30.20	10.70
C2UT450	CUB-450LV	C2UT450	CUN-450LV	450	120	0.74	26.00	38.20	84.2	186.44	73.40	5.70	2.30	61.40	24.30	34.00	12.30

Max. Working Pressure 6.9 bar / 100 psi
 Max. Working Temperature 49°C / 120°F

* Technical variance may occur

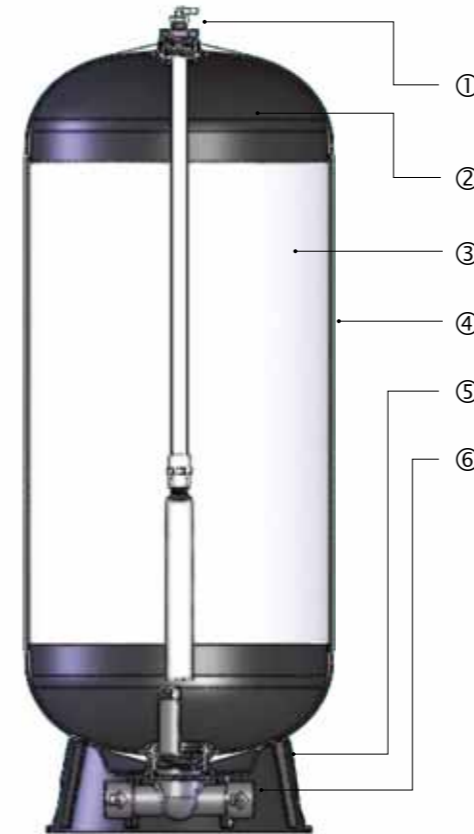

- ① Top port fitting: Glass filled stainless steel reinforced polypropylene insert molded into the top dome
- ② Top and bottom domes: Injection molded copolymer polypropylene
- ③ Shell: Extruded copolymer polypropylene
- ④ Outer shell: Fiberglass-wound, coated with epoxy resin
- ⑤ Base: Injection molded high-impact ABS
- ⑥ Water Connection: Removable PVC pipe

Accessories



AVC Kit



Air Injector (optional)

ISO:9001



ACS Approved



FlowThru™ SERIES



SPECIFICATIONS FlowThru™ Series Models

BSP		NPT		Nominal Volume		Shipping (box) Volume		Shipping (box) Weight		Dimensions			
Old Part Number	New Part Number	Old Part Number	New Part Number	liter	gal	m ³	ft ³	kg	lbs	A		B	
										cm	inches	cm	inches
Steel													
FTB80	GFU-80LV	FTN20	GFU-80LV	80	20	0.13	4.74	15.21	33.5	73.66	29.30	40.69	16.02
FTB170	GFU-170LV	FTN45	GFU-170LV	170	45	0.29	10.14	30.90	68.0	92.07	36.25	53.42	21.03
FTB325	GFU-325LV	FTN85	GFU-325LV	325	85	0.54	18.93	55.50	122.0	113.03	44.50	66.07	26.01
Composite													
FTCB60	CFB-60LV	FTCN15	CFN-15GV	60	15	0.13	4.44	8.60	19.0	64.00	25.60	42.16	16.60
FTCB80	CFB-80LV	FTCN20	CFN-20GV	80	20	0.16	5.53	10.90	24.0	86.51	34.06	42.16	16.60
FTCB150SQ	CFB-150LV	FTCN40SQ	CFN-40GV	150	40	0.32	11.45	15.90	35.0	77.44	30.49	61.72	24.30
FTCB200	CFB-200LV	FTCN50	CFN-50GV	200	50	0.34	11.95	20.20	44.5	109.98	43.30	54.61	21.50

* Technical variance may occur

System Connection: 1 1/4" BSP / NPT
 Max. Working Pressure 8.6 bar / 125 psi
 Max. Working Temperature 60°C / 140°F (steel) ; 49°C / 120°F (composite)
 Please refer to tank packaging for correct factory set pre-charge information.

FEATURES

- Patented Flow-Thru Technology for freshest water
- Available in Composite and Steel
- Patented CAD-2 diaphragm technology
- No stagnation
- Patented Watervane, total recirculation of the water
- Leak free air valve cap sealed with closed cell foam
- Comprehensive testing
- No maintenance

Global Water Solutions now guarantees the freshest water quality possible with the revolutionary Flow-Thru™ Series design, available in both composite and steel models. All Flow-Thru™ tanks feature GWS's exclusive patented Flow-Thru™ technology which assures that your system will provide the freshest water quality possible by simply eliminating stagnation!

The Flow-Thru™ connection diverts system water into, and more importantly out of the tank while the pump is running. This constant flushing action assures that the water in the tank remains as fresh as possible and eliminates the possibility of stagnant water during normal system operation.

Both our steel and composite Flow-Thru™ tanks incorporate our proven patented controlled action diaphragm (CAD-2). CAD-2's steel clench ring regulates movement and prevents the diaphragm from rubbing against the tank wall.

Flow-Thru™ is also the ideal solution for constant pressure water system installers seeking to store water without the risk of stagnation.

Flow-Thru™ tanks are quality tested at several stages on the production line to insure the structural integrity of every tank. Flow-Thru™ tanks represent the best value for the investment and are the best quality Flow-Thru™ vessels available today.

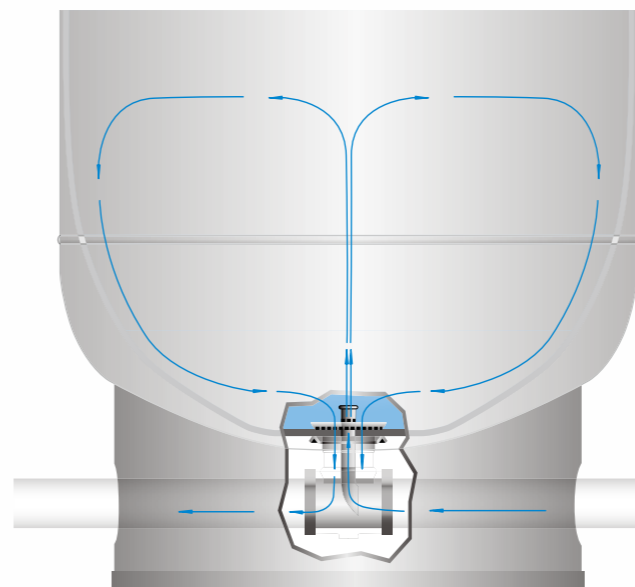

Flow-Thru™ technology assures total recirculation of the tank's water content.

Patented watervane flushes water through the tank eliminating the possibility of stagnant water.

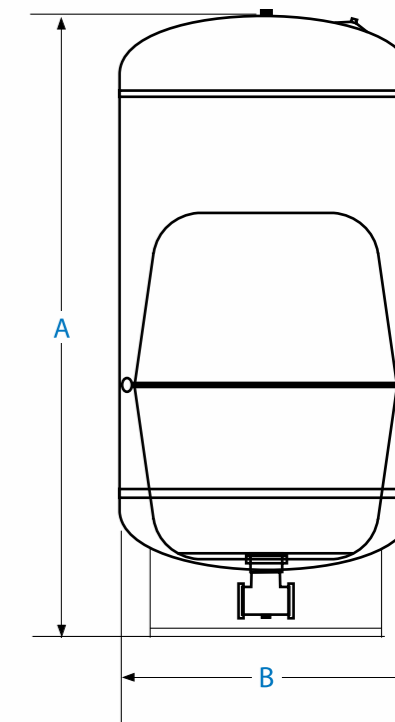

SuperFlow™ SERIES



FEATURES

- 8 to 10,000 liters for sizes not covered by PressureWave™ and Challenger™ Series
- 10, 16 and 25 bar pressure rating
- Almond RAL 1013
- Built-in pressure gauge (Models SF100-SF10,000)
- ISO : 9001, CE approved

The SuperFlow™ Series

Global Water Solutions' SuperFlow™ tanks are ideally suited for applications where high-pressure ratings are required. These applications include booster systems, heating expansion and hammer arresting in high-rise and multistory buildings such as hotels, hospitals or business centres.

SuperFlow™ tanks range from 8 to 10,000 litres and are available in 10, 16 and 25 bar pressure ratings which makes GWS one of the most comprehensive suppliers globally. The interchangeable membrane design of the tanks allows you to replace the membrane whenever required, and the built-in pressure gauge, starting at tanks of 100 litres size, makes the system-pressure control as easy as possible.

SuperFlow™ Series vessels are quality checked at several stages during the production and given regular maintenance, we recommend pre-charge check every 3 month, these vessels represent the best value for the investment and are designed to serve your needs for years to come.

SPECIFICATIONS SuperFlow™ Series Models

Model Numbers			Connection	Nominal Volume	Ship Weight			Dimensions	
Inline 10 bar	Inline 16 bar	Inline 25 bar			10 bar	16 bar	25 bar	A	B
N/A*	N/A*	SF1225	1"	12	N/A	N/A	9	22	38
N/A*	N/A*	SF1925	1"	19	N/A	N/A	11	28	43
N/A*	N/A*	SF3525	1"	35	N/A	N/A	22	38	47
Vertical 10 bar	Vertical 16 bar	Vertical 25 bar	inches	liters	kg	kg	kg	cm	cm
N/A*	N/A*	SF5025V	1"	50	N/A	N/A	30	38	75
N/A*	N/A*	SF6025V	1"	60	N/A	N/A	33	38	81
N/A*	SF8016V	SF8025V	1"	80	N/A	26	46	43	96
N/A*	SF10016V	SF10025V	1"	100	N/A	28	51	46	99
N/A*	SF15016V	SF15025V	1"	150	N/A	50	85	50	110
N/A**	SF20016V	SF20025V	1 1/4"	200	N/A	68	112	59	112
N/A**	SF30016V	SF30025V	1 1/4"	300	N/A	79	130	64	123
N/A**	SF50016V	SF50025V	1 1/4"	500	N/A	115	202	75	155
SF75010V	SF75016V	SF75025V	2"	750	110	220	328	75	195
SF85010V	SF85016V	SF85025V	2"	850	145	235	344	80	195
SF100010V	SF100016V	SF100025V	2"	1000	165	250	368	80	218
SF150010V	SF150016V	SF150025V	2"	1500	250	375	495	96	238
SF200010V	SF200016V	SF200025V	2"	2000	370	520	745	110	252
SF300010V	SF300016V	SF300025V	2 1/2"	3000	550	780	910	120	280
SF400010V	SF400016V	SF400025V	3"	4000	730	980	1290	145	310
SF500010V	SF500016V	SF500025V	3"	5000	840	1140	1472	145	372
SF1000010V	SF1000016V	SF1000025V	4"	10000	1920	2500	2980	160	575
Horizontal 10 bar	Horizontal 16 bar	Horizontal 25 bar	inches	liters	kg	kg	kg	cm	cm
N/A*	N/A*	SF2425H	1"	24	N/A	N/A	13.5	47	28
N/A*	N/A*	SF5025H	1"	50	N/A	N/A	30	62	38
N/A*	N/A*	SF6025H	1"	60	N/A	N/A	33	67	38
N/A*	SF8016H	SF8025H	1"	80	N/A	26	46	72	43
N/A*	SF10016H	SF10025H	1"	100	N/A	28	51	80	46

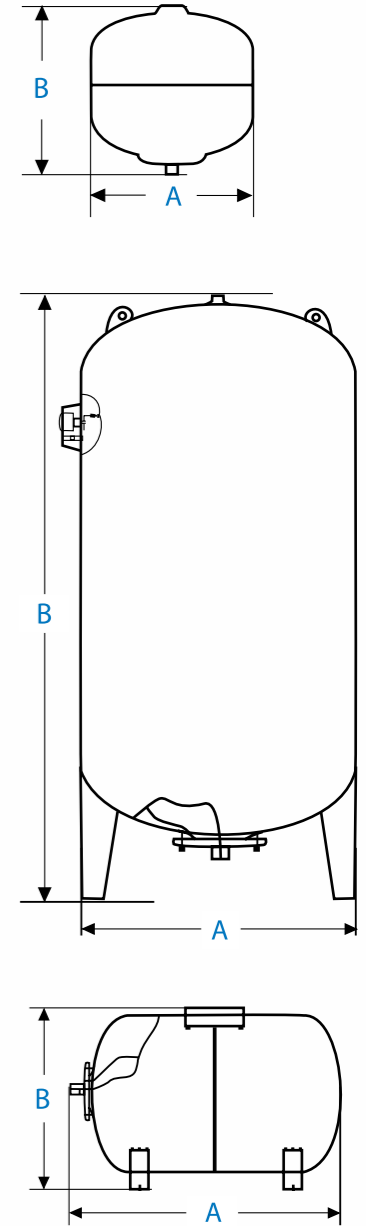

* Technical variance may occur

Interchangeable membranes

EPDM for SF12-SF2000, Butyl for SF3000 - SF10000, working temperature -5°C / 23°F to 90°C / 194°F
 Tank precharge: 4.0 bar / 58 psi

*Use PressureWave™, Max™ or UltraMax™ Series tanks ** Use Challenger™ Series tanks

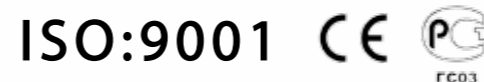

RoWave™ SERIES



FEATURES

- Patented stainless steel water connection
- High grade butyl diaphragm
- Virgin polypropylene liner
- Two part polyurethane, epoxy primed paint finish
- Leak free, o-ring sealed air valve cap
- NSF 58/61, CE/PED, ACS, WRAS, Evrazes approvals
- Comprehensive testing

If you are looking for the proven performance of a GWS tank RoWave™ tanks are the quality solution for your RO system.

The virgin polypropylene shell, high grade butyl rubber diaphragm, and patented stainless steel water connection combine to make a pristine non-corrosive water chamber. By only using the finest materials available we ensure that our tank will not taint your pure water.

Constructed of deep drawn steel domes, RoWave™ provides an unparalleled reliability in the RO industry. Its air chamber sealed with a brass air valve and o-ring sealed air cap will provide many years of leak free and service free life. Its two part polyurethane, epoxy primed paint finish will withstand the harshest indoor and outdoor climates throughout the world.

RoWave™ tanks are quality tested at several stages on the production line to insure the structural integrity of every tank.

SPECIFICATIONS

RoWave™ Series Models

Model #'s		Nominal Volume		Shipping (box) Volume		Shipping (box) Weight		Dimensions					
Old Part Number	New Part Number	liter	gal	m ³	ft ³	kg	lbs	A		B		C	
		cm	inches	cm	inches	cm	inches	cm	inches	cm	inches	cm	inches
Inline Models													
ROW4	RWN-4LX	4	1.1	0.07	0.265	1.60	3.53	24.50	9.65	16.20	6.38		
ROW8	RWN-8LX	8	2.1	0.16	0.55	2.24	4.94	29.70	11.69	20.20	7.95		
ROW12	RWN-12LX	12	3.2	0.20	0.72	2.93	6.46	34.90	13.74	23.00	9.06		
ROW18	RWN-18LX	18	4.8	0.29	1.03	3.60	7.94	35.10	13.82	27.90	10.98		
ROW21	RWN-21LX	21	5.5	0.37	1.3	4.43	9.77	39.00	15.35	29.00	11.42		
Vertical Models													
ROW35	RWN-35LV	35	9.2	0.55	1.93	7.11	15.67	47.80	18.82	31.80	12.52	4.50	1.77
ROW60V	RWB-60LV	60	15.9	0.93	3.3	10.83	23.88	57.50	22.64	38.90	15.31	10.00	3.94
ROW80V	RWB-80LV	80	21.1	1.27	4.5	14.52	32.01	77.10	30.35	38.90	15.31	10.00	3.94
ROW100V	RWB-100LV	100	26.4	1.61	5.7	19.06	42.02	80.40	31.65	43.00	16.93	12.90	5.08
Plasteel™													
TP12P	RPN-12LX	12	3.2	0.23	0.8	3.59	7.91	38.20	15.04	24.10	9.49		
TP16P	RPN-16LX	16	4.2	0.28	0.98	3.71	8.18	39.00	15.35	25.10	9.88		
TP18P	RPN-18LX	18	4.8	0.37	1.3	4.20	9.26	40.00	15.75	27.50	10.83		

Maximum Working Pressure 7 bar / 100 psi; Tank pre-charge: 0.5 bar / 7 psi
 Models RWN-4LX - RWN-35LV 1/4" NPT connection with plastic ball valve
 Models RWB-60LV - RWB-100LV 1" BSP elbow connection with 1" NPT plastic extension
 Maximum Working Temperature: 50°C / 122°F



- ① Patented stainless steel water connection
- ② High grade butyl diaphragm
- ③ Two-part polyurethane/epoxy primed paint finish
- ④ Virgin polypropylene liner
- ⑤ Leak-free o-ring sealed air valve cap

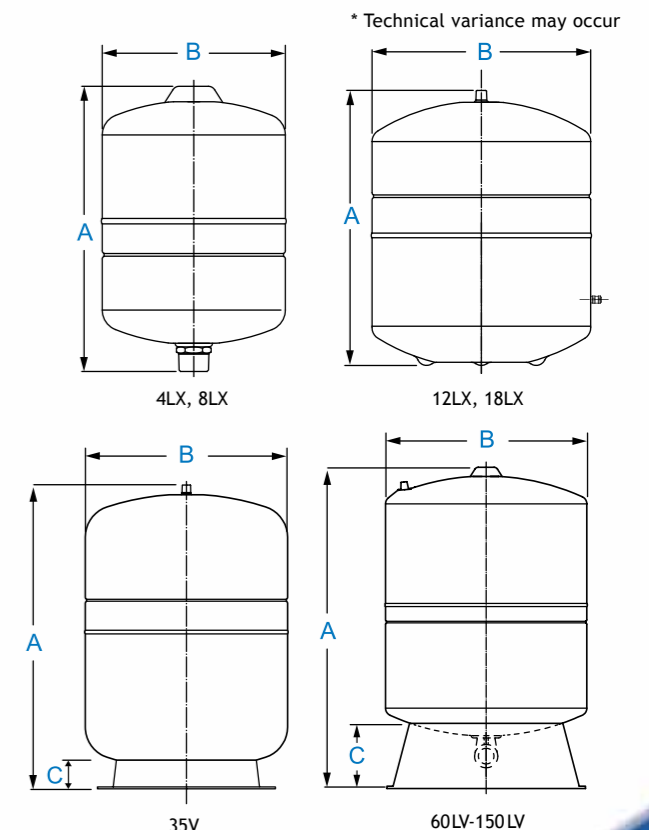

ThermoWave™ SERIES



FEATURES

- High grade butyl diaphragm
- Virgin polypropylene liner
- Two part polyurethane, epoxy primed paint finish
- Patented stainless steel water connection
- Leak free, o-ring sealed air valve cap
- Comprehensive testing
- Maintenance free

ThermoWave™ expansion tanks are specially designed for use in potable water heating applications.

Many homes and buildings have potable water heating systems to provide hot water for washing, cooking, showering, etc. As the water is heated it also expands. This expansion leads to increased system pressure and can cause serious damage. In most systems a relief valve is installed to vent the expanded water volume and prevent the system from exceeding maximum operating pressure. Unfortunately this creates wasted energy as hot water is vented and additional water must be filled and heated again. In order to safely accommodate the natural expansion of water without venting from a relief valve, a ThermoWave™ expansion tank is used. ThermoWave™ expansion tanks conserve water and energy while safely maintaining system operating pressures. They do so by temporarily absorbing the expanded water volume instead of allowing it to be vented out of a relief valve. And because ThermoWave™ expansion tanks use water chambers constructed from high grade Chlorobutyl diaphragms and virgin polypropylene liners they ensure your potable water remains clean and safe.

ThermoWave™ expansion tanks are quality tested at several stages on the production line to ensure the structural integrity of every tank.

ThermoWave™ expansion tanks represent the best value for the investment and are the best quality expansion tanks available today.

SPECIFICATIONS

ThermoWave™ Series Models

Model #'s		Nominal Volume		Shipping (box) Volume		Shipping (box) Weight		Dimensions					
Old Part Number	New Part Number	liter	gal	m ³	ft ³	kg	lbs	A		B		C	
								cm	inches	cm	inches	cm	inches
Inline Models													
TW2	TWB-2LX	2	0.5	0.055 (12 pcs/box)	1.94 (12 pcs/box)	13.38 (12 pcs/box)	29.5 (12 pcs/box)	20.6	8.1	12.6	5.0		
TW4	TWB-4LX	4	1.1	0.0075	0.26	1.60	3.53	25.80	10.16	16.20	6.40		
TW8	TWB-8LX	8	2.1	0.014	0.49	2.20	4.85	31.00	12.20	20.20	7.95		
TW12	TWB-12LX	12	3.2	0.023	0.81	2.90	6.39	36.20	14.25	23.00	9.06		
TW18	TWB-18LX	18	4.8	0.029	1.02	3.84	8.47	36.40	14.33	27.90	11.20		
TW24	TWB-24LX	24	6	0.042	1.48	4.90	10.80	44.40	17.48	29.00	11.42		
TW35	TWB-35LX	35	9.2	0.058	2.05	6.70	14.77	47.80	18.90	31.80	12.52		
Horizontal Models													
TW20H	TWB-20LH	20	5.3	0.042	1.48	5.20	11.46	44.70	17.60	27.90	10.98	14.70	5.79
TW24H	TWB-24LH	24	6	0.047	1.66	5.90	13.01	44.70	17.60	30.60	12.05	16.10	6.40
TW35H	TWB-35LH	35	9.2	0.058	2.05	6.90	15.21	48.10	18.90	33.80	13.31	17.90	7.05
TW60H	TWB-60LH	60	14	0.08	2.83	11.50	25.35	53.00	20.87	40.90	16.10	21.50	8.46
Vertical Models w/ base													
TW60V	TWB-60LV	60	14	0.08	2.83	10.80	23.81	62.00	24.41	38.90	15.31	12.70	5.00

* Technical variance may occur

System Connection: 3/4" BSP
 Maximum Working Pressure: 10 bar / 150 psi
 Factory pre-charge: 1.9 bar / 28 psi
 Maximum Working Temperature: 90°C / 194°F

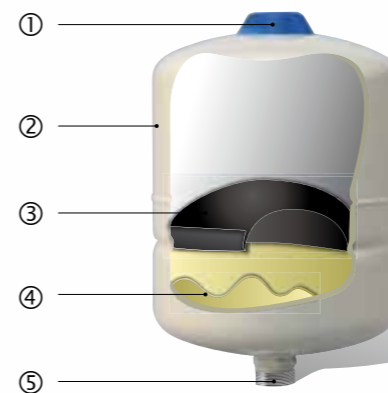

- ① Leak-free O-ring sealed air valve cap
- ② Two-part polyurethane epoxy primed paint finish
- ③ High grade butyl diaphragm
- ④ Polypropylene Liner
- ⑤ Patented stainless steel water connection

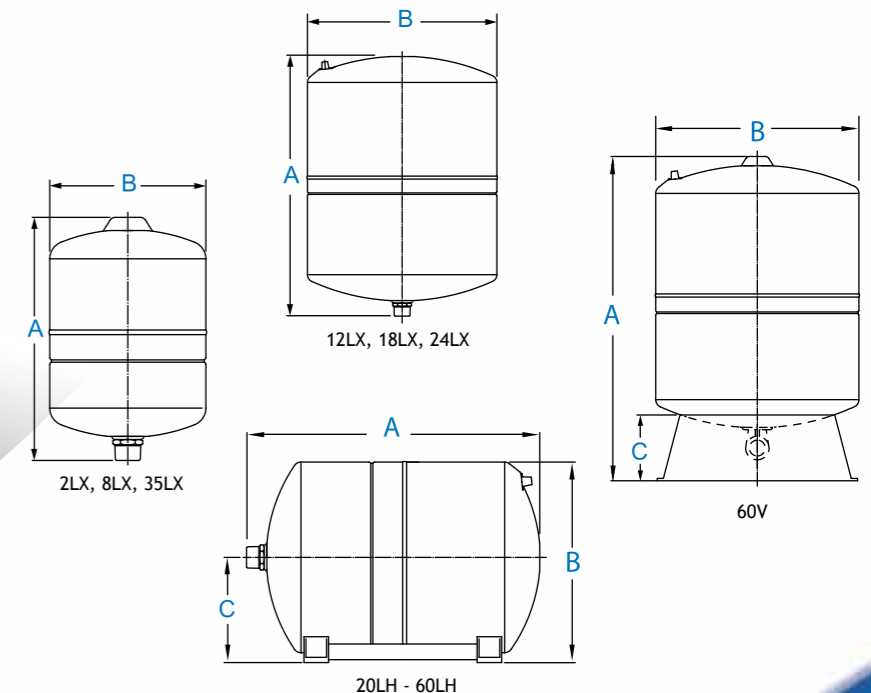

ISO:9001



ACS Approved



HeatWave™ SERIES



FEATURES

- High grade butyl diaphragm
- Two part polyurethane, epoxy primed paint finish
- Leak free, o-ring sealed air valve cap
- Comprehensive testing
- ISO:9001, GOST, CE/PED approved

HeatWave™ tanks are the quality solution for hydronic expansion. HeatWave™ tanks are built to the same stringent standards as the PressureWave™ and Challenger™ tanks.

With an incorporated hex nut system connection, HeatWave™ tanks are easy to install. Its air chamber sealed with a brass air valve and o-ring sealed air cap will provide many years of leak free and service free life. Its two part polyurethane, epoxy primed paint finish will withstand the harshest indoor and outdoor climates throughout the world. HeatWave™ tanks are quality tested at several stages on the production line to insure the structural integrity of every tank.

The HeatWave™ expansion tank is designed to be either supported by the system piping, the wall mounting bracket (inline models) or freestanding (vertical models w/ base).

The expansion tank, pipes and your connections if installed incorrectly could leak water. Install the expansion tank in a location where any water leak will not cause damage. The manufacturer is not responsible for any water damage in connection with this expansion tank.

SPECIFICATIONS HeatWave™ Series Models

Model #'s		Nominal Volume		Shipping (box) Volume		Shipping (box) Weight		Dimensions					
Old Part Number	New Part Number	liter	gal	m ³	ft ³	kg	lbs	A		B		C	
				cm	inches	cm	inches	cm	inches	cm	inches	cm	inches
Inline Models													
HW2	HWB-2LX	2	0.5	0.055	1.94	12.83	28.29	20.90	8.23	12.60	4.96		
HW8	HWB-8LX	8	2.1	0.016	0.57	2.20	4.85	31.30	12.32	20.20	7.95		
HW12	HWB-12LX	12	3.2	0.023	0.81	2.90	6.39	36.70	14.45	23.00	9.06		
HW18	HWB-18LX	18	4.8	0.029	1.02	3.80	8.38	36.70	14.45	27.90	11.20		
HW24	HWB-24LX	24	6	0.042	1.48	4.90	10.80	44.70	17.60	29.00	11.42		
HW35	HWB-35LX	35	9.2	0.058	2.05	6.70	14.77	48.10	18.94	31.80	12.50		
Vertical Models w/ base													
HW60V	HWB-60LV	60	14	0.102	3.60	10.80	23.81	57.60	22.68	38.90	15.31	16.00	6.30
HW80V	HWB-80LV	80	20	0.134	4.73	15.30	33.73	77.10	30.35	38.90	15.31	16.00	6.30
HW100V	HWB-100LV	100	26.4	0.168	5.93	18.20	40.12	80.40	31.65	43.00	16.90	12.90	5.08
HW150V	HWB-150LV	150	40	0.21	7.41	26.78	59.04	107.40	42.28	43.00	16.90	12.90	5.08

Factory pre-charge: HWB-2LX-HWB-24LX 0.7 bar / 10 psi - HWB-35LX 1 bar / 15 psi - HWB60LV-HWB-150LV 1.5 bar / 22 psi
 Maximum Working Temperature: 99°C / 210°F
 Maximum working pressure 10 bar / 150 psi
 System Connection: Steel 3/4" BSP - Steel 1" BSP

* Technical variance may occur

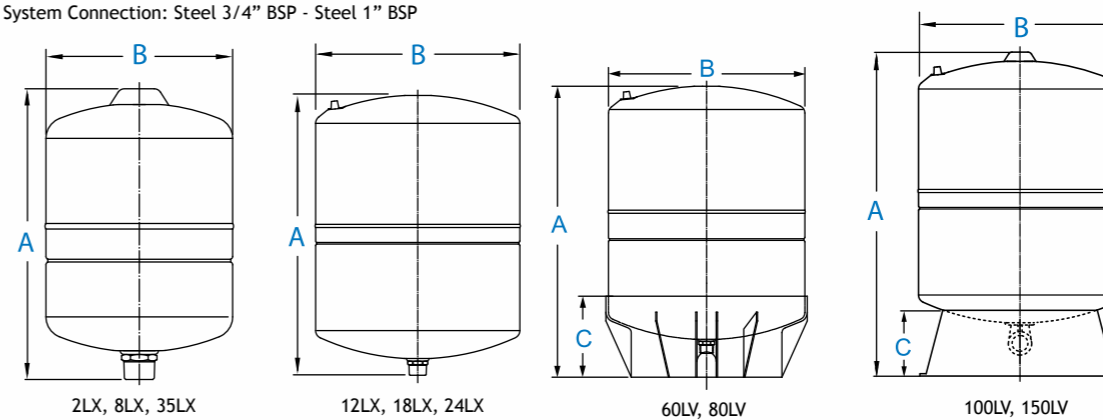

Wall mounting bracket kits	
BR200	HWB-8LX
BR280	HWB-18LX
BR290	HWB-24LX
BR320	HWB-35LX
BR390	HWB-60LV HWB-80LV



SolarWave™ SERIES



FEATURES

- High temperature butyl diaphragm
- High expansion volume factor
- Patented stainless steel connection
- Two part polyurethane, epoxy primed paint finish
- Leak free o-ring sealed air valve cap
- Comprehensive testing
- No maintenance

If you are looking for the proven performance of a GWS tank, SolarWave™ expansion tanks are the quality solution for your solar system. SolarWave™ expansion tanks are designed to control the expansion and contraction of solar thermal transfer fluids in solar heating systems. The SolarWave™ Series is intended for use on the solar liquid loop of indirect thermal transfer systems.

SolarWave™ tanks are built to the same stringent standards as PressureWave™ and Challenger™ tanks. They meet the demands of solar collector systems for both thermal expansion and contraction in order to maintain safe and efficient operating pressures within the solar liquid system.

A properly sized SolarWave™ tank will eliminate the need for recharging the system after periods of no use or in cases of extreme temperature buildup. It will eliminate relief valve release of system liquid and maintain minimum operating pressures throughout the system.

SolarWave™ Series expansion tanks have a large acceptance volume making them ideal for expansion and contraction control of solar collector systems which operate under a wide range of pressure and temperature.

SolarWave™ tanks are quality tested at several stages on the production line to insure the structural integrity of every tank. SolarWave™ tanks represent the best value for the investment and are the best quality solar expansion vessels available today.

SPECIFICATIONS SolarWave™ Series Models

Model #s		Nominal Volume		Shipping (box) Volume		Shipping (box) Weight		Dimensions					
Old Part Number	New Part Number	liter	gal	m ³	ft ³	kg	lbs	A		B		C	
		cm	inches	cm	inches	cm	inches	cm	inches	cm	inches	cm	inches
Inline Models													
SW2	SWB-2LX	2	0.53	0.055	1.94	13.38	29.5	20.90	8.23	12.60	4.96		
SW8	SWB-8LX	8	2.1	0.016	0.57	2.20	4.85	31.30	12.32	20.20	7.95		
SW12	SWB-12LX	12	3.2	0.023	0.81	2.90	6.39	36.40	14.33	23.00	9.06		
SW18	SWB-18LX	18	4.8	0.029	1.02	3.80	8.38	36.70	14.45	27.90	10.98		
SW24	SWB-24LX	24	6	0.042	1.48	4.90	10.80	44.70	17.60	29.00	11.42		
SW35	SWB-35LX	35	9.2	0.058	2.05	6.70	14.77	48.10	18.94	31.80	12.50		
Vertical Models w/ base													
SW60V	SWB-60LV	60	14	0.102	3.60	10.80	23.81	57.60	22.68	38.90	15.31	16.00	6.30
SW80V	SWB-80LV	80	20	0.134	4.73	15.30	33.73	77.10	30.35	38.90	15.31	16.00	6.30
SW100V	SWB-100LV	100	26.4	0.168	5.93	18.20	40.12	80.40	31.65	43.00	16.90	12.90	5.08
SW150V	SWB-150LV	150	40	0.21	7.41	26.78	59.04	107.40	42.28	43.00	16.90	12.90	5.08

* Technical variance may occur

Maximum system temperature: 130°C / 266°F

Maximum working pressure: 10 bar / 150 psi

System connection: SWB-8LX - SWB-80LV stainless steel 3/4" BSP inline ; SWB-100LV - SWB-150LV stainless steel 1" BSP elbow

Factory pre-charge: 1.9 bar / 28 psi

Above 150 liter use Challenger™ Series tanks

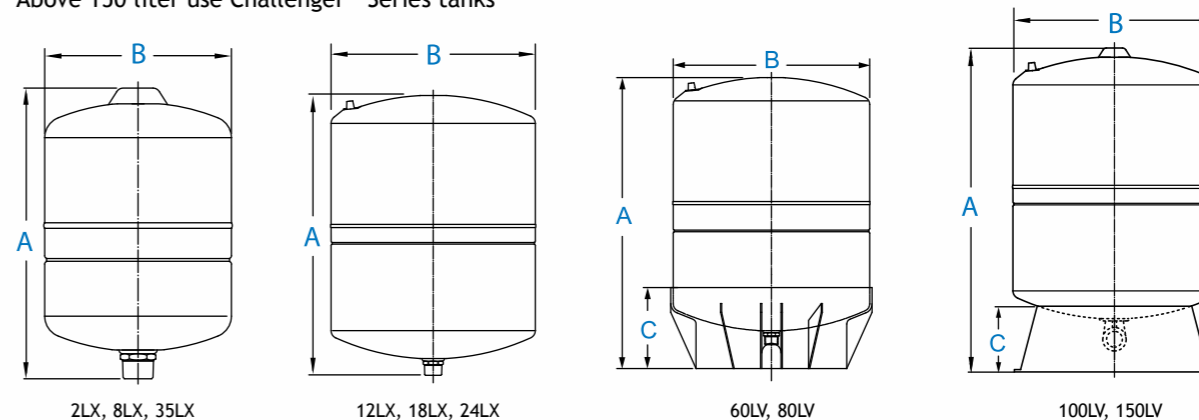

If the temperature of the solar system has the potential to rise above the evaporation point of the solar liquid a condenser chamber or coil is required between the solar collector and SolarWave™ Series expansion tank in order to control the maximum fluid temperature at the SolarWave™ tank.



SpringTech™ SERIES



Vortech™



FEATURES

- Flexibility in picking sizes and components
- Vortech™ bottom distribution system for a cleaner and more efficient system with less backwash
- Additional Mid-Vortech™ option as a mid plate distributor eliminates the need of a second media tank
- No leakage (special injection process and mechanical welding of the glass-filled threaded inlet to the dome eliminate leaking)
- Unique 3-piece-design allows access to inside of tank during construction
- Superior impact resistance, consistent and strong quality
- Superior elasticity of co-polymer polypropylene used allows for controlled “breathing” without stressing the material
- CE, NSF, ACS, approved
- Comprehensive testing

Global Water Solutions now introduces the SpringTech™ series, a series of exclusive quality composite vessels for water treatment systems featuring the revolutionary Vortech™ technology which ensures purest water quality. The patented Vortech™ is the world’s newest, innovative and most efficient bottom distribution system. Cleaning is greatly improved, freeboard is reduced, and it works with all softening and filtrating medias. The SpringTech™ series with the unique Vortech™ technology provides a cleaner and more efficient system. Advanced computerized manufacturing processes and finest materials used make the SpringTech™ series composite vessels for water treatment systems stronger and superior to the competitor’s vessels.

VORTECH™ -The Revolutionary New Distribution Technology

FEATURES & BENEFITS

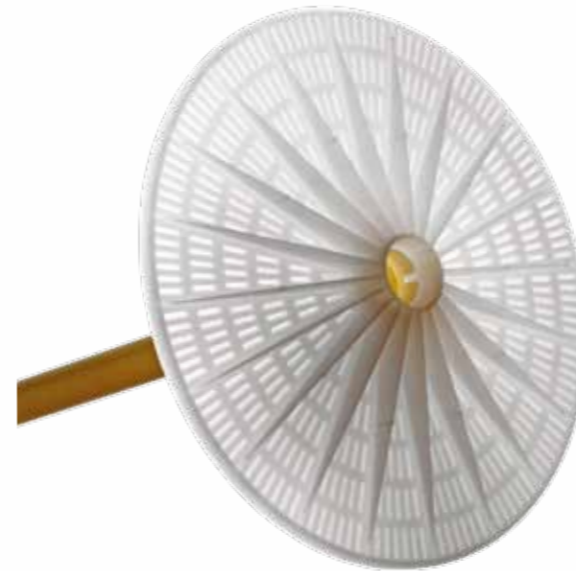

- Up to 30% less backwash flow rate is required, conserving water for the consumer
- High flow design maximizes today’s high efficiency valve technology
- Permanent attachment of dip tube to distributor, so when servicing a valve, distributor stays in place, no more re-bedding
- Elimination of gravel, saves net costs and unit weight for shipping
- Improved system pressure drop characteristics
- Self-cleaning nozzle design eliminates potential clogging and build-up
- Increase in softening capacity, due to improved flow through media
- No channeling of media, providing a cleaner more efficient system
- Environmentally friendly, reduction in required backwash times due to improved bed lift and mixing at lower flow rates
- Most efficient softening regeneration, reducing salt consumption

Third Party Validation*

	Capacity Test @ 4.5 lbs of salt**	Gallons to drain**	Pressures / Δ p	Backwash time***	Pressure drop***
Cone & gravel	3472 grains	53.7	13.4 gpm @ 15psig Δ p	14 minutes	25 psi
Vortech™	4186 grains	31	@15psig Δ p, Flow rate 17.8 gpm	8 minutes	10 psi
Improvement	Increase of 21%	Decrease of 42%	Increase of 33% in flow rate	Saving up to 150 gal water/ cycle	Decrease of 60%

*Detailed test results available upon request **ST1040 ***ST1665

Backwash Comparison (Vortech™ vs. Cone)

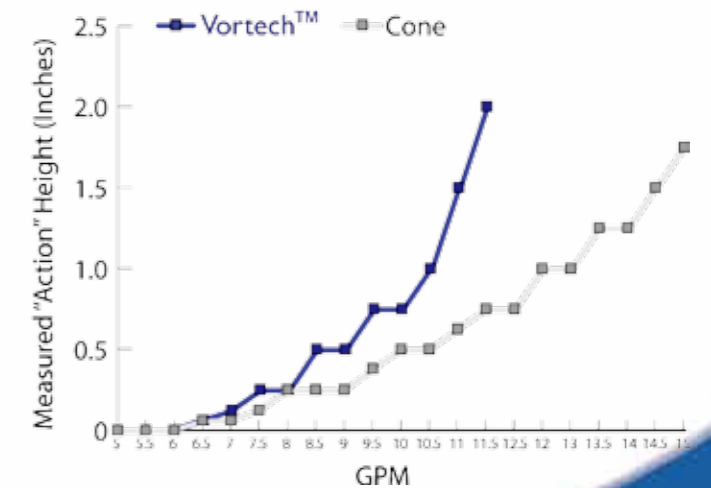
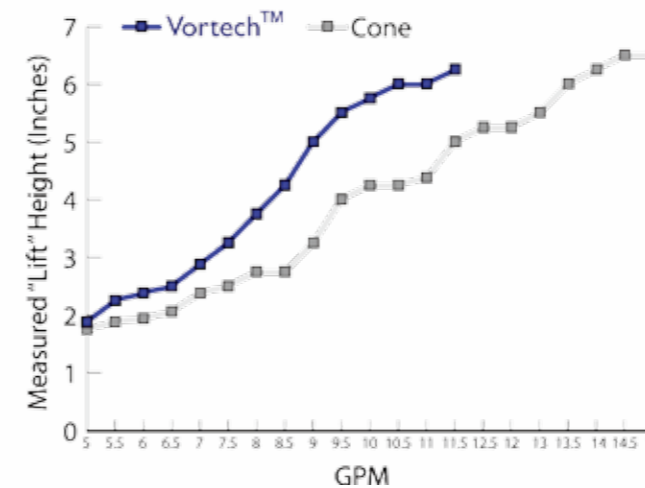

Carbon 13" Diameter, Temperature 42°F, Quantity of Media 2.5 ft³, Weight of Underbedding - Cone 45 lbs

SPECIFICATIONS SpringTech™ Series Models

Model #'s	Weight per Tank		Pieces per Box	Shipping Volume per Box		Shipping Weight per Box		Dimensions				
	Old Part Number	kgs		lbs	m ³	ft ³	kgs	lbs	A		B	
								cm	inches	cm	inches	
ST724		2.7	6	24	1.26	44.67	97.1	214			61	24
ST735		3.2	7	24	1.17	41.47	108	238	17.8	7	88.9	35
ST744		3.6	8	24	1.26	44.67	118.8	262			111.8	44
ST818		1.8	4	28	1.17	41.47	82.6	182			45.7	18
ST824		2.2	4.8	32	1.17	41.47	100.7	222			61	24
ST830		2.4	5.3	18	1.26	44.67	74.6	165			76.2	30
ST835		2.7	6	18	1.17	41.47	80.7	178	20.3	8	88.9	35
ST840		3.1	6.8	18	1.26	44.67	86.9	192			101.6	40
ST844		3.3	7.3	18	1.26	44.67	90.9	201			111.8	44
ST918		2.4	5.2	28	1.17	41.47	97.8	216			45.7	18
ST935		4.2	9.3	18	1.17	41.47	107.7	237			88.9	35
ST940		5.4	12	14	1.26	44.67	108	238	22.9	9	101.6	40
ST942		5.4	12	16	1.48	52.14	118.8	262			106.7	42
ST948		6.4	14	16	1.48	52.14	133.4	294			121.9	48
ST1018**		4.3	9.5	48	1.73	61.05	238.6	526			45.7	18
ST1022**		4.5	10	32	1.17	41.47	176.9	390			55.9	22
ST1024**		5	11	32	1.48	52.14	191.4	422			61	24
ST1030**		5.7	12.5	12	1.17	41.47	99.8	220			76.2	30
ST1035**		6.4	14	12	1.17	41.47	108	238			88.9	35
ST1040**		6.8	15	12	1.26	44.67	113.4	250	25.4	10	101.6	40
ST1044**		7.1	15.8	12	1.26	44.67	117.5	259			111.8	44
ST1047**		7.4	16.3	14	1.48	52.14	134.9	298			119.4	47
ST1054**		7.9	17.5	16	1.73	61.05	158.8	350			137.2	54
ST1060**		8.5	18.8	1	0.12	4.41	40.3	89			152.4	60
ST1065**		9.1	20	1	0.13	4.76	40.8	90			165.1	65
ST1229		5.4	12	9	1.17	41.47	80.7	178			73.7	29
ST1236		6.1	13.5	9	1.26	44.67	86.9	192			91.4	36
ST1242		6.8	15	9	1.26	44.67	93	205	30.5	12	106.7	42
ST1244		7.1	15.8	9	1.26	44.67	96	212			111.8	44
ST1248		7.6	16.8	9	1.48	52.14	100.1	221			121.9	48
ST1252		8.6	19	9	1.73	61.05	109.3	241			132.1	52
ST1330**		7.3	16	12	1.17	41.47	118.8	262			76.2	30
ST1335**		7.7	17	12	1.17	41.47	124.3	274			88.9	35
ST1348**		8.6	19	9	1.48	52.14	109.3	241	33	13	121.9	48
ST1354**		9.5	21	9	1.73	61.05	117.5	259			137.2	54
ST1360**		10.4	23	1	0.2	7.02	42.2	93			152.4	60
ST1365**		11.3	25	1	0.21	7.48	43.1	95			165.1	65
ST1430*		7.7	17	10	1.17	41.47	108.9	240			76.2	30
ST1454*		13.2	29	8	1.73	61.05	137	302	35.6	14	137.2	54
ST1465*		15.9	35	1	0.25	8.71	47.6	105			165.1	65
ST1472*		17.7	39	1	0.25	8.71	49.4	109			182.9	72
ST1623*		8.2	18	1	0.12	4.18	39.9	88			58.4	23
ST1636*		12.7	28	1	0.18	6.35	44.5	98	40.6	16	91.4	36
ST1653*		18.6	41	1	0.26	9.19	50.3	111			134.6	53
ST1665*		22.7	50	1	0.35	12.36	54.4	120			165.1	65

Maximum operating pressure: 10 bar / 150 psi
 Top Opening Connection: 2.5" NPSM
 *Also available in 4" UN connection
 **Mid-Vortech™ mid plate distributor available for 10" and 13" diameter vessels
 All tanks come with Vortech™ bottom distributor plate

Maximum operating temperature: 50°C / 122°F
 Dome hole option available for 10", 12" and 13" diameter vessels

* Technical variance may occur

VESSEL MATERIAL SPECIFICATIONS

Co-Polymer Polypropylene Inner Shell Material

Superior elasticity allows for controlled "breathing" without stressing the material

Superior impact resistance and superior performance in hot and cold environments

Extruded side wall produces consistent wall thickness over the entire length of the part eliminating potential thin spots or stress points

Vortech™ bottom distribution system for a cleaner and more efficient system

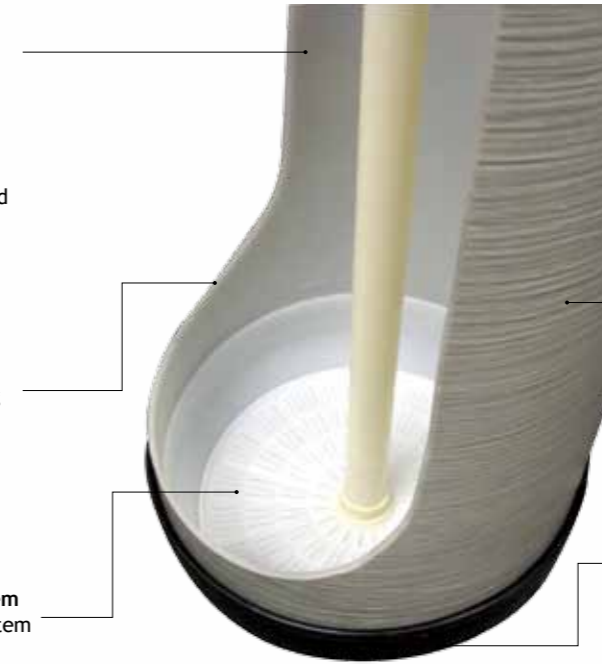

High temperature/high pressure injection molding allows the glass-filled threaded inlet to be mechanically welded to the dome eliminating potential leak paths

Premium Fiberglass/Epoxy Winding (computer controlled)

Epoxy laminate is oven cured for superior environmental performance

Injection Molded Base

Injection molded from impact/temperature resistant polypropylene

ADDITIONAL FEATURES AVAILABLE UPON REQUEST

Mid-Vortech™ Option available for 10" and 13" Vessels



Exclusive internal mid plate distributor Mid-Vortech™ eliminates the need for a second media tank and valve by creating physical separation of medias within a single tank.

Reduces plumbing and packaging requirements and saves water, salt and the environment!

DI Exchange Vessels and Accessories



DI Exchange Heads



Extended Bases



PumpWave™ SERIES



FEATURES

- Starting pressure adjustable from 1 to 2.5 bar
- LED Indicators: Power On, Pump On/Pump Off, Dry Run Control, Reset
- Relay for direct command of motor up to 1.5 kW 220 V AC 50/60 Hz

The PumpWave™ Series is an electronic autoclave pump control, which eliminates frequent small drawoff pump starts due to leaks and low flow pumping applications. PumpWave™ combines an internal water reservoir with an electronic control that allows for complete automatic management of most electric pumps. The process is simple. PumpWave™ draws water from the internal water reservoir until the adjustable START pressure is reached, then PumpWave™ switches the electronic pump on and allows it to run until there is no longer any flow within the system. PumpWave™ assures a constant flow and provides guaranteed protection against pump dry run. PumpWave™ simplifies pump installation as it doubles as a sturdy pump stand suitable for most electric pumps, saving space and assembly time.

PumpWave™ threads directly onto the 1" water connection of any GWS horizontal tank for full pump control with the right pressure tank.

Model	Weight (kg)	Max. Pressure (bar)	Connection	Dimensions	
				Height	Width
PUW Electronic	2.0	10	1" GAS	22 cm	15 cm

The PumpWave™ can also be purchased together with the PressureWave Series Horizontal tanks.

- PumpWave™ electronic is suitable for single-phase motors up to 1.5 kW
- Factory START pressure at 1.8 bar
- PumpWave™ must be installed with an electric pump with a minimum operating pressure of at least 1 bar above the programmed START pressure
- Maximum Capacity: 100 L/min

Accessories



3 Way Connector
A3WYC-BSP
 3 Way Brass Connector 1" MFF BSP
A3WYC-NPT
 3 Way Brass Connector 1" MFF NPT



5 Way Connector
A5WYC-BSP
 5 Way Brass Connector 1" MFF BSP
 1/4" MF
A5WYC-NPT
 5 Way Brass Connector 1" MFF NPT
 1/4" MF



Smart Pressure Valve
ASP1
 Smart Pressure Valve with check valve 1" NPT
ASP2
 Smart Pressure Valve without check valve 1" NPT



Pressure Switches
APSW2F
 Pressure Switch with 1/4" Female Connection 1.4-2.8 bar (20/40 psi)
APSW3F
 Pressure Switch with 1/4" Female Connection 2.1-3.4 bar (30/50 psi)



Pressure Gauges
A2PG
 2" Pressure Gauge 0-7 bar (100 psi) 1/4" male
A25PG
 2.5" Pressure Gauge 0-10 bar (145 psi) 1/4" male



Stainless Steel Flex Connector
A70MFC-BSP
 700mm M/F SS Flex Connector 1" BSP
A70MFC-NPT
 700mm M/F SS Flex Connector 1" NPT
A80MFC-BSP
 800mm M/F SS Flex Connector 1" BSP
A80MFC-NPT
 800mm M/F SS Flex Connector 1" NPT
A100MFC-BSP
 1000mm M/F SS Flex Connector 1" BSP
A100MFC-NPT
 1000mm M/F SS Flex Connector 1" NPT



Stainless Steel Flex Connector w/ Elbow
A70MFEC-BSP
 700mm M/F SS Flex Elbow Connector 1" BSP
A70MFEC-NPT
 700mm M/F SS Flex Elbow Connector 1" NPT
A80MFEC-BSP
 800mm M/F SS Flex Elbow Connector 1" BSP
A80MFEC-NPT
 800mm M/F SS Flex Elbow Connector 1" NPT
A100MFEC-BSP
 1000mm M/F SS Flex Elbow Connector 1" BSP
A100MFEC-NPT
 1000mm M/F SS Flex Elbow Connector 1" NPT



GWS also offers a wide range of filters and filter housings. Please contact us for details.

