

CAST IRON GATE VALVE

Ref. 150

Ref. : DS 150

Rev. : 6

Date : 10/09

Page 1/1



ASG Szerelvény Kft.
2800 Tatabánya, Vértanúk tere 20.
Tel./fax: +36-34/364-936
Mobil: +36-30/441-1532
Http://www.asgszerelveny.hu
E-mail: asg@asgszerelveny.hu



SPECIFICATIONS :

- . Single wedge disc
- . Inside screw stem
- . Flanges GN 10
- . Cast Iron

USE :

- . Water distribution and heating
- . Min and Max Temperature Ts : -10°C to + 90°C
- . Max Pressure Ps : 10 bars at 20°C to DN150
- . Max Pressure Ps : 6 bars from DN200 to DN300

RANGE :

- . Flanges GN 10 **Ref.150** DN40 to DN300



MATERIALS :

Item	DESIGNATION	MATERIALS
1	Body	Cast Iron EN GJL-250
2	Seat	Brass
3	Wedge	Cast Iron EN GJL-250
4	Wedge Trim	Brass
6	Stem	SS 420
7	Gasket	Graphite
8,9,13,16,17	Nut and washer	Carbon steel
10	Bonnet	Cast Iron EN GJL-250
11	Gasket	Graphite
12	Stem Gasket	O-ring EPDM
15	Handwheel	Cast Iron EN GJL-250

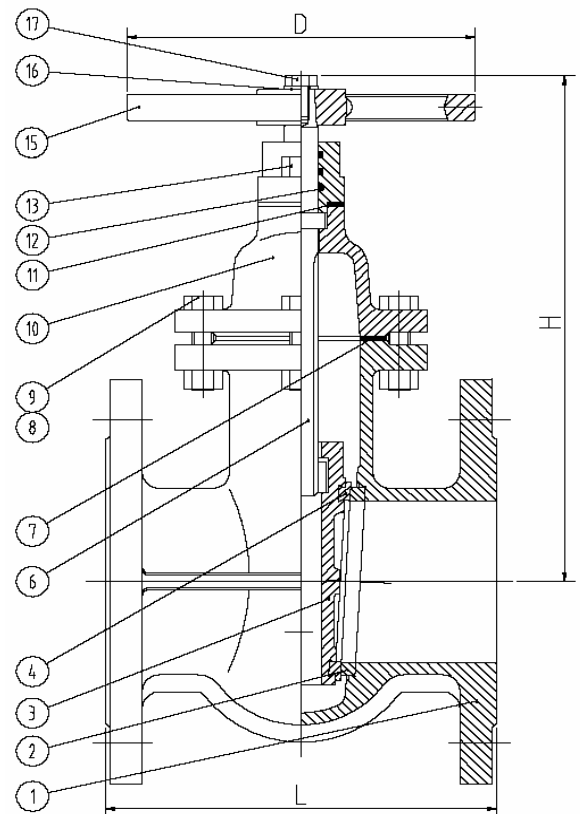

SIZE :

	DN	40	50	65	80	100	125	150	200	250	300
Ref. 150	L	140	150	170	180	190	200	210	230	250	270
	H	200	202	222	250	303	351	411	498	579	679
	D	130	140	160	160	185	200	240	240	360	360
	Weig.	8,7	10,8	12,8	16,6	22,75	32,1	42,9	71,3	98	145,2

STANDARDS :

- . Length according to DIN 3352
- . DIRECTIVE 97/23/CE : Products excluded from directive (Article 1, § 3.2)

ADVICE : Our opinion and our advice are not guaranteed and SFERACO shall not be liable for the consequences of damages. The customer must check the right choice of the products with the real service conditions.