

PURE WATER SYSTEMS

Crystal 7 RO and Pure series

The Crystal 7 Pure system (P/N C7-1001) is an entry level water purification system with very low system running costs. It is wall-mounted and does not require any space on a laboratory bench. The Crystal 7 Pure system produces purified water for general laboratory applications and analytical methods. Crystal 7 system water is used for many applications, including:

- Many inorganic methods of analysis (e. g. flame spectrophotometry)
- Wet chemistry methods
- Electrochemistry
- Labware washing, etc.

The Crystal 7 Pure system is a reliable source of purified lab water with conductivity < 0.1 $\mu\text{S}/\text{cm}$ (resistivity > 10 MegaOhm*cm). This exceeds requirements for Grade 2 water according to ISO 3696. The operating costs of a Crystal 7 Pure system are extremely low.

The Crystal 7 RO system (P/N C7-1241) produces water that complies with ISO 3696 Grade 3 requirements.

Specifications

Purified water specifications	Crystal 7 RO	Crystal 7 Pure
Purified water resistivity		>10 M Ω x cm
Purified water conductivity	<5 $\mu\text{S}/\text{cm}$	<0.1 $\mu\text{S}/\text{cm}$
Particles > 0.22 μm	<1 per mL	<1 per mL
Nominal flow, pure water (to storage tank)	7 L/h	7 L/h
Dispense flow, pure water	4 L/min	4 L/min
Deionization module life	N/A	1 m ³
Recovery	>30 %	>30 %
Dimensions (WxDxH), cm	50x20x52	50x20x52
Storage tank (option)	10 L – 60 L	10 L – 60 L
Feed water pressure	0.5 – 5 bar	0.5 – 5 bar
Feed water conductivity	< 900 $\mu\text{S}/\text{cm}$	< 900 $\mu\text{S}/\text{cm}$

The Crystal 7 Pure and RO systems are equipped with a graphic LCD display providing system status info and water quality monitoring readouts. The remaining pre-filter life and deionization (DI) module performance are shown on the LCD display. The smart DI module monitoring system provides a reduction in system operating costs. Users are instructed to replace the DI module only when the module is near the end of its service life.

Storage tanks for purified water are an available option. We offer storage tanks ranging in capacity from 10L – 60L. Tanks of 25L or more have integrated pumps for fast and convenient dispensing. The dispensing flow rate is 4 L/min. All cartridges and filters are easy to access and replace. An integrated pump allows users to place the storage tank under a bench, if desired, to save space.

The Crystal 7 system has important safety functions, including:

- tank filling control
- tap water pressure control
- protection from tank sensor failure

The Crystal 7 systems include:

- boost pump
- pre-filter set
- reverse osmosis module
- deionization module

A UV-sterilization module is available as an option (P/N 10102).



Ordering Information

Model	Part number
Crystal 7 Pure	C7-1001
Crystal 7 RO	C7-1241



Storage tanks

Part number	Accessory	Crystal 7 RO	Crystal 7 Pure
11000	Storage tank "Basic" w/dispense pump, 25L	option	option
10007	Storage tank "Comfort" w/dispense pump, 60L	option	option
10004	Storage tank "Economy" w/dispense pump, 50L	option	option
11014	Storage tank "Tiny", 10L	option	option

Flow diagrams

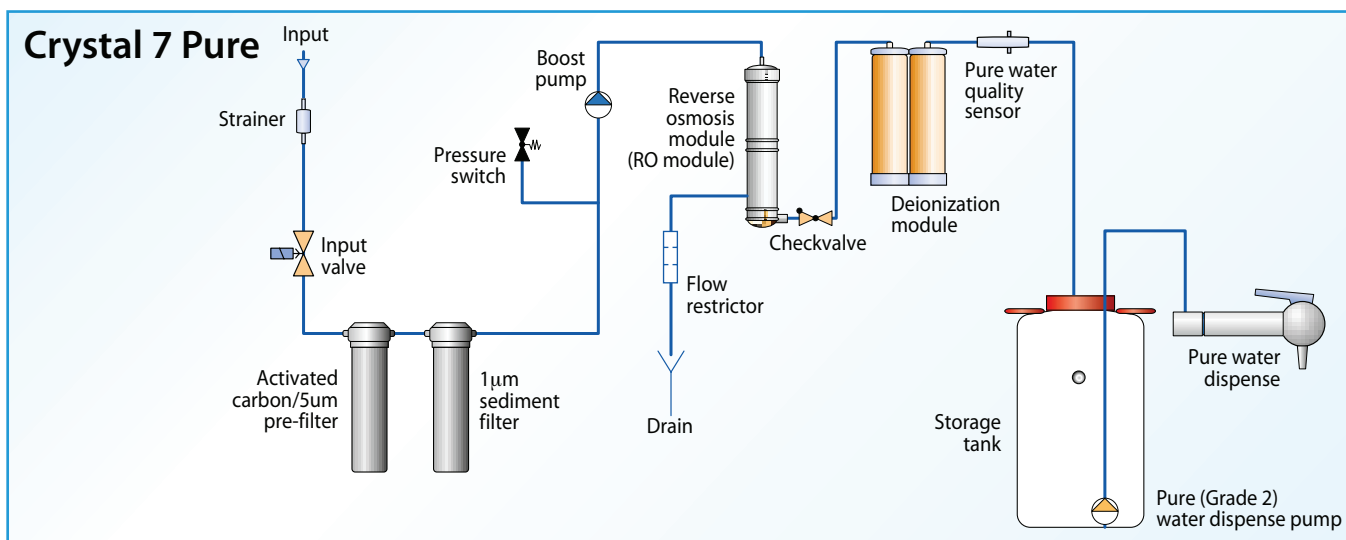
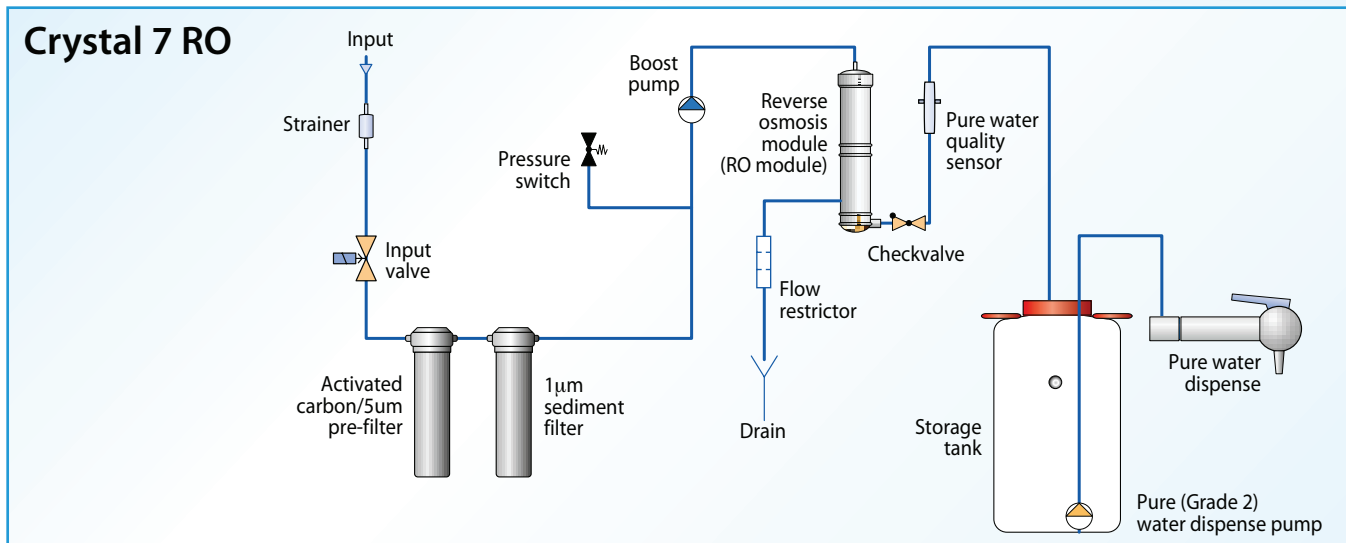

Applications

Application	Crystal 7 RO	Crystal 7 Pure
Glassware rinsing	●	●
Laboratory washers	●	●
Autoclaves	●	●
Electrochemistry	-	●
Flame AAS	-	●
Wet chemistry	-	●
Spectrophotometry	-	●
Buffer and media preparation	-	●

Components

Part number	Accessory	Crystal 7 RO	Crystal 7 Pure
10014	Pre-filter set for chlorine and organics reduction	+	+
	Boost pump	+	+
10015	Reverse osmosis module	+	+
	Deionization module pack	-	+
10102	UV sterilization module	-	option

Consumables

Part number	Description	Replacement criteria	Comments
10014	Replacement pre-filter set, Crystal 7	Filter life counter is zero or the filter is clogged	
10015	Replacement deionization module	„DI Err” message is shown, or water conductivity is consistently > 0.5 µS/cm	
10011	Replacement sterilization UV bulb	As required (on average every 3 years)	Systems with 10102 option only

PURE WATER SYSTEMS

Sterifeed

Sterifeed is a water purification system that is designed to produce feed water for autoclaves.

The Sterifeed system produces water with conductivity of 5-11 uS/cm. This is within the recommended conductivity range of 3-15 uS/cm, presented by autoclave manufacturers.

Water with a conductivity reading above 15 uS/cm facilitates salt deposits on heating elements, eventually leading to the failure of the heating element. Water with a conductivity below 3 uS/cm can attack internal surfaces of the autoclave, thusly damaging water level sensors, heating elements, and connections.

Sterifeed water provides optimal conductivity, within the range of 5-11 uS/cm, granting reliable operation of the autoclave.

A pressurized water storage tank provides a consistent water supply to the autoclave. Many autoclaves require a pressurized and purified water supply. Some autoclaves have priming pumps for purified water intake, but if the water supply is not pressurized, an air gap may block the water flow. If an air blockage occurs, the operation of autoclave is not possible until the air is removed from the system. The pressurized water storage tank of the Sterifeed system eliminates the formation of air gaps, and ensures reliable operation of the autoclave.

The Sterifeed system has an LCD display that provides information about the system status, water quality, and the remaining pre-filter life. The water softening module ensures long life of the purifying elements. These design features reduce the operational costs for your laboratory.

The Sterifeed comes with the necessary accessories for connection to an autoclave, and no tools are required!



Specifications

Purified water specifications	Sterifeed
Purified water resistivity	
Purified water conductivity	5-11 μ S/cm
Particles > 0.22 μ m	<1 per mL
Nominal flow, pure water (to storage tank)	10 L/h
Deionization module life	N/A
Recovery	>30 %
Dimensions (WxDxH), cm	50x20x52
Pressurized storage tank	60 L
Tanks' dimensions, cm	42x42x60
Feed water pressure	0.5 – 5 bar
Feed water conductivity	< 900 μ S/cm

Flow diagram

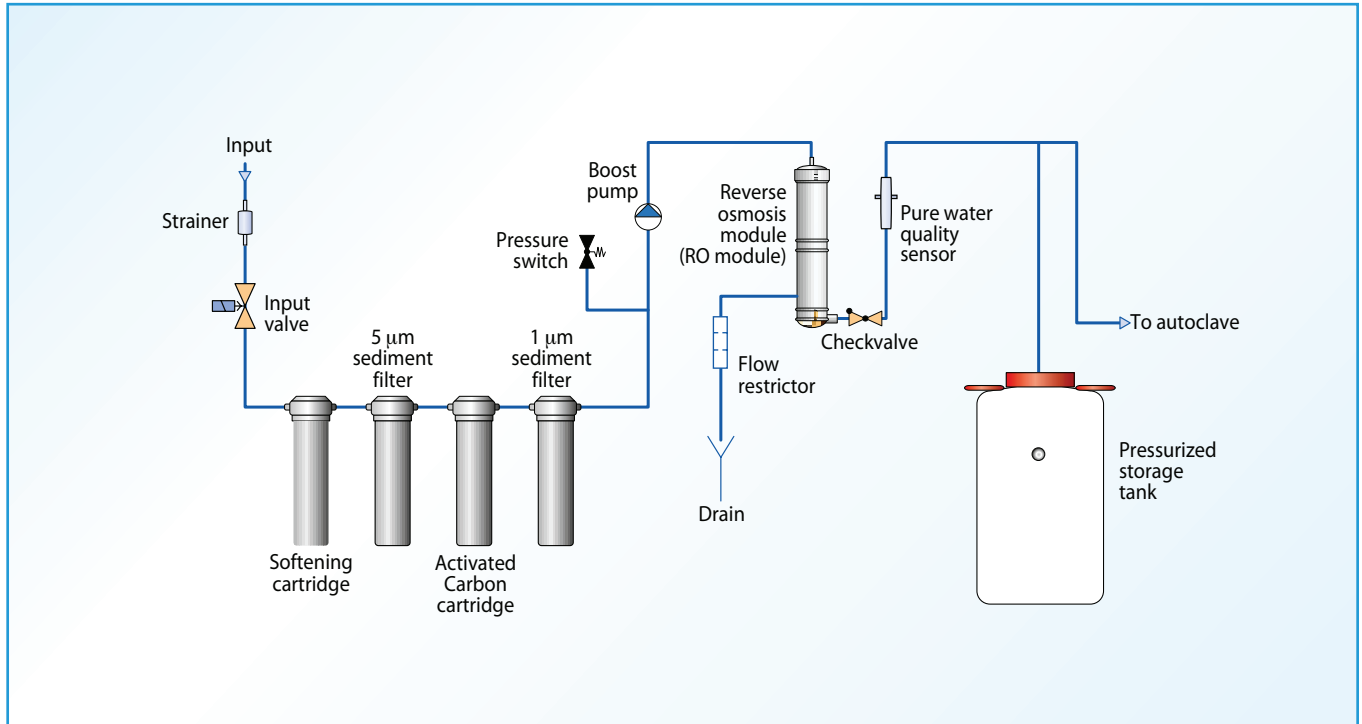

Consumables

Part number	Description	Replacement criteria	Comments
10016	Replacement pre-filter set, Sterifeed	Filter life counter is zero or the filter is clogged	

Ordering Information

Model	Part number
Crystal Sterifeed	CS-1002