

Dolphin

Liquid Ring Vacuum Pumps LX 0030/0055 B



Dolphin LX pumps are robust and proven liquid ring vacuum pumps from Busch in a compact block design. Their proven operating principle enables them to be used in all sectors of industry. This series encompasses the decades of experience in construction and use of liquid ring vacuum pumps. This means the Dolphin LX series offers extremely efficient and modern vacuum generation for the rough vacuum range up to 33 hPa (mbar) of ultimate pressure.

Application-oriented

Dolphin LX liquid ring vacuum pumps can be operated in simple circulating systems, in open or closed liquid cycles. Thanks to the precise grading between the sizes, the wide range of accessories and the versions of different materials, Dolphin LX pumps are perfectly suited to many industrial processes.

Even critical applications, such as the discharge of humid gases or vapours, can easily be carried out. Dolphin LX liquid ring vacuum pumps are also available in different ATEX versions.

Compact

A directly flange-mounted motor ensures an exceptionally compact construction, enabling Dolphin LX liquid ring vacuum pumps to be very well suited for integration into existing systems or machines.



Dolphin LX – Robust and compact. Ideal for difficult applications.



Dolphin

Liquid Ring Vacuum Pumps LX 0030/0055 B



Technical specifications

Dolphin LX pumps are single-stage liquid ring vacuum pumps. Normally water is being used as the operating fluid. An operation with other fluids is also possible, if required by the process conditions. An eccentrically mounted impeller wheel rotates within a housing. This housing is filled with water to the extent that the vanes of the impeller are immersed in the water. The rotary motion of the impeller wheel and the consequent centrifugal force cause the liquid in the housing to form the so-called liquid ring. The gas is conveyed in the spaces between the individual vanes and the liquid ring. Thanks to the eccentric arrangement of the impeller wheel, the volumes of these spaces change with the result that gas is sucked in, compressed and discharged again.

Accessories/technical options

- Liquid separator
- Cavitation protection
- Heat exchanger
- Gas ejector
- Non-return valves
- Drain valves
- Vacuum relief valves

Dolphin LX 0030/0055 B

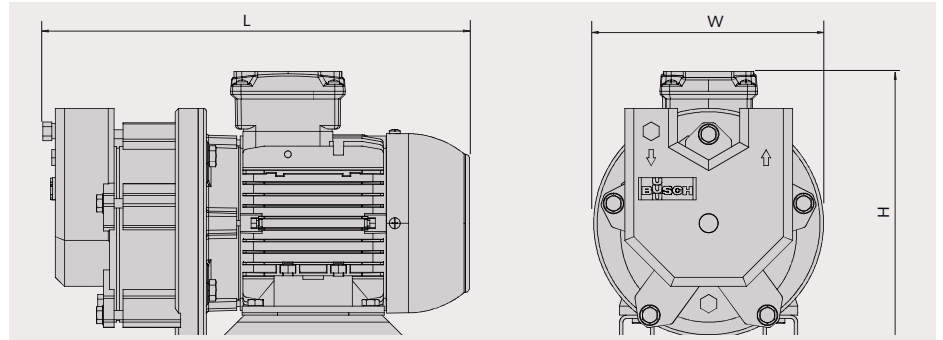

Pumping speed

Air at 20 °C. Tolerance: ± 10% — 50 Hz - - - - 60 Hz

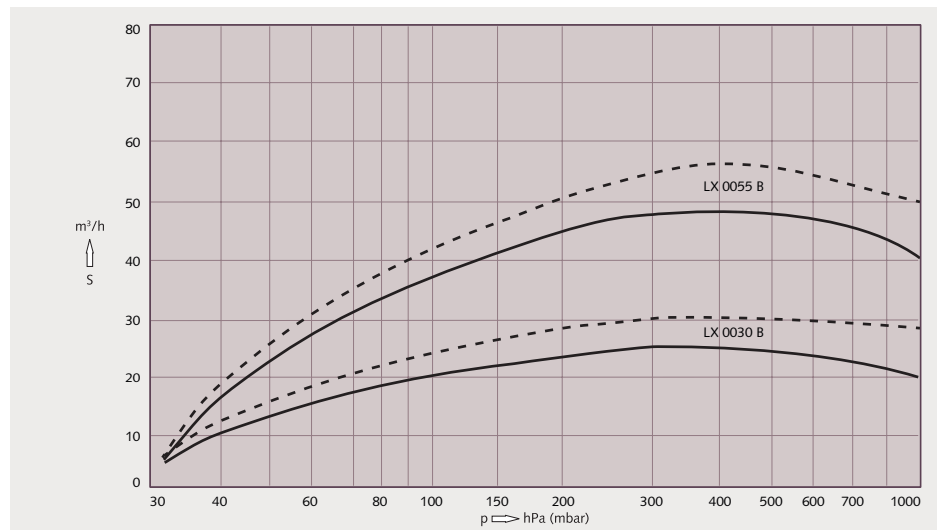

Technical Data			LX 0030 B	LX 0055 B
Nominal pumping speed	50 Hz / 60 Hz	m ³ /h	25 / 31	45 / 56
Ultimate pressure	50 Hz / 60 Hz	hPa (mbar)	33	33
Nominal motor rating	50 Hz / 60 Hz	kW	0.75 / 1.1	1.5 / 2.2
Nominal motor speed	50 Hz / 60 Hz	min ⁻¹	2900 / 3500	2900 / 3500
Noise level (ISO 2151)	50 Hz / 60 Hz	dB(A)	70	70
Weight approx.		kg	25	30 / 33
Dimensions	L x W x H	mm	361 x 200 x 242	430 x 200 x 255
Gas inlet / outlet		G	1" / 1"	1" / 1"

Busch Vacuum Kft.

Gyári út 23. | H-2310 Szigetszentmiklós | Phone +36 24 887 308 | busch@buschvacuum.hu | www.buschvacuum.hu

Argentina Australia Austria Belgium Brazil Canada Chile China Czech Republic Denmark Finland France Germany Hungary India Ireland Israel Italy Japan Korea Malaysia Mexico New Zealand Netherlands Norway Poland Portugal Russia Singapore South Africa Spain Sweden Switzerland Taiwan Thailand Turkey United Arab Emirates United Kingdom USA

Technical data is subject to change. Created in Germany 04/18