

# COBRA

Screw Vacuum Pumps  
NC 0100 - 0300 B



COBRA NC screw vacuum pumps are high-performance and robust vacuum generators for process technology, and they are being used wherever gases and vapours need to be pumped reliably and without contamination. Thanks to the dry screw technology, the compression chamber is completely free from operating fluids. This prevents condensation and deposits of the pumping medium and stops the medium from becoming contaminated with oil.

#### Ultimate pumping speed

COBRA NC screw vacuum pumps are designed to achieve a high, stable pumping speed – even at normal working pressure range of 1 to 100 hPa (mbar).

#### Operationally reliable

The asymmetrical screw profile and free gas discharge allow for a high degree of fluid and particle compatibility. Optimum corrosion resistance is ensured thanks to even temperature distribution. The outstanding levels of efficiency reduce the thermal demand and increase the life cycle.

#### Application-oriented

COBRA NC screw vacuum pumps are available in a range of application-specific versions, and can therefore be finely adjusted to suit any requirement. There are also a variety of ATEX-certified versions available. Contact us. Our application specialists are happy to advise you.



**COBRA NC – the robust and reliable solution for applications in medium and rough vacuum ranges.**

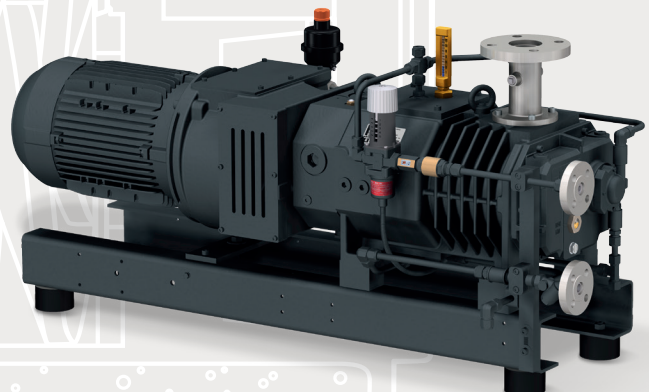

# COBRA

## Screw Vacuum Pumps NC 0100 - 0300 B



### Technical specifications

The COBRA NC is a one-stage, twin-screw vacuum pump. Two screw rotors are rotating inside the cylinder. The pumping medium is trapped between the individual screw coils, compressed and transported to the gas discharge. During the compression process, the two screw rotors do not come into contact with each other nor with the cylinder. There is no need for lubrication or an operating fluid in the compression chamber. Water cooling can take place in form of both direct water cooling or radiator cooling with air-cooled heat exchangers. Thanks to a wide range of technical options and accessories, COBRA NC screw vacuum pumps can be perfectly adjusted to suit every process. The complete series comprises seven sizes with nominal pumping speeds ranging from 100 up to 2,500 m<sup>3</sup>/h.

### Accessories/technical options

- Flushing gas supply
- Sealing gas supply
- Dilution gas supply
- Connection adapter to connect ISO or ASME flanges
- Non-return flap
- Exhaust gas silencer

### COBRA NC 0100-0300 B

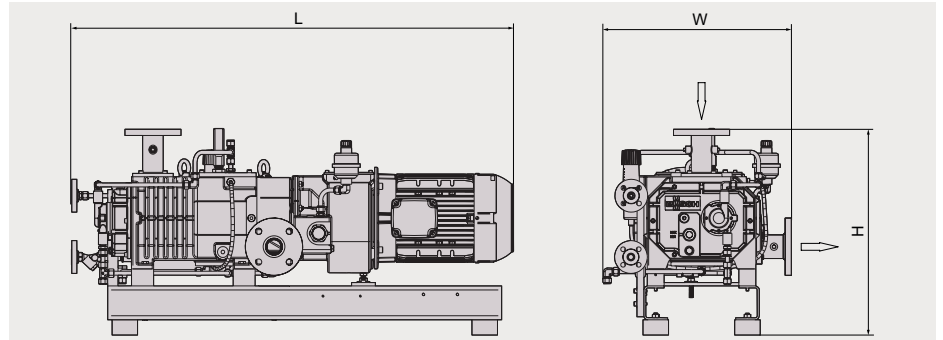

### Pumping speed

Air at 20 °C. Tolerance: ± 10% — 50 Hz - - - - 60 Hz

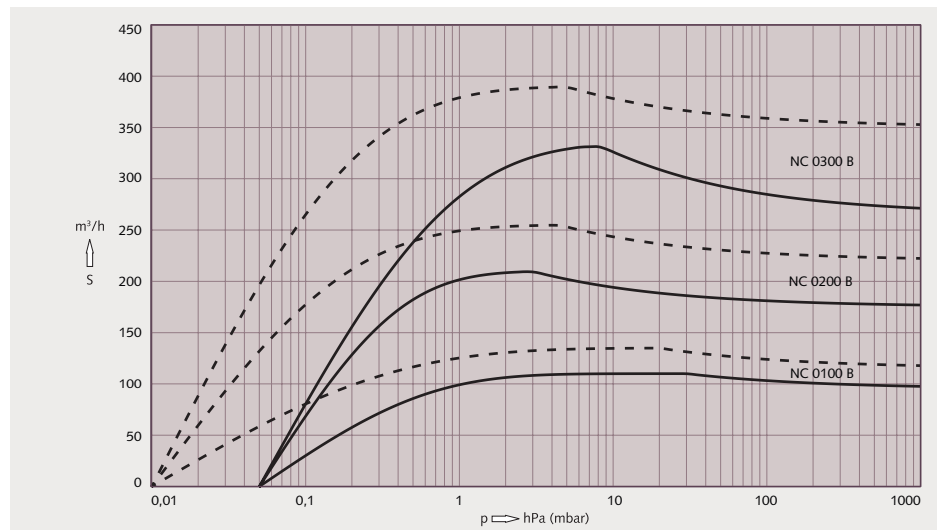

Technical Data			NC 0100 B	NC 0200 B	NC 0300 B
Nominal pumping speed	50 Hz / 60 Hz	m <sup>3</sup> /h	110 / 130	220 / 265	320 / 385
Ultimate pressure	50 Hz / 60 Hz	hPa (mbar)	≤ 0.05 / ≤ 0.01	≤ 0.05 / ≤ 0.01	≤ 0.05 / ≤ 0.01
Nominal motor rating	50 Hz / 60 Hz	kW	3.5 / 4.8	6.0 / 7.6	7.5 / 9.5
Nominal motor speed	50 Hz / 60 Hz	min <sup>-1</sup>	3000 / 3600	3000 / 3600	3000 / 3600
Noise level (ISO 2151)	50 Hz / 60 Hz	dB(A)	70 / 74	71 / 76	72 / 77
Weight approx.		kg	264	319	344
Dimensions	L x W x H	mm	957 x 520 x 914	1207 x 520 x 914	1279 x 520 x 914
Gas inlet / outlet			DN 40 PN 16 / DN 40 PN 16	DN 50 PN 16 / DN 50 PN 16	DN 50 PN 16 / DN 50 PN 16

### Busch Vacuum Kft.

Gyári út 23. | H-2310 Szigetszentmiklós | Phone +36 24 887 308 | busch@buschvacuum.hu | [www.buschvacuum.hu](http://www.buschvacuum.hu)

Argentina Australia Austria Belgium Brazil Canada Chile China Czech Republic Denmark Finland France Germany Hungary India Ireland Israel Italy Japan Korea Malaysia Mexico New Zealand Netherlands Norway Poland Portugal Russia Singapore South Africa Spain Sweden Switzerland Taiwan Thailand Turkey United Arab Emirates United Kingdom USA

Technical data is subject to change. Created in Germany 05/0