

4-way Reach truck 2.7 ton

BT reflex

F-series

FRE270

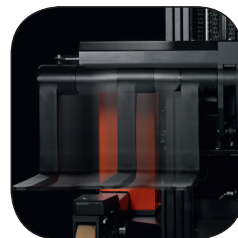

TOYOTA

MATERIAL HANDLING

stronger together

4-way Reach truck

Truck specifications						FRE270
Identification	1.1	Manufacturer				BT
	1.2	Model				FRE270
	1.3	Drive				Electric
	1.4	Operator type				Rider seated
	1.5	Load capacity/rated load	Q	kg		2700
	1.6	Load centre	c	mm		400 ¹⁾ /600 ²⁾
	1.8	Load distance, centre of drive axle to fork	x	mm		450
	1.9	Wheelbase	y	mm		1514
	Weight	2.1	Service weight including battery		kg	
2.3		Axle load, mast retracted without load, drive/support arm wheel		kg		3323/1351
2.4		Axle load, mast extended with load, drive/support arm wheel		kg		1366/6016
2.5		Axle load, mast retracted with load, drive/support arm wheel		kg		3360/4020
Wheels		3.1	Drive/fork wheel			
	3.2	Wheel size front (load end), load wheel/swivel castor				350x108 / 300x50 (2)
	3.3	Wheel size rear (driver end), drive wheel/swivel castor				350x128 / 230x65 (2)
	3.5	Wheels, number front/rear (x=driven wheels)				2/2 (1x)
	3.6	Track width, front (load end)	b ₁₀	mm		1560
	3.7	Track width, rear (driver end)	b ₁₁	mm		825
	Dimensions	4.1	Tilt of fork, forward/backward	α/β	deg	
4.2		Height, mast lowered	h ₁	mm		2950
4.3		Free lift	h ₂	mm		2087
4.4		Lift	h ₃	mm		6255
		Lift height	h ₂₃	mm		6300
4.5		Height, mast extended	h ₄	mm		7120
4.7		Height of overhead guard (cab)	h ₆	mm		2260
4.8		Seat height	h ₇	mm		1160
4.10		Height of support arms	h ₈	mm		480
4.15		Height of lowered forks	h ₁₃	mm		45
4.19		Overall length	l ₁	mm		2160*
4.20		Length to face of forks	l ₂	mm		1460
4.21		Overall width	b ₁	mm		1710
4.22		Fork dimensions	s/e/l	mm		45/100 ¹⁾ /1150, 45/125 ²⁾ /1150
4.25		Width over forks (fork adjustment min-max)	b ₅	mm		540/2220 ¹⁾ , 400/960 ²⁾
4.26		Distance between support arms (load surface)	b ₄	mm		1295
4.28		Reach distance	l ₄	mm		700
4.32		Ground clearance, centre of wheelbas	m ₂	mm		130
4.33		Aisle width for pallets 1000 x 1200 crossways	A _{st}	mm		2860
4.34		Aisle width for pallets 800 x 1200 lengthways	A _{st}	mm		3060
4.35	Turning radius	W _a	mm		1988	
4.37	Length over support arms	l ₇	mm		1960	
Performance data	5.1	Travel speed, with/without load		km/h		8,0/8,0
	5.2	Lift speed, with/without load		m/s		0,25/0,44
	5.3	Lowering speed, with/without load		m/s		0,33/0,38
	5.8	Max. gradeability, with/without load ⁴⁾		%		7/12
	5.10	Service brake				Electrical
Electric motor	6.1	Drive motor rating S2 60 min		kW		7,5
	6.2	Lift motor rating S3 15%		kW		14
	6.4	Battery voltage, nominal capacity K ₅		V/Ah		48/750
	6.5	Battery weight		kg		1150
	6.6	Energy consumption acc to VDI cycle ⁵⁾		kWh/h		
	Other	8.1	Type of drive control			
8.4		Sound level at the driver's ear according to EN 12 053		dB(A)		72

¹⁾ Type "a" fork spreader (spread 540-2220 mm)

²⁾ Type "b" fork spreader (spread 400-960 mm)

³⁾ Triplex mast 6300 mm lift height

⁴⁾ Measured according to company standard

⁵⁾ Contact your supplier for information

*) Depends on length of forks

All data are based on table configuration. Other configurations may give other values. Truck performance and dimensions are nominal and subject to tolerances. BT products and specifications are subject to change without notice.

Mast dimensions, mm

BT reflex

FRE270			Duplex Hi-Lo		Triplex Hi-Lo							
Lift height	h_{23}	mm	4150	4500	4800	5400	5700	6300	6700	7000	7500	8000
Lift	h_3	mm	4105	4455	4755	5355	5655	6255	6655	6955	7455	7955
FRE270	Height, mast lowered	h_1	2920	3100	2450	2650	2750	2950	3180	3280	3550	3710
	Free lift	h_2	2050	2230	1587	1787	1887	2087	2320	2420	2687	2853
	Height, mast extended	h_4	4980	5330	5620	6220	6520	7120	7520	7820	8330	8820

Fork spread type		Load center		Residual capacity		Lift height
FRE270		mm	400	600	kg	h_{23} mm
	Fork spread 540—2220 ("a")	mm	X		2700	5700
		mm	X		2200	8000
		mm		X	2250	5400
		mm		X	1700	8000
	Fork spread 400—960 ("b")	mm	X		2700	6300
		mm	X		2200	8000
		mm		X	2700	4500
mm			X	1700	8000	

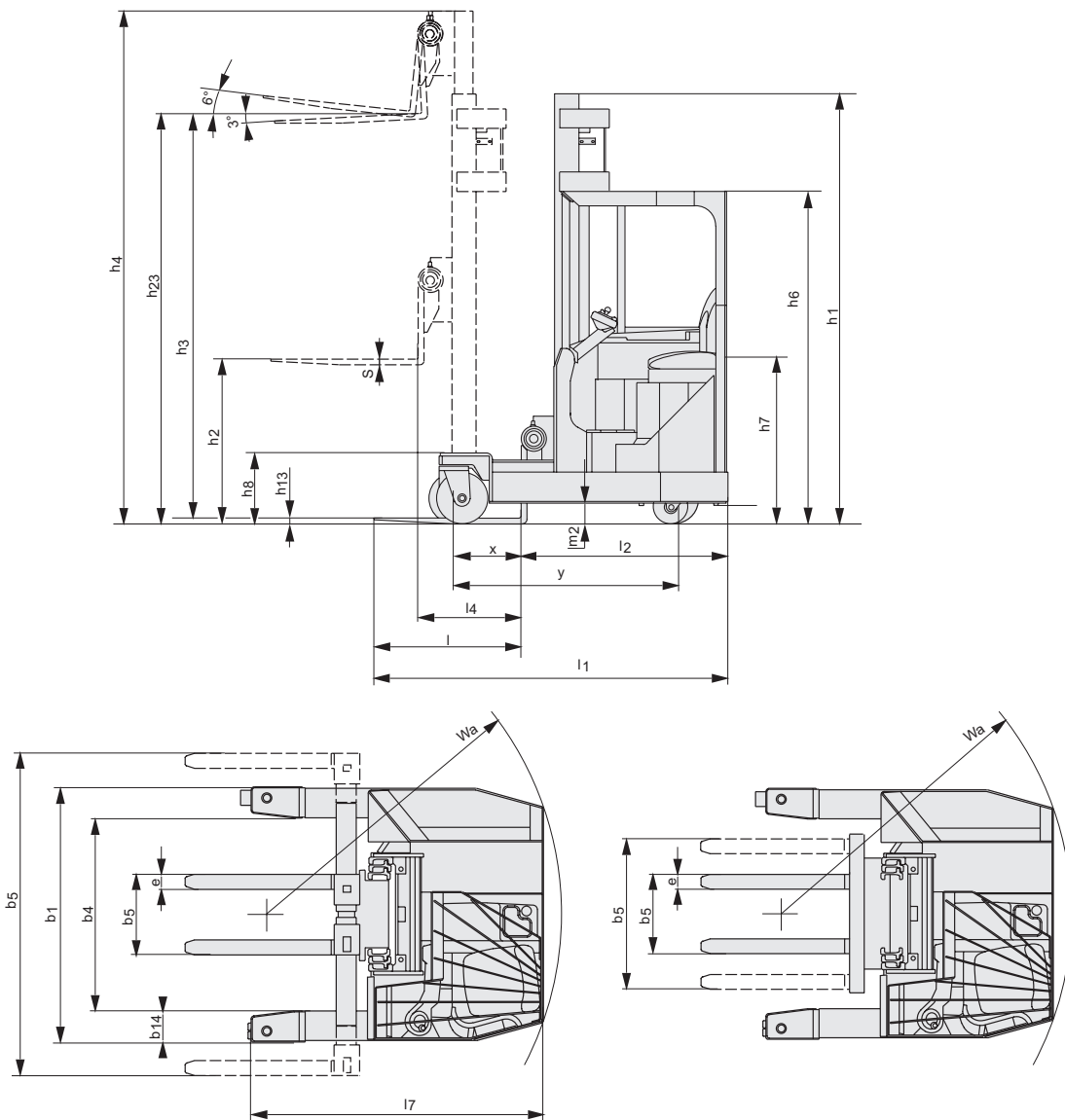

"a" Wide fork spread across support arms

"b" Thin fork spread between support arms

Truck features:

- 4-way, AC powered reach truck
- Four wheel truck for maximum stability
- Clear view mast: Duplex, and Triplex with fork tilt
- Hydraulic fork spreader as standard
- Ergonomic work place with front seated driver
- All hydraulic functions controlled by mini levers
- 360° steering for maximum maneuverability
- Steering direction indicator
- Automatic parking brake
- Battery on roller for easy horizontal battery change

