

# Towing truck 1.0-1.5 ton

## BT movit

*W-series*

TWE100N

TWE100

TWE150

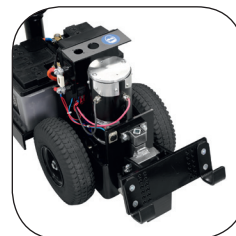

# Towing truck

Truck specifications					TWE100N	TWE150	TWE100
Identification	1.2	Model			TWE100N	TWE150	TWE100
	1.3	Drive			Electric	Electric	Electric
	1.4	Operator type			Hand	Hand	Hand
	1.5	Load capacity/rated load	Q	kg	1000	1500	1000
Weight	2.1	Service weight with battery		kg	68	99	99
	2.3	Axle load, drive wheel		kg	TBD	86	86
Wheels	3.1	Drive wheel			Pneumatic shaped cushion tyres		
	3.2	Wheel size, front		mm	Ø 260x85	Ø 260x85	Ø 260x85
	3.3	Wheel size, rear		mm	Ø 100x30	Ø 80x30	Ø 80x30
	3.5	Wheels, number front/rear (x=driven wheels)			2x/2	2x/2	2x/2
Dimensions	4.2	Height	$h_1$	mm	600	470	430
	4.9	Height of tiller arm, min./max.	$h_{14}$	mm	1000/1220	1030/1200	1030/1200
	4.19	Overall length	$l_1$	mm	640	760	760
	4.21	Overall width	$b_1$	mm	560	390	560
Perf. data	5.1	Travel speed with load		km/h	3,5	3,5	3,5
		without load		km/h	4,5	4,5	4,5
Motor	6.1	Drive motor		W	500	600	500
	6.4	Battery voltage, nominal capacity $K_5$		V/Ah	24/34	24/50	24/50
Other	8.1	Type of drive control			Stepless	Stepless	Stepless
		Gearbox			Differential gear	Worm gear	Differential gear

All data are based on table configuration. Other configurations may give other values.

Truck performance and dimensions are nominal and subject to tolerances.

Specifications are subject to change without notice.

# Dimensional drawings

## TWE100N

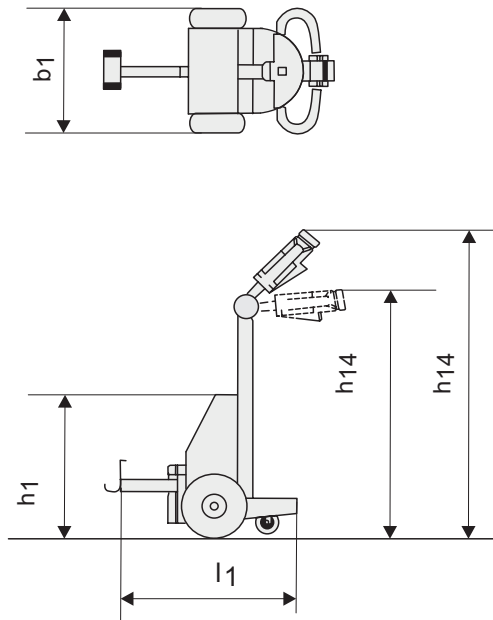

## TWE100

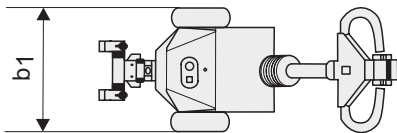

## TWE150

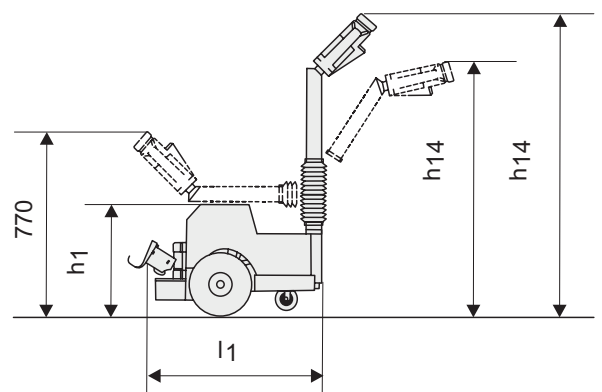
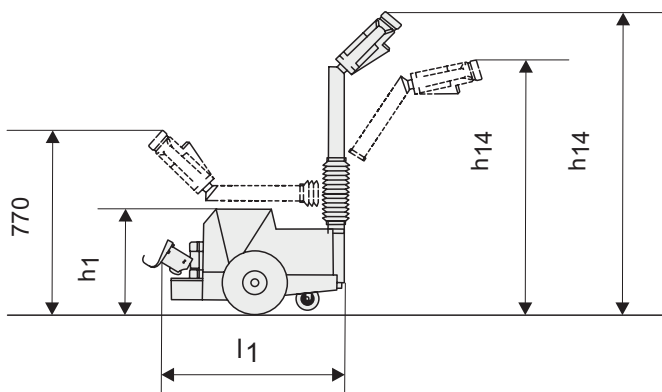
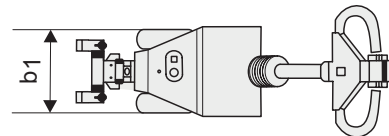

---

## Truck features:

- Compact towing truck
- Folding steering arm
- Non-marking tyres
- Variety of hooks
- Electronic drive control system
- Emergency switch
- Gel batteries (option)

