

OLYMPUS[®]

Your Vision, Our Future

Semiconductor/FPD/Industrial
Inspection Microscopes

MX Series

Higher Efficiency for Customers



Maximum User Efficiency

Olympus' first priority is the needs of our customers.

With this in mind, we deliver microscope solutions that make industrial inspection easier, quicker, and more efficient. At the same time, we address the ergonomics and wafer safety issues that come with successfully incorporating microscopes into a production line. Olympus is here to help, providing ideas, solutions, and support in applications including semiconductor wafers, flat-panel displays, and electronic devices.

MX61

Semiconductor wafer inspection microscope (up to 200 mm) enabling fast, accurate inspection via motorized aperture stop interlocked with objective lens. Ergonomic design delivers operator comfort. SEMI S2/S8 compliance ensures safety and reliability.



MX61L

Inspection microscope for large samples such as a 300 mm semiconductor wafer or 17-inch flat-panel display. Using clutch-driven manual XY stage, operator can move within 356 mm x 305 mm at reflected illumination and 356 mm x 284 mm at transmitted illumination.



MX61A

Motorized microscope for 300 mm samples. OLYMPUS Stream software enables motorized control of the observation mode, light intensity, objectives, aperture, and stage movement (optional). Active laser autofocus improves accuracy and speed of inspection.



MX51

Cost-effective microscope ensuring inspection of a variety of components and wafers (up to 150 mm). Focus/light intensity controls are close together so they can be operated with the same hand. SEMI S2/S8 compliance enhances safety and reliability.



MX61 Series—Semiconductor Wafer and Flat-Panel Inspection

Designed for Cleanroom Manufacturing Environments

Multiple Features Designed to Support Cleanroom Conformity

All motorized components are housed in a shielded structure and made of materials that offer excellent abrasion resistance and cleanroom conformity. Also the MX61 is capable of accommodating up to 200 mm wafers and the MX61L up to 300 mm wafers with the same small footprint to reduce space allocation.

Antistatic Protection Prevents Wafer Contamination

Antistatic processing is applied to the microscope frame, tube, breath shield, and other parts to prevent wafer contamination.



Antistatic breath shield

SEMI S2/S8 Compliance Ensures Safety and Reliability

The MX61 series comply in full with international specifications and standards such as SEMI S2/S8, CE, and UL.

Various Wafer Holders and Easy Adaptation for Different Sample Sizes

Users can select various types of 150-200 mm and 200-300 mm^{*1} wafer holders and glass plates. Should wafer sizes change on the production line, the frames can be modified at minimal cost. With the MX61, different stages can be used to accommodate 75 mm, 100 mm, 125 mm, and 150 mm wafers on the inspection line.

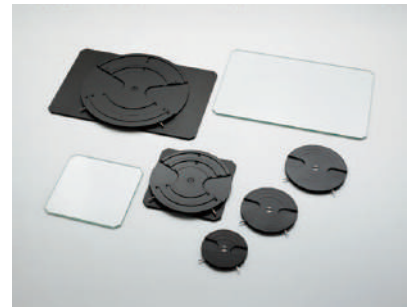

Wafer holders and glass plates

Safe, Quick Wafer Handling Improves Product Throughput^{*2}

An optional wafer loader can be attached to MX61 to safely transfer both silicon and compound semiconductor wafers from a cassette to the microscope stage without using tweezers. World-renowned performance and reliability for safe and efficient front and back macro inspections and microscope transfer improves yield and productivity within the fab while maintaining an ergonomic design.



MX61 combined with AL120 wafer loader (200 mm version)^{*3}

^{*1} MX61L/61A only ^{*2} MX61 only ^{*3} AL120 is not available in some areas. The AL120 is designed for use in industrial environments for the EMC performance. Using it in a residential environment may affect other equipment in the environment.

MX61 Series—Ergonomic Design

Easy, Comfortable and Safe to Operate

Ergonomic Controls for Quicker, More Comfortable Operation

Buttons for objective lens change and AS (aperture stop) adjustment are positioned low and in the front of the microscope. This allows for easy, comfortable operation and means that the user does not have to let go of the focusing knobs or move their head away from the eyepieces during use.

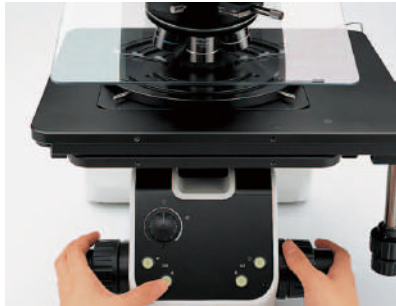

Centralized microscope operation

Clutch-Driven Manual XY Stages

Two high-precision stages are available: one that complies with wafers up to 300 mm and 17-inch panels, and one that complies with wafers up to 200 mm. The manual XY stage is capable of both coarse and fine stage movements by using the built-in clutch mechanism and XY knobs. Using the clutch, the operator can freely move the stage while performing inspections, increasing overall efficiency. This enables unrestricted stage movement while observing through the eyepiece and facilitates faster, more comfortable inspection.



Quick operation of stage grip with built-in clutch

Optimized Contrast through Automatic Aperture Control

The motorized AS is interlocked with the objective lens and automatically adjusts for the objective lens in use. Thus, image quality for every magnification is optimized, making routine inspections more comfortable for the eyes and more efficient for the operator.

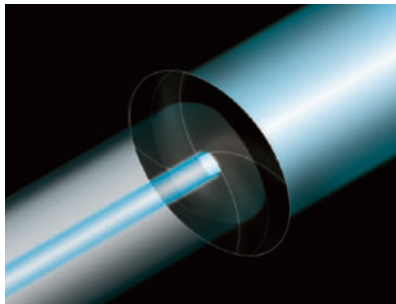

Powered aperture diaphragm

Increased Inspection Speed with Motorized Nosepieces

The rotational speed of the motorized nosepieces is faster and safer than manual nosepieces, decreasing time between inspections while maintaining cleanroom compatibility. Olympus offers three variations for desired inspection methods, controlled via software, frame button*, or independent handset.



Motorized nosepiece

Flexible Viewing Posture

Adjusting chair height or adopting an unnatural posture to suit the operator's view are just two of the many inconveniences that can slow down work speed. With this in mind, the MX61 series are equipped with a tilting observation tube that can be adjusted from 0° to 42° (variable height: 150 mm). This allows operators to find their most comfortable posture, regardless of physical differences, and also enables inspection while standing. In addition, the distance from optical axis to the eyepieces is long enough that even large stages can be easily operated.

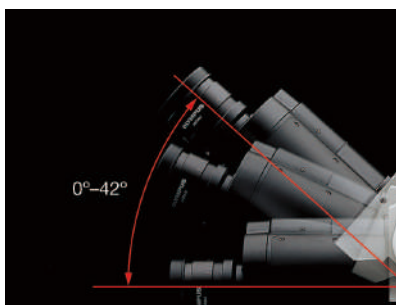

The tilting trinocular tube allows more comfortable posture.

Easy to Switch between Observation Methods

MX61/MX61L microscopes offer quick selection of observation mode via a single lever for brightfield and darkfield as well as an optional cube. In addition, MPLFLN-brightfield and darkfield series objective lenses require no positional prism switching in DIC observation. A transmitted light illumination unit can also be combined with both microscope frames to enable polarizing observation in transmitted light required for FPD inspections.



Observation method selection

* MX61/61L only

MX61 Series—Excellent Image Clarity and High Resolution

Optics Designed to Suit Your Specific Application

Advanced Optical Performance for Defect Detection

Olympus' advanced UIS2 optical system delivers high-contrast brightfield images for routine inspections and darkfield observation that enables quick detection of minute scratches that would previously have been overlooked in brightfield observation.

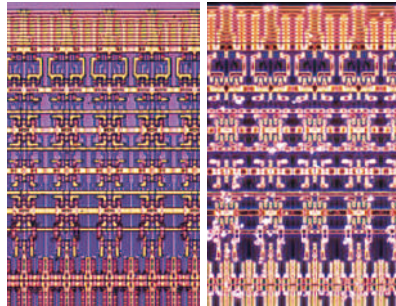

Brightfield image

Darkfield image

Optimized DIC Contrast for Different Surface Conditions Enhances Defect Detection

Three kinds of DIC prisms—standard, high-contrast, or high-resolution—can be selected according to surface irregularities and reflection characteristics of samples. This delivers images with optimized contrast and spatial effect, greatly improving defect detection ability.



Standard DIC
(Surface of hard disk)

High contrast DIC

Simultaneous Use of Reflected and Transmitted Light

Transmitted light can be added for photo-mask or FPD Inspections. Two types are available, one with a universal condenser and a second type with a high numerical aperture. Both support simple polarized light. Also, reflected light and transmitted light illumination systems can be used simultaneously, with independent intensity adjustment for each. This combination is ideal for inspection of semi-transparent devices.

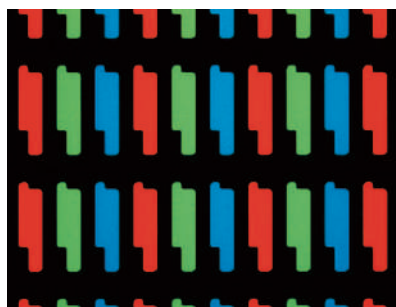

LCD panel/transmitted light image

Specialized Objectives

Olympus offers two series of objectives (LMPLFLN series and SLMPLN series) for applications that require an increased distance between the focal plane and the tip of the objective, typically required for samples with irregular topography, delicate structures, or mechanical constraints of the overall optical assembly. Objective lenses designed for specialized applications such as LCD inspection are also available (LCPLFLN-LCD series).



LCPLFLN-LCD series objective lenses

Fluorescence Observation

The MX61 series can be equipped with fluorescence observation by adding a mirror cube and high-intensity light source. Fluorescence observation is ideal for easy detection of resist residuals and organic particles.

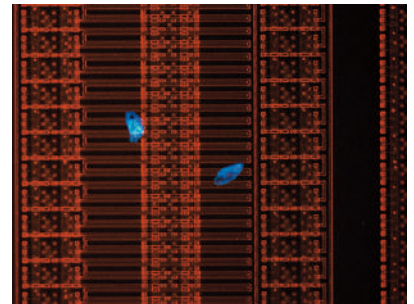

Particles on wafer

Near-infrared (IR) Observation

Olympus' specialized objectives are designed for near-infrared (IR) imaging of features and defects beneath the surface of silicon and glass. The semiconductor and photovoltaic industries use IR imaging for alignment, identification of sub-surface contamination, and critical dimension inspections. These optics employ a higher NA that improves both the resolution and brightness of the IR image. Additionally, 20x, 50x, and 100x objectives are designed with a correction collar that corrects for the aberrations caused by the thickness of silicon and glass, improving overall contrast. (LMPLN-IR series and LCPLN-IR series)

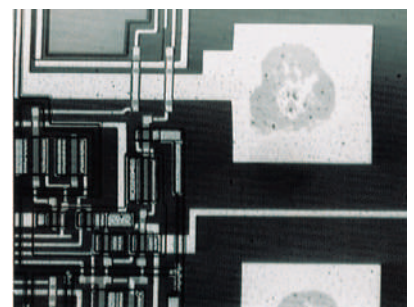

Bonding pad from the back side of wafer

MX61A—Automated Solutions Meeting Demands for Automation

Portfolio of Motorized Controls

The MX61A offers following motorized controls:

- Observation mode
- Z Focus
- Objective magnification
- Aperture stop
- Light intensity
- Hardware autofocus (optional)
- DIC prism adjustment (optional)
- Scanning stage controls (optional)

OLYMPUS Stream software controls basic microscope operations such as live image preview and image capture while also allowing more complex operations like autofocus and DIC prism adjustment via PC screen.

Active Laser Autofocus

The MX61A is equipped with an active laser autofocus unit that improves the accuracy and speed of inspections. The multi-spot sensor enables a substantial increase in stability by eliminating the effects of vertical topography on the sample providing even faster and more repeatable results.

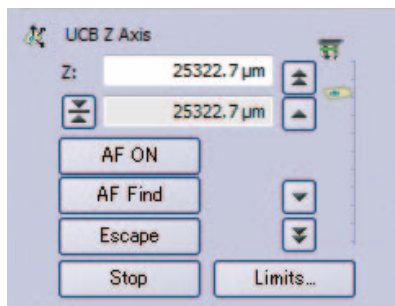

Easy-to-use autofocus control

Advanced Software Integration

In combination with 200 mm or 300 mm motorized scanning stages, OLYMPUS Stream enables the operator to easily stitch various images beyond a single view, furthering image acquisition and analysis possibilities.

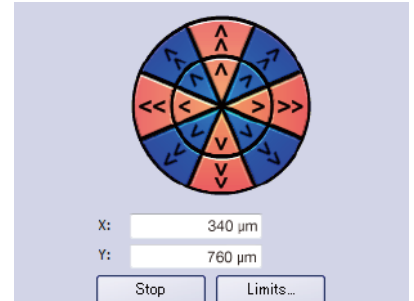

Intuitive control of motorized stage

Handset for Tactile Control

An ergonomically designed handset allows push-button control for the motorized functions of the microscope such as selecting the objective lens and observation techniques. The operator can also switch between TRACE and ONE SHOT control of the autofocus unit, manually fine-focus, adjust the retardation position in DIC, control lamp intensity, and lower the stage for sample exchange.



Key-touch operation with handset

MX51 — Electronic Device Inspection Designed for Electronic Device Manufacturing Environments

ESD (Electrostatic Discharge)

Antistatic coatings on the MX51 frame and 150 mm stage can quickly eliminate static electricity preventing the sample under observation from electrostatic damage. The microscope can be fully upgraded to an ESD protection type.

SEMI S2/S8 Compliance Enhances Safety and Ergonomics

The MX51 complies with international industry standards to guarantee superior reliability.

Expandability for Thick Samples

As electronic devices continue to become more diversified, more samples with varied sizes are needed for observation. Standard maximum sample thickness is 30 mm; by inserting an intermediate attachment, thicker samples can also be accommodated (custom-made specifications).



Flexible structure for thicker sample

MX51 — Easy Operation

Faster Detection Ensures Quicker, More Productive Throughput

Intuitive Stage Design

Two stage sizes are available: 150 mm and 100 mm. The 150 mm stage has a built-in clutch lever that enables quick coarse/fine stage positioning to locate samples on the stage without diverting the operator's view, reducing operator fatigue.

Ergonomic Controls

Focus and light intensity controls are close together and toward the front of the microscope so that both can be operated with the same hand.



Ergonomic design and quick stage operation

Coded Revolving Nosepieces Provide Objective Information Onscreen

Using a coded revolving nosepiece, objective magnification can be displayed within the OLYMPUS Stream software system or directly onscreen with a standalone camera. This allows you to monitor the magnification during observation and record that magnification with the image. This convenient feature is available with a manual coded nosepiece.



Coded revolving nosepieces and control unit

Motorized Revolving Nosepieces Enable Direct Change of Objective Lenses

The MX51 can be equipped with a range of motorized nosepieces. An external handset allows direct selection of the desired objective lens or it can also be controlled using OLYMPUS Stream. The MX51 also offers a centerable motorized nosepiece for highly accurate positioning (recommended for high magnifications).

MX51 — Optimum Optical Quality for Failure Analysis

Detection of Minute Flaws through Multiple Observation Methods

Advanced UIS2 Optical System Provide Accurate Defect Detection

Fast detection of defects and fewer inspection failures are ensured through brighter brightfield and darkfield observation, with detection sensitivity improved over the entire MX Series. High accuracy is delivered in the observation of small-diameter wafers such as those used in today's smaller sensors and other high-performance electronic devices.

Multiple Observation Methods from Visible to Fluorescence and Near-IR

The standard illuminator (BX-RLA2) facilitates near-IR observation and also offers brightfield, darkfield, DIC, and simple polarizing observation. A universal illuminator (BX-URA2) is also available for fluorescence observation.

Transmitted Light Observation

The combination of a transmitted illumination unit with the 150 mm stage enables transmitted light brightfield observation of samples up to 2 mm thick, with a transmitted illumination envelope of 100 mm x 100 mm. The slim-profile illumination unit is designed for minimal effect on stage operation and is useful for inspection of samples such as MEMS (Micro-Electro-Mechanical Systems) sensors and other optical/optoelectronic components.



Transmitted illumination module

Passionate about Imaging

Olympus Digital Cameras Capture the Images You Need

Sophisticated Camera Portfolio

Modern microscopy requires an extensive range of sensors—Olympus offers a sophisticated portfolio of digital cameras that covers a wide range of materials science applications both today and tomorrow. Our sensor lineup ranges from cameras for documentation purposes to cooled high-performance, high-sensitivity cameras for advanced image analysis applications. All cameras are designed to deliver optimal digital imaging performance with Olympus microscopes and imaging analysis software systems.



Broad range of digital cameras

Universal Model

High resolution, high sensitivity and high-speed data transfer in any illumination mode, outstanding operational ease with real-time image viewing and color fidelity

Standard Model

Balanced solutions for general documentation and image processing, this range of Olympus standard cameras give you a choice when it comes to matching your digital imaging requirements and budget

Introductory Model

Designed for brightfield applications and simple digital documentation purposes, with a favorable cost/performance ratio

Gray Scale Model

Highly sensitive monochromatic sensor that provides a spectral response and fits for thin, through-silicon near IR imaging

Standalone Model

A compact solution for imaging and documentation when bench space is limited (no PC required)

Keep Your Workflow Streamlined

OLYMPUS Stream Software Adapts to Your Every Requirement

Intuitive Operation, Precise Results

OLYMPUS Stream image analysis software allows you to seamlessly acquire images, process and measure them, and create a flexible database. And because your time is just as important as your working conditions, OLYMPUS Stream can be personalized to fit your process flow without changing your operation. An easy-to-use interface guides you effortlessly through every step, from image adjustment and capture to measurements, reporting, and archiving—or whatever else you need to achieve. As a result, you can complete tasks more efficiently, regardless of their complexity.

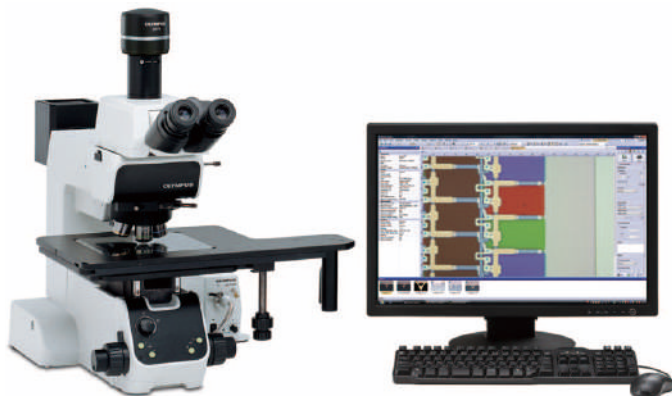

High performance imaging system with MX61

From Simple Measurement to Advanced Analysis

Measurement is essential to quality control and inspection. With this in mind, even the entry-level OLYMPUS Stream package includes a full menu of interactive measurement functions, with all measurement results saved with image files for further documentation. In addition, the OLYMPUS Stream Materials Solutions offer an intuitive, workflow-oriented interface for complex image analysis. At the click of a button, image analysis tasks can be executed quickly and precisely. With a significant reduction in processing time for repeated tasks, operators can concentrate on inspection at hand.

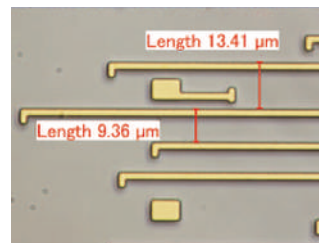

Line distance with Basic measurement

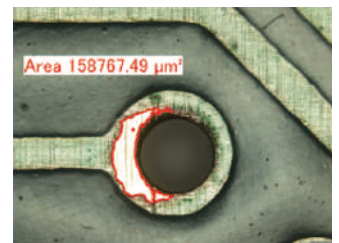

Area definition with Magic wand function

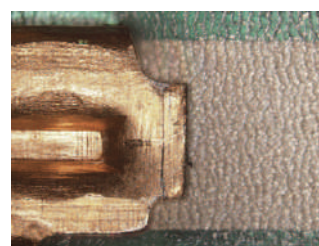

Extended focus image (EFI) of a crimped terminal

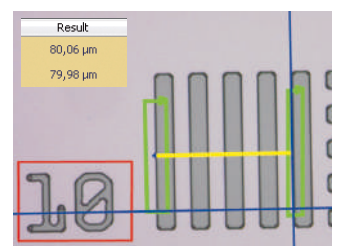

Automated measurement by pattern recognition

MX61/61L System Diagram

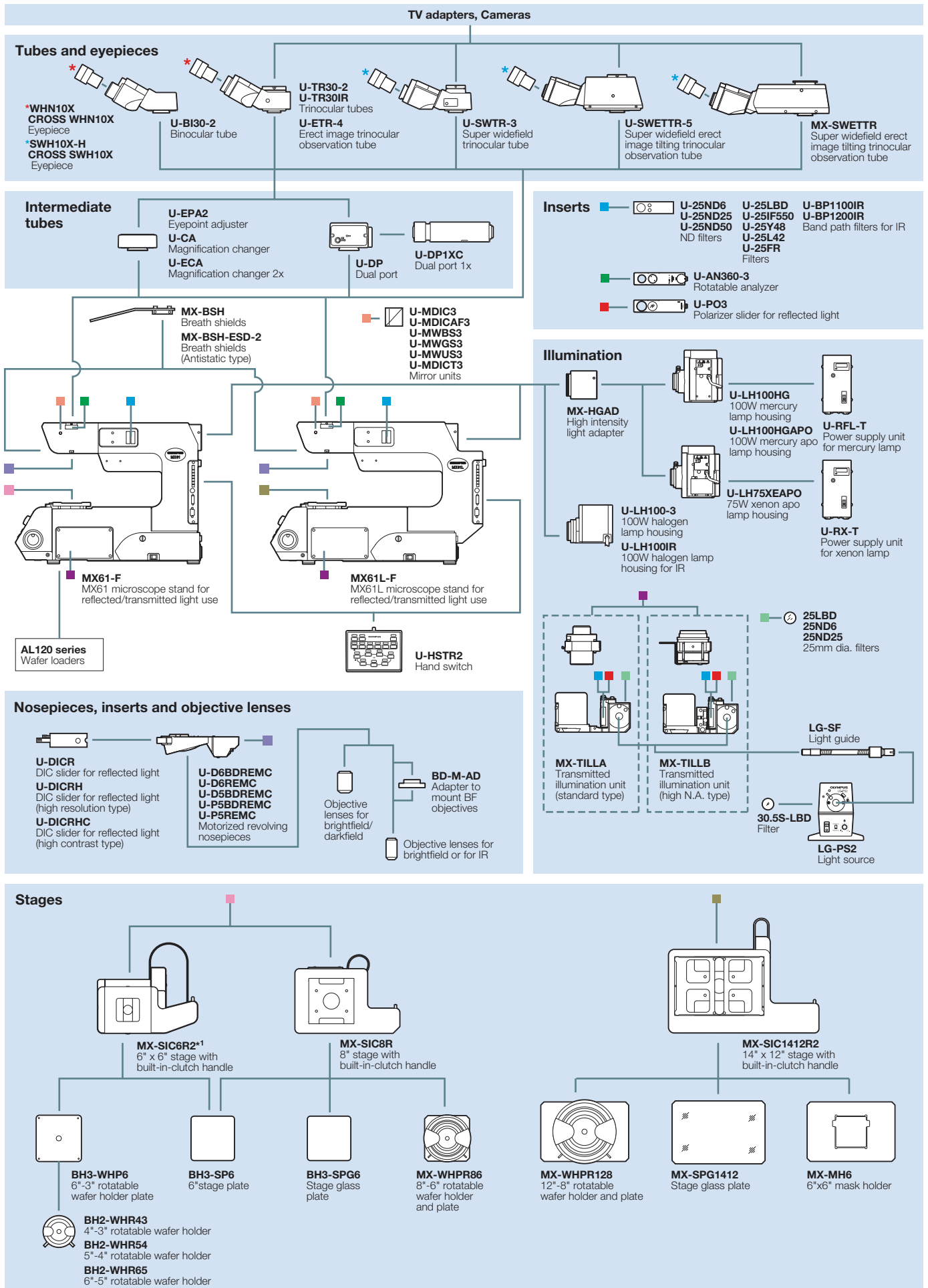

*1 Reflected light use only

MX61A System Diagram

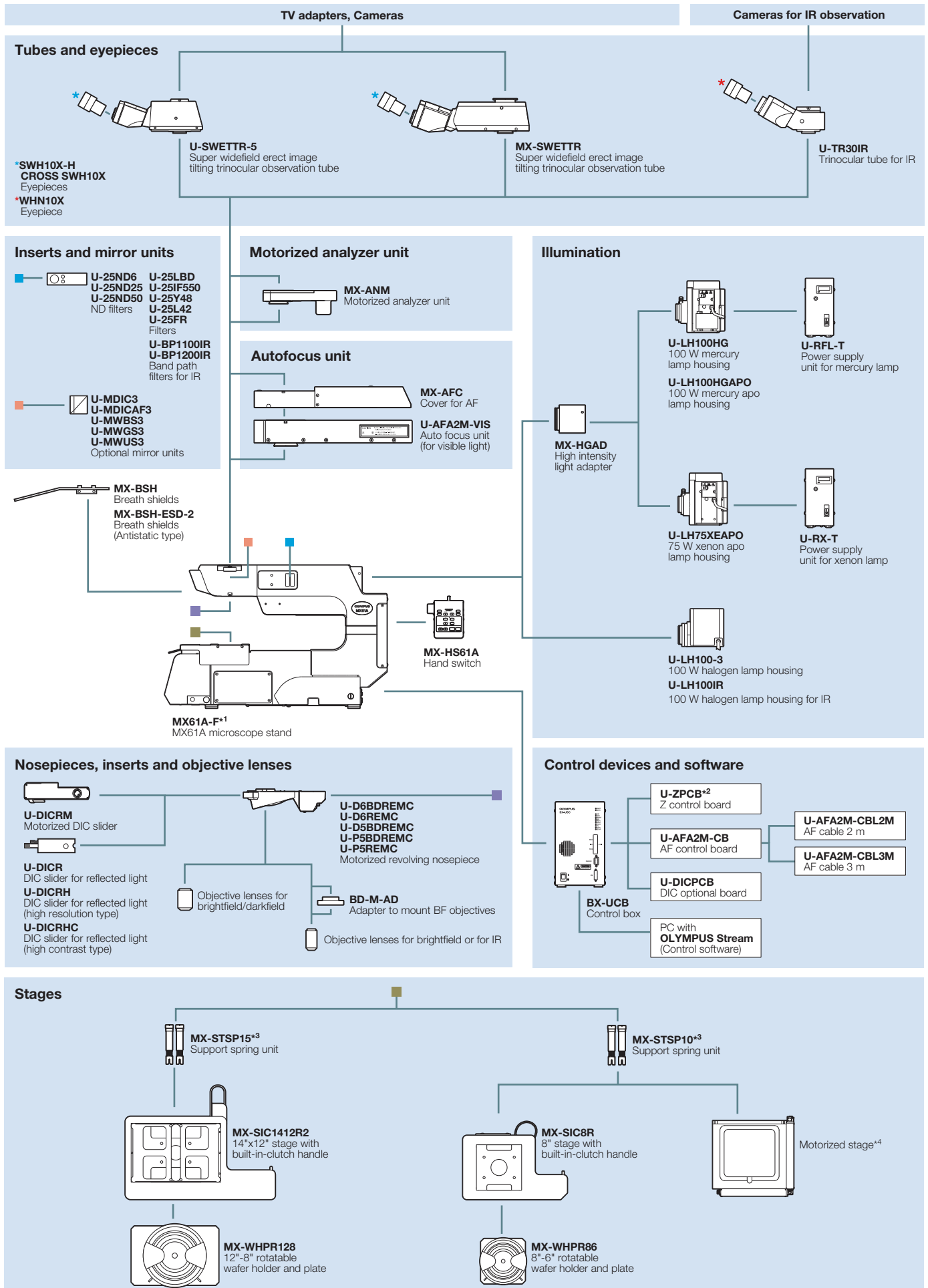

*1 The transmitted light module is available on a special order basis. *2 Required in the non autofocus configuration. *3 Maximum weight to load on focusing MX-STSP10: 10 kg, MX-STSP15: 15kg
 *4 Local purchase item. A support spring unit is required.

MX51 System Diagram

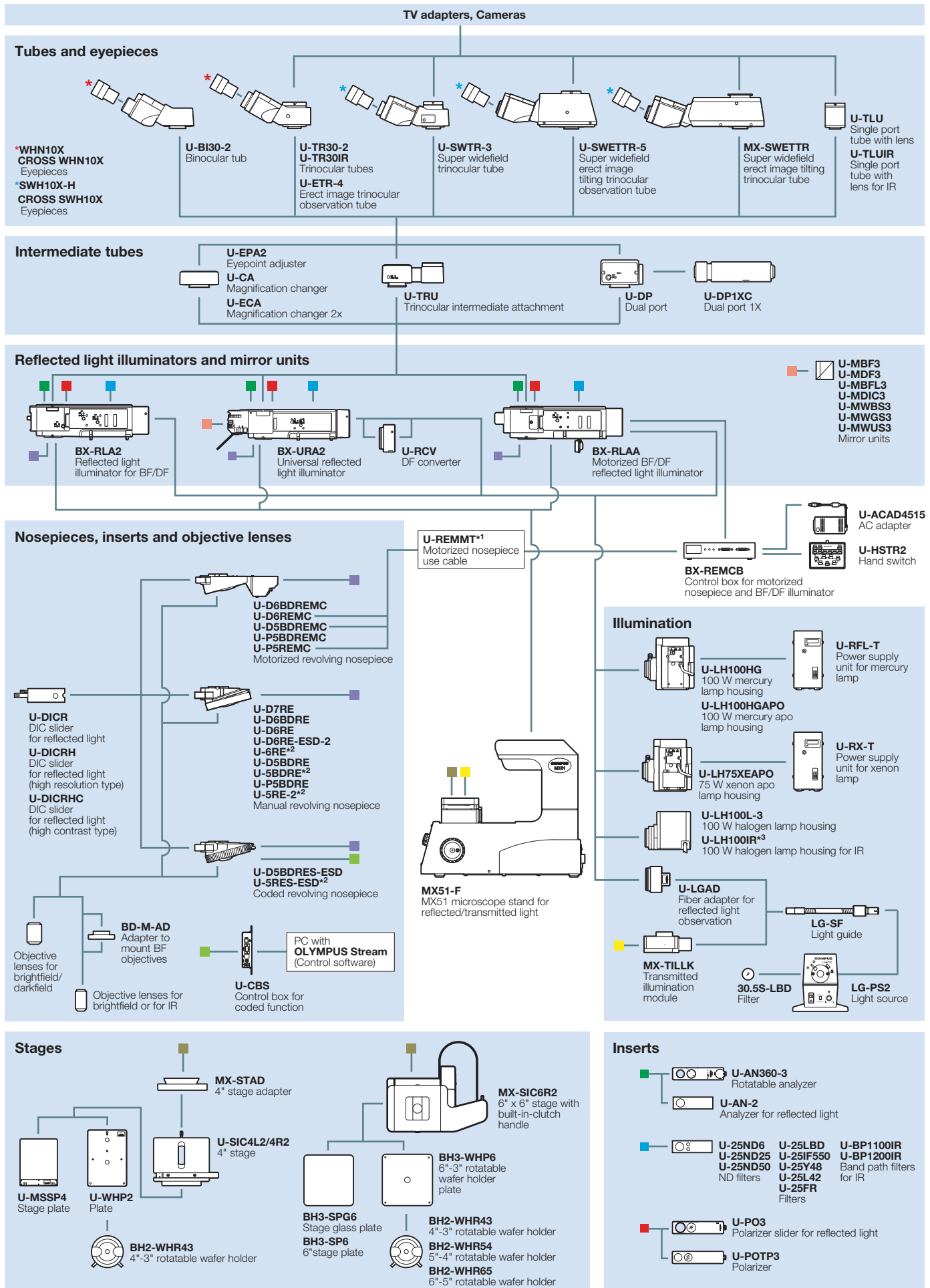

*1 This cable is required for BX-RLA2 or BX-URA2 combination. *2 DIC slider is not available. *3 Extended cable U-RMT is required

Specifications

MX61/MX61L SPECIFICATIONS

		MX61	MX61L
Optical system		UIS2 optical system (infinity-corrected system)	
Microscope frame	Illumination	Reflected light illumination (F.N. 26.5) 12 V 100 W halogen lamp Brightfield/darkfield/mirror cube manual changeover. (Mirror cube is optional.) Built-in motorized aperture diaphragm (Pre-setting for each objective lens, automatically full open for darkfield) Observation mode: brightfield, darkfield, differential interface contrast (DIC)*1, simple polarizing*1, fluorescence*1 and infra-red*1 *1 Optional mirror cube Transmitted light illumination (F.N. 26.5) Transmitted light illumination unit MX-TILLA or MX-TILLB is required. Transmitted light illumination unit with a condenser (N.A. 0.5) and an aperture stop: MX-TILLA Transmitted light illumination unit with a condenser (N.A. 0.6), an aperture stop and a field stop: MX-TILLB Light source: LG-PS2 (12 V, 100 W halogen lamp) Light guide: LG-SF Observation mode: brightfield, simple polarizing	
	Focus	Stroke: 32 mm Fine stroke per rotation: 100 µm Minimum graduation: 1 µm Upper limit stopper and torque adjustment for coarse handle	
Maximum load weight (including stage and holder)		8 kg	15 kg
Electrical system		Reflected light illumination Built-in electronic power supply for reflected light illumination (12 V 100 W) Continuously-variable light intensity dial Input rating 100-120 V/220-240 V AC 1.9/0.9A, 50Hz/60Hz Transmitted light illumination Light source LG-PS2 (12 V 100 W) Continuously-variable light intensity dial Input rating 100-120V/220-240V AC 3.0/1.8A 50/60Hz External interface Motorized revolving nosepiece connector x1, Handset (U-HSTR2) x1, 8-pin I/O connector x1, RS232 connector x1	
Observation tube	Super widefield (F.N. 26.5)	Elect, tilting and trinocular: MX-SWETTR (optical path switchover 100% (eyepiece) : 0 (camera) or 0 : 100%) Elect, tilting and trinocular: U-SWETTR (optical path switchover 100% (eyepiece) : 0 (camera) or 20% : 80%) Inverted and trinocular: U-SWTR-3	
	Widefield (F.N. 22)	Elect and trinocular: U-ETR4 Inverted and trinocular: U-TR30-2, U-TR30IR (for IR observation) Inverted and binocular: U-BI30-2,	
Revolving nosepiece	Brightfield and darkfield	Motorized sextuple with a slider slot for DIC: U-D6BDREMC Motorized quintuple with a slider slot for DIC: U-D5BDREMC Motorized centerable quintuple with a slider slot for DIC: U-P5BDREMC	
	Brightfield	Motorized sextuple with a slider slot for DIC: U-D6REMC Motorized centerable quintuple with a slider slot for DIC: U-P5REMC	
Stage		Coaxial right handle with built-in clutch drive: MX-SIC8R Stroke: 210 x 210 mm Transmitted light illumination area: 189 x 189 mm	Coaxial right handle with built-in clutch drive: MX-SIC1412R2 Stroke: 356 x 305 mm Transmitted light illumination area: 356 x 284 mm
Weight		Approx. 40 kg (microscope frame only: approx. 27kg)	Approx. 51 kg (microscope frame only: approx. 31kg)

MX61A SPECIFICATIONS

Optical system		UIS2 optical system (infinity-corrected system)
Microscope frame	Illumination	Reflected light illumination (F.N. 26.5) 12 V 100 W halogen lamp Brightfield/darkfield/mirror cube motorized changeover (Mirror cube is optional.) Built-in motorized aperture diaphragm (Pre-setting for each objective lens, automatically full open for darkfield) Observation mode: brightfield, darkfield, differential interface contrast (DIC)*1, simple polarizing*1, fluorescence*1 and infra-red*1 *1 Optional mirror cube
	Motorized focus	Stroke: 25.4 mm Fine adjustment sensitivity: 1.2 µm or less Resolution: 0.01 µm Maximum speed: 5 mm/sec (Default: 3mm/sec)
	Maximum load weight (including stage and holders)	10 kg (equipped with MX-STSP10), 15 kg (equipped with MX-STSP15)
	Electrical system	Control box BX-UCB (12 V 100 W) Input rating 100-120 V/220-240 V AC 3.5/1.5A, 50Hz/60Hz
Observation tube	Super widefield (F.N. 26.5)	Elect, tilting and trinocular: MX-SWETTR (optical path switchover 100% (eyepiece) : 0 (camera) or 0 : 100%) Elect, tilting and trinocular: U-SWETTR (optical path switchover 100% (eyepiece) : (camera) or 20% : 80%)
	Widefield (F.N. 22)	Inverted and trinocular for Infra-red observation: U-TR30IR (optical path switchover eyepiece:camera 100%: 0 or 0 : 100%)
Revolving nosepiece	Brightfield and darkfield	Motorized sextuple with a slider slot for DIC: U-D6BDREMC Motorized quintuple with a slider slot for DIC: U-D5BDREMC Motorized centering quintuple with a slider slot for DIC: U-P5BDREMC
	Brightfield	Motorized sextuple with a slider slot for DIC: U-D6REMC Motorized centering quintuple with a slider slot for DIC: U-P5REMC
Stage	Manual	Coaxial right handle with built-in clutch drive: MX-SIC1412R2 Stroke: 356 x 305 mm Coaxial right handle with built-in clutch drive: MX-SIC8R Stroke: 210 x 210 mm
	Motorized	Please contact Olympus dealers in your area.
Controller	Handset	MX-HS61A Operational functions are as follows. : objective lens change, light intensity adjustment, fine/coarse focus, observation mode switchover, DIC prism position adjustment, autofocus ON/OFF, autofocus TRACE/ONE SHOT, retraction of stage
	Software	Image analysis software OLYMPUS Stream Please refer to OLYMPUS Stream brochure. (PC is required.)
Active laser autofocus (option)		Auto focus unit: U-AFA2M-VIS Pupil-division reflection active auto focusing using a laser diode and 2-division detector. Multi-spot projection Laser wave length: 785 nm (Class I: IEC60825, CDRH, JIS C6802) Tracking range (pro form amount)*2 5x: ±5000 µm and more 10x: ±2000 µm, 20x: ±1100 µm, 50x: ±400 µm, 100x: ±100 µm, *2 The tracking range depends on the sample reflectivity and objective lens in use.
Weight		Approx. 56 kg (microscope frame only approx. 31kg)

•This product is designed for use in industrial environments for the EMC performance. Using it in a residential environment may affect other equipment in the environment.

MX51 SPECIFICATIONS

Optical system		UIS2 optical system (infinity-corrected system)
Microscope frame	Focus	Stroke: 32 mm (17mm for transmitted light illumination combination) Fine stroke per rotation: 100 µm Minimum graduation: 1 µm Upper limit stopper and torque adjustment for coarse handle
	Electrical system	Input rating 100-200/220-240V AC 1.8/08A 50/60Hz Continuously-variable light intensity dial
Reflected light observation		Reflected light illuminator for BF/DF : BX-RLA2 Observation mode: brightfield, darkfield Built-in brightfield/darkfield switchover Universal reflected light illuminator: BX-URA2 Observation mode: brightfield, darkfield, differential interface contrast (DIC), simple polarizing, fluorescence and infra-red Observation mode selection: mirror cube by turret system. Up to six cubes are equipped with the turret system.
Transmitted light observation		Transmitted light illumination unit: MX-TILLK Light source: LG-PS2 (12 V 100 W halogen lamp) Light guide: LG-SF Manual stage MX-SIC6R2 is required. Observation mode: brightfield
Observation tube	Super widefield (F.N. 26.5)	Elect, tilting and trinocular: MX-SWETTR (optical path switchover 100% (eyepiece) : 0 (camera) or 0 : 100%) Elect, tilting and trinocular: U-SWETTR (optical path switchover 100% (eyepiece) : 0 (camera) or 20% : 80%) Inverted and trinocular: U-SWTR-3
	Widefield (F.N. 22)	Elect and trinocular: U-ETR4 Inverted and trinocular: U-TR30-2, U-TR30IR (for IR observation) Inverted and binocular: U-BI30-2,
Revolving nosepiece	Brightfield and darkfield	Sextuple with slider slot for DIC: U-D6BDRE Quintuple with slider slot for DIC: U-D5BDRE, U-D5BDRES-ESD (Coded, Control unit U-CBS is required.) Quintuple: U-5BDRE Center able quintuple with slider slot for DIC: U-P5BDRE
	Brightfield	Septuple with slider slot for DIC: U-D7RE Sextuple with slider slot for DIC: U-D6RE Quintuple with slider slot for DIC: U-D5RE-ESD-2 Sextuple: U-6RE Quintuple: U-5RE-2, U-5RES-ESD (Coded, Control unit U-CBS is required.) Centerable quintuple: U-P5REM
Stage	Manual	Coaxial right handle with built-in clutch drive: MX-SIC6R2 Stroke: 158 x 158 mm Transmitted light illumination area: 100 x 100 mm Coaxial right/left handle: U-SIC4R2/SIC4L2 Stroke: 100 x 105 mm
	Weight	Approx. 26 kg (microscope frame only: 11kg)

UIS2 OBJECTIVE LENSES SPECIFICATIONS

Objective Lenses	Magnifications	Numerical Aperture (N.A.)	Working Distance (W.D.) (mm)	Cover Glass Thickness* ¹ (mm)	Silicon Thickness (mm)	Resolution* ² (μm)
MPLAPON	50x	0.95	0.35	0	—	0.35
	100x	0.95	0.35	0	—	0.35
	100xOil* ³	1.4	0.1	0	—	0.24
MPLFLN	1.25x* ^{4,5}	0.04	3.5	—	—	8.39
	2.5x* ⁵	0.08	10.7	—	—	4.19
	5x	0.15	20.0	—	—	2.24
	10x	0.30	11.0	—	—	1.12
	20x	0.45	3.1	0	—	0.75
	40x* ⁶	0.75	0.63	0	—	0.45
	50x	0.80	1.0	0	—	0.42
	100x	0.90	1.0	0	—	0.37
MPLFLN-BD*⁷	5x	0.15	12.0	—	—	2.24
	10x	0.30	6.5	—	—	1.12
	20x	0.45	3.0	0	—	0.75
	50x	0.80	1.0	0	—	0.42
	100x	0.90	1.0	0	—	0.37
	150x	0.90	1.0	0	—	0.37
MPLFLN-BDP*⁷	5x	0.15	12.0	—	—	2.24
	10x	0.25	6.5	—	—	1.34
	20x	0.40	3.0	0	—	0.84
	50x	0.75	1.0	0	—	0.45
	100x	0.90	1.0	0	—	0.37
SLMPLN	20x	0.25	25	—	—	1.34
	50x	0.35	18	0	—	0.96
	100x	0.6	7.6	0	—	0.56
LMPLFLN	5x	0.13	22.5	—	—	2.58
	10x	0.25	21.0	—	—	1.34
	20x	0.40	12.0	0	—	0.84
	50x	0.50	10.6	0	—	0.67
	100x	0.80	3.4	0	—	0.42
LMPLFLN-BD*⁷	5x	0.13	15.0	—	—	2.58
	10x	0.25	10.0	—	—	1.34
	20x	0.40	12.0	0	—	0.84
	50x	0.50	10.6	0	—	0.67
	100x	0.80	3.3	0	—	0.42
MPLN*⁴	5x	0.10	20.0	—	—	3.36
	10x	0.25	10.6	—	—	1.34
	20x	0.40	1.3	0	—	0.84
	50x	0.75	0.38	0	—	0.45
	100x	0.90	0.21	0	—	0.37
MPLN-BD*^{4,7,8}	5x	0.10	12.0	—	—	3.36
	10x	0.25	6.5	—	—	1.34
	20x	0.40	1.3	0	—	0.84
	50x	0.75	0.38	0	—	0.45
	100x	0.90	0.21	0	—	0.37
LCPLFLN-LCD	20x	0.45	8.3–7.4	0–1.2	—	0.75
	50x	0.70	3.0–2.2	0–1.2	—	0.48
	100x	0.85	1.2–0.9	0–0.7	—	0.39
LMPLN-IR*⁴	5x	0.1	23	—	—	6.71* ⁹
	10x	0.3	18	—	—	2.24* ⁹
LCPLN-IR*⁴	20x	0.45	8.3	0–1.2	0–1.2	1.49* ⁹
	50x	0.65	4.5	0–1.2	0–1.2	1.03* ⁹
	100x	0.85	1.2	0–0.7	0–1.0	0.79* ⁹

*¹ — : Applicable to the view of samples with/without a cover glass.

0 : Applicable to the view of samples without a cover glass.

*² Resolutions calculated with aperture iris diaphragm wide open.

*³ Specified oil: IMMOIL-F30CC.

*⁴ Limited up to F.N. 22. No compliance with F.N. 26.5.

*⁵ Analyzer and polarizer are recommended to the usage with MPLFLN1.25x or 2.5x.

*⁶ The MPLFLN40x objective lens is not compatible with the differential interference contrast microscopy.

*⁷ "BD" : "Brightfield/darkfield" objective lenses.

*⁸ Slight vignetting may occur in the periphery of the field when MPLN-BD series objective lenses are used with high-intensity light source such as mercury and xenon for darkfield observation.

*⁹ With the use of 1100 nm.

Dimensions

MX61

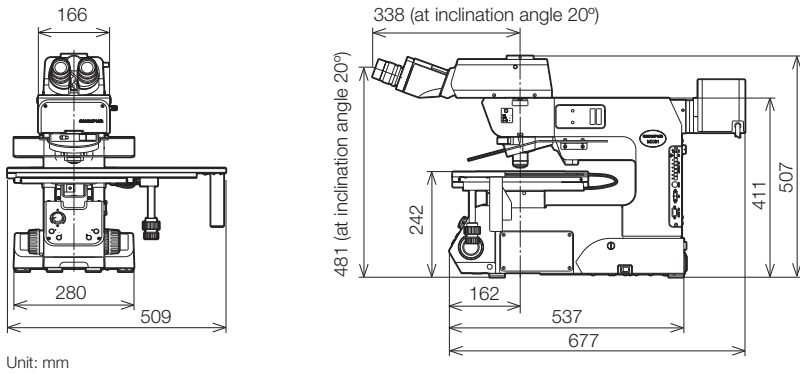

Unit: mm

MX61L

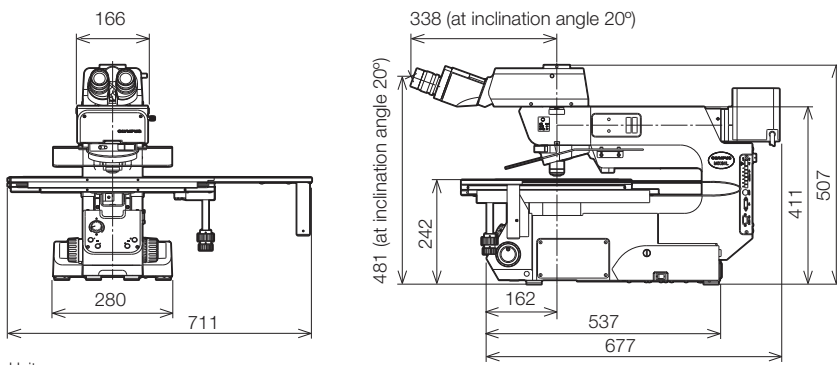

Unit: mm

MX61A (MX61A, autofocus unit, manual stage)

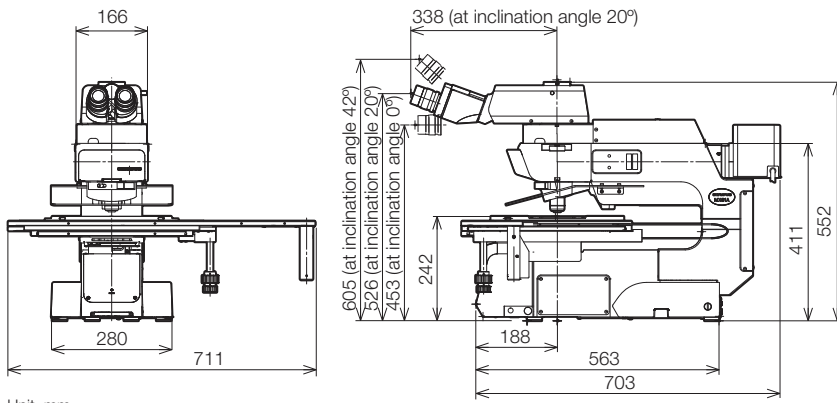

Unit: mm

MX-HS61A

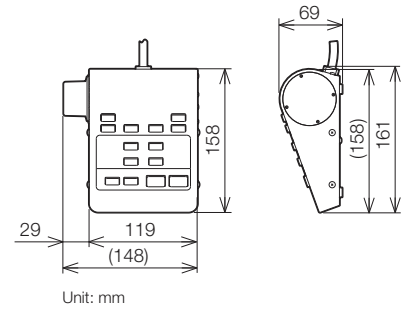

Unit: mm

MX51

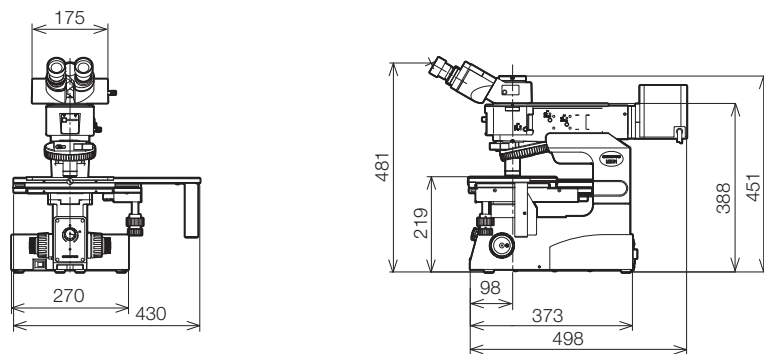

Unit: mm

www.olympus-ims.com

OLYMPUS[®]

For enquiries - contact
www.olympus-ims.com/contact-us

OLYMPUS CORPORATION
Shinjuku Monolith, 2-3-1, Nishi-Shinjuku, Shinjuku-ku, Tokyo 163-0914, Japan
OLYMPUS EUROPA SE & CO. KG
Wendenstrasse 14-18, 20097 Hamburg, Germany
OLYMPUS SCIENTIFIC SOLUTIONS AMERICAS CORP.
48 Woerd Avenue, Waltham, MA 02453, U.S.A.

OLYMPUS (CHINA) CO., LTD.
10F, K. Wah Centre, 1010 Huai Hai Road (M), Xuhui District, Shanghai, 200031 P.R.C.
OLYMPUS KOREA CO., LTD.
8F Olympus Tower, 446 Bongeunsa-ro, Gangnam-gu, Seoul, 135-509 Korea
OLYMPUS AUSTRALIA PTY. LTD.
3 Acacia Place, Notting Hill VIC 3168, Australia

- **OLYMPUS CORPORATION is ISO9001/ISO14001 certified.**
- **Illumination devices for microscope have suggested lifetimes. Periodic inspections are required. Please visit our web site for details.**
- All company and product names are registered trademarks and/or trademarks of their respective owners.
- Specifications and appearances are subject to change without any notice or obligation on the part of the manufacturer.