

OLYMPUS[®]

Your Vision, Our Future

3D Measuring Laser Microscope

OLS4100

LEXT

Bringing Answers to the Surface



Precise measurement. Faster operation. High-quality imaging.

Expanding the Boundaries of Laser Microscopy

Measurements and images you can count on. Every time.



LEXT OLS4100

Widely used in quality control, research, and development across an array of industries and applications, OLYMPUS LEXT 3D measuring laser microscopes have set new standards in 3D laser microscopy. Now, as demand grows for increased measurement precision and wider observation applicability, Olympus has responded with the new LEXT OLS4100. Designed to facilitate faster, easier measurement and higher-quality imaging, the OLS4100 is expanding the boundaries of laser microscopy.

The new OLYMPUS LEXT OLS4100. Going beyond the borders of possibility.

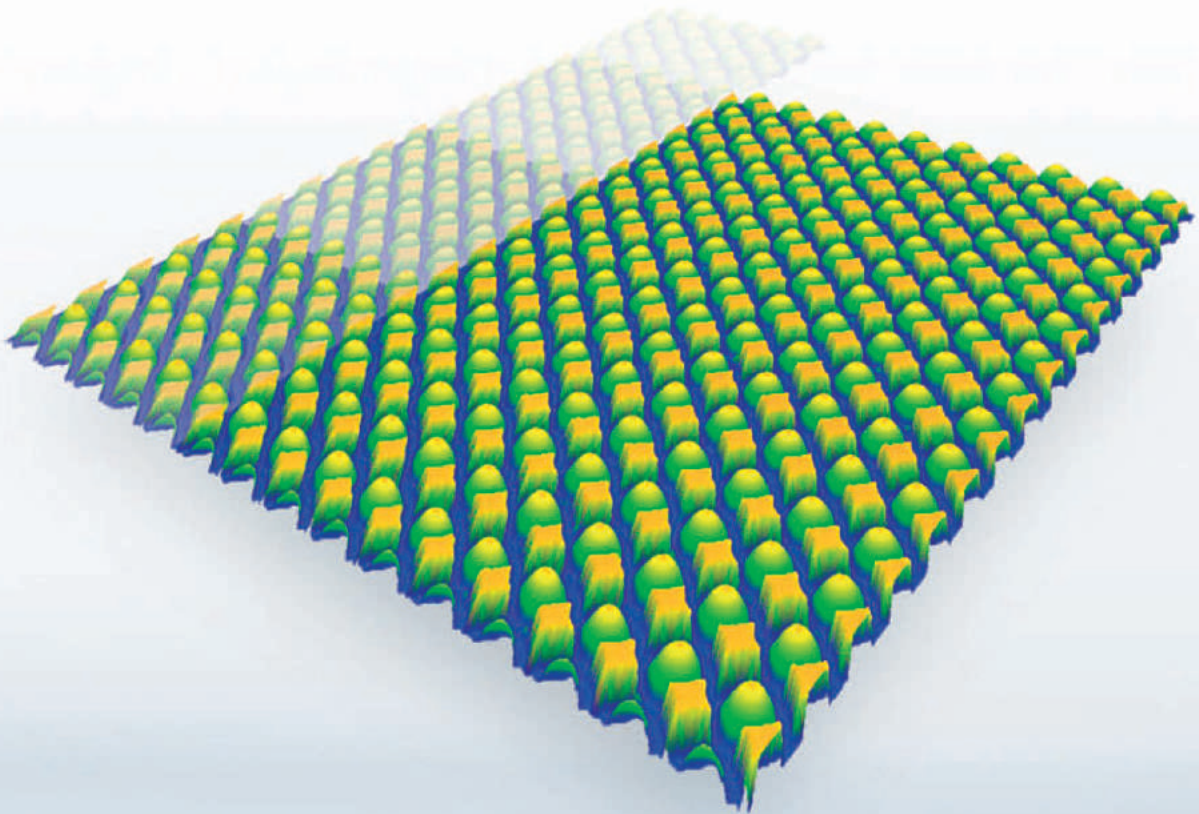

Contents

Advantages of Laser Scanning Microscopes	4
Superior Metrology	6
High-Quality Imaging	12
Systematic Workflow via Intuitive GUI	16
Basic Principles of the LEXT OLS4100	22
Sample Applications	24

Advantages of Laser Scanning Microscopes

Fast Non-Contact, Non-Destructive Imaging and Measurement

Non-Contact, Non-Destructive Measurement

Unlike stylus-based contact-type surface roughness gauges, laser scanning microscopes (LSMs) employ a low-power light that will prevent damaging the surface.

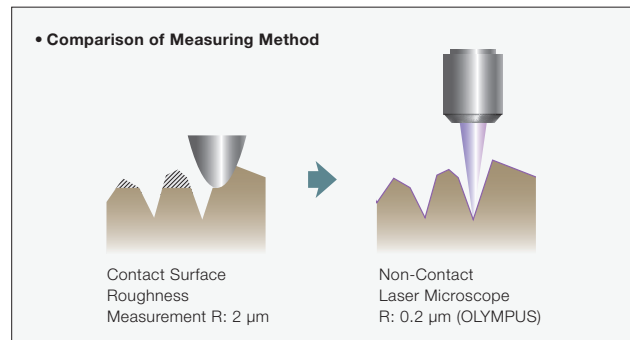

Imaging Without Sample Preparation

A scanning electron microscope (SEM) requires extensive sample preparation such as vacuum evaporation and/or altering the sample to fit in the observation chamber. An LSM allows the measurement of samples without any prior preparation, and immediate imaging after placing the sample on the stage.

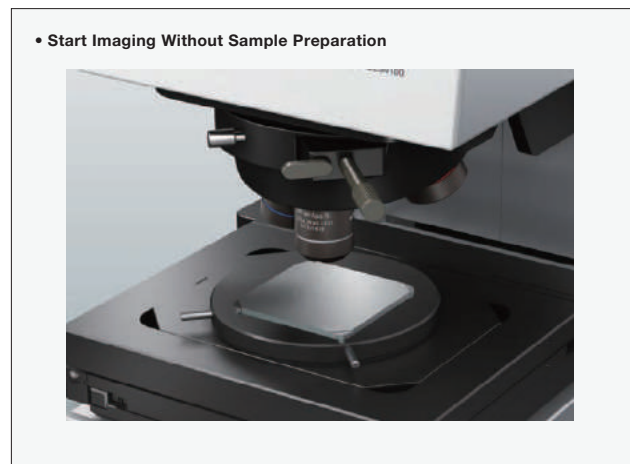

LSM Solution for	
SEM Samples	Roughness Gauge Samples

With an LSM, the sample can be safely returned to the production line or experiment thanks to non-destructive measurement.

Superior X-Y-Axis Measurement

Accurate Measurement of Submicron Distances Across the X-Y Axes

An interferometer is based on a normal white-light optical microscope, and so achieves the same lateral resolution. With a larger-aperture objective and reduced wavelength, the resolution of an LSM is greatly improved over typical white light microscopes. In addition, precise angular-controlled movement of the laser focus means that an LSM can perform accurate X-Y plane sub-micron measurements on diverse types of samples. The OLS4100 achieves a lateral resolution of 0.12 microns.

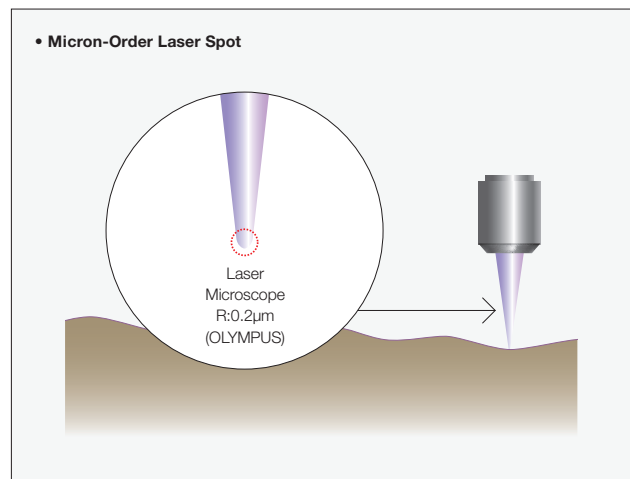

• **Angular-Controlled Laser Scanning for High-Resolution Imaging**

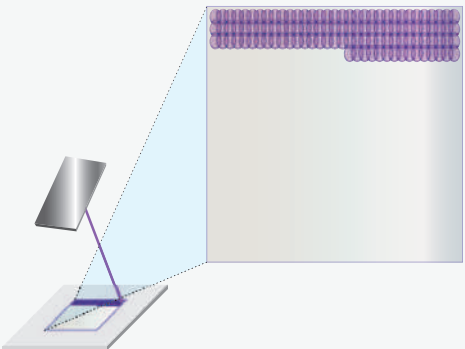

• **High X-Y Plane Resolution**

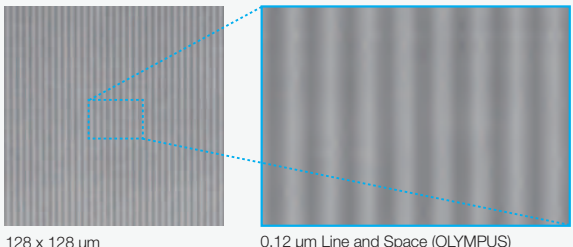

128 x 128 μm 0.12 μm Line and Space (OLYMPUS)

LSM Solution for	
Interferometer Samples	LSMs have superior horizontal resolution due to a confocal optical system, making it easy to measure the surface of the specific region of interest.

Superior Z-Axis Measurement

Accurate Measurement of Submicron Heights Across the Z-Axis

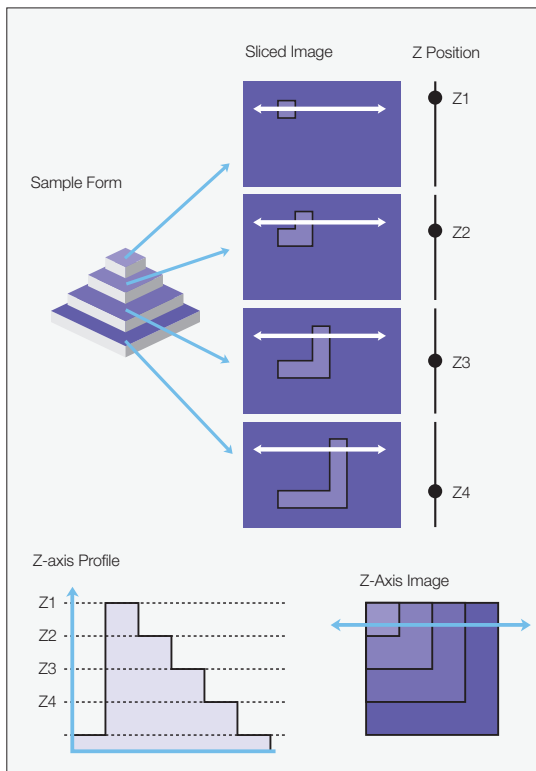

An SEM delivers excellent high-resolution images but lacks any height information. With a short-wavelength laser and its confocal optical system, an LSM only detects in-focus reflections from a single specified focal plane along the Z-axis. Combined with a high-precision linear scale, this allows high-definition imaging and accurate 3D measurement. The OLS4100 can achieve a Z-axis resolution of 10 nanometers.

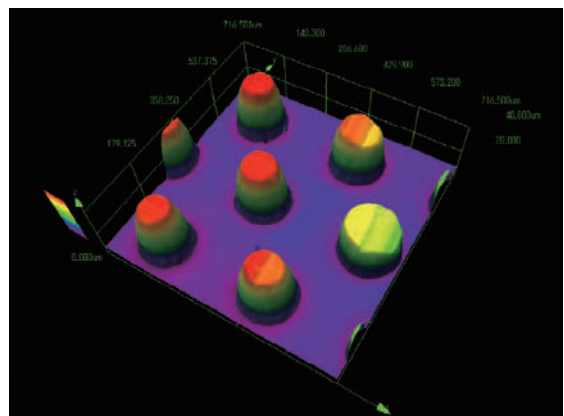

LSM Solution for		
SEM Samples	Interferometer Samples	LSMs are ideal for measuring the surface contour of samples with undulations ranging from several hundred micro-meters to the submicron order.

Superior Metrology

3D measurement of diverse samples with 10 nm height resolution and advanced measurement parameters.



Wider Sample Range

Imaging Slopes up to 85°

Thanks to dedicated objectives with high numerical apertures and a dedicated optical system that obtains superior performance from a 405 nm laser, the LEXT OLS4100 can reliably measure acute-angled samples that were previously impossible to measure. These capabilities also enable measurement of micro-roughness on an uneven surface.

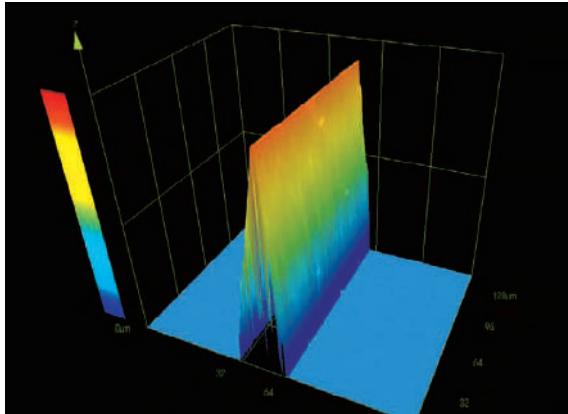

Razor with an Acute Angle



LEXT-Dedicated Objectives

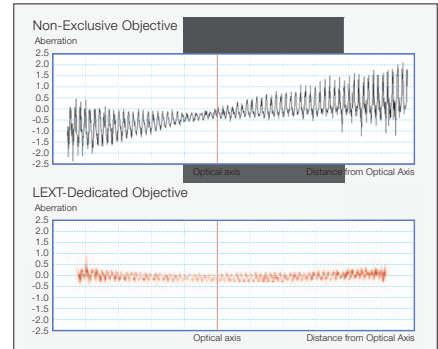

Minimized Aberrations with Dedicated Objective

Micro-Profile Measurements with 10 nm Height Resolution

With the OLS4100, an impressive X-Y resolution of 0.12 microns is now possible thanks to a short-wavelength 405 nm laser and a high-aperture objective. As a result, the OLS4100 can perform submicron measurements of a sample's surface. With a precise 0.8 nanometer-resolution linear scale and software algorithms such as our original I-Z curve (see page 23), the OLS4100 can resolve height differences of 10 nanometers.

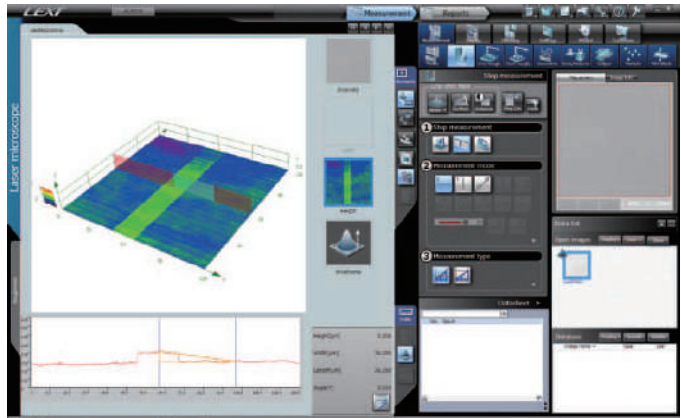

(MPLAPON50XLEXT)
STEP Height standard Type B, PTB-5, Institut für Mikroelektronik, Germany,
6 nm Detection in Height Measurement

Overcoming Reflectance Differences

The OLS4100 employs a dual confocal system, incorporating two confocal optical light paths. In combination with a high-sensitivity detector, this enables the OLS4100 to capture a precise 3D image from a sample consisting of materials with different reflectance characteristics.

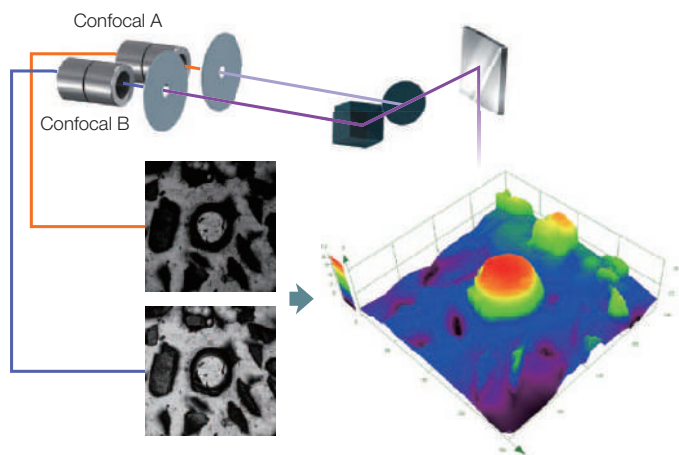

Diamond Electroplated Tool
Objective : MPLAPON50XLEXT

Applicable to Transparent Layers

Multilayer Mode

The LEXT OLS4100's new multilayer mode is capable of recognizing the peaks of reflected light intensities originating from multiple layers. Setting each layer as the focal point makes it possible to observe and measure the upper surface of a transparent sample. This also enables the analysis of multiple layers, measuring the thickness of each layer.

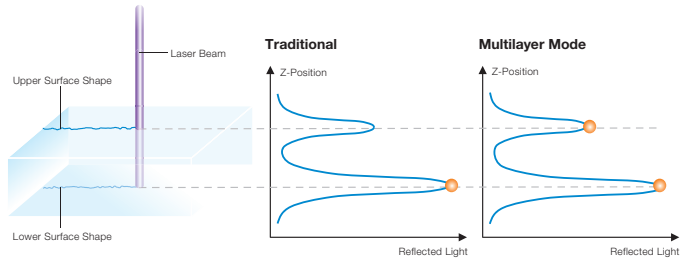

Observation/Measurement of Multiple Layers of Transparent Material

The multilayer mode facilitates observation and measurement of the transparent layer on the surface of a transparent sample. Even with a transparent resin layer on a glass substrate, the shape and roughness of each layer, as well as the thickness of the surface film, can be measured.

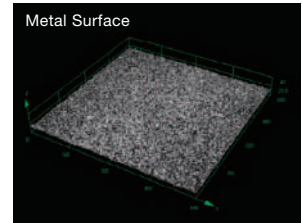
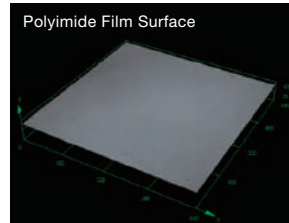
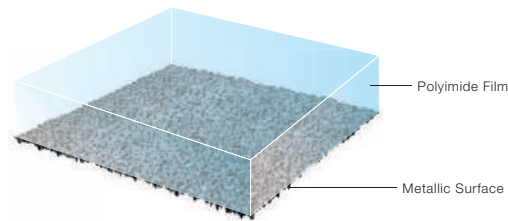

Industry's First* Double Performance Guarantee

Accuracy and Repeatability

The performance of a measuring tool is typically expressed using two different terms: "accuracy," which indicates how close a measurement value is to its true value, and "repeatability," which indicates the degree of variations among repeated measurement values. The OLS4100 is the industry's first* LSM able to assure both accuracy and repeatability.

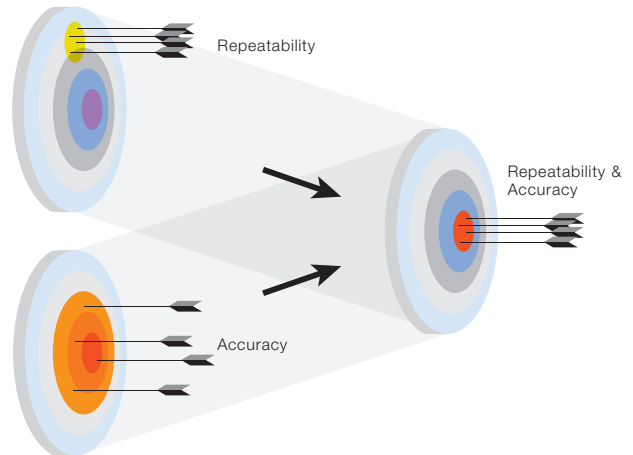

Traceability System

The OLS4100 uses a rigorous system of production for every component. From the objective to the laser head, Olympus delivers only the highest-quality systems based on comprehensive inspection to the strictest standards. On delivery, final adjustment and calibration is performed by qualified engineers in the actual measurement environment.

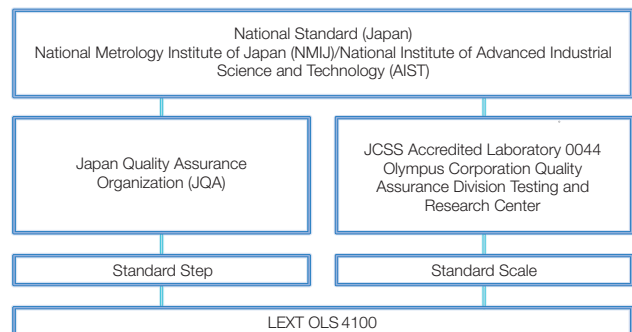

*According to Olympus survey as of Dec 2008.

Wide Range of Measurement Types

Seven Measurement Modes

Step Measurement

This mode allows measurement of a step between any two arbitrary points on a surface profile. Profile Measurement is also available.

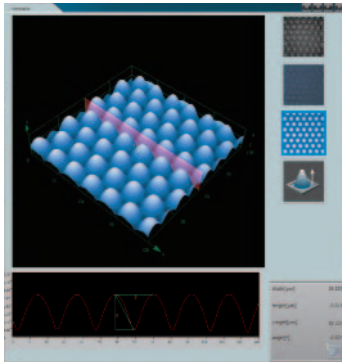

Surface Roughness Measurement

This mode allows measurement of line roughness on one line and plane roughness on the entire surface.

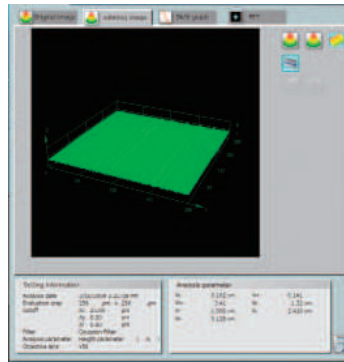

Area/Volume Measurement

With a user-defined threshold level on a surface profile, this mode allows measurement of the volume (or area) of a geometry above or below the threshold level.

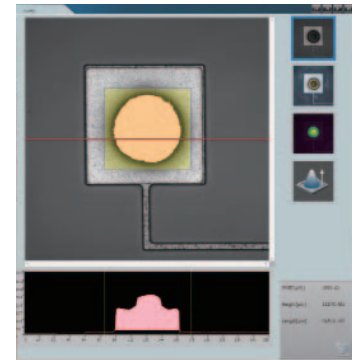

Particle Measurement*

This mode enables auto-separation of particles with the separator function, setting of a threshold level, and setting of a detection range within a region of interest.

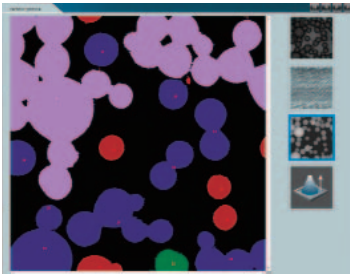

Particle	Area	Perim	CentX	CentY	MinX	MinY	MaxX	MaxY	Volume
1	123.45	12.34	10.2	15.6	5.1	1.2	15.3	20.1	1.23
2	456.78	23.45	25.3	30.4	10.2	2.1	30.4	40.5	4.56
3	789.01	34.56	40.4	45.5	15.3	3.2	45.6	55.6	7.89
4	234.56	18.90	15.6	20.7	8.9	1.3	20.8	25.9	2.34
5	567.89	27.01	20.7	25.8	11.0	2.4	25.9	31.0	5.67

Geometric Measurement

This mode allows measurement of the distance between two arbitrary points on a geometric image. The geometric shape and angle for circle, rectangle, etc. are measured.

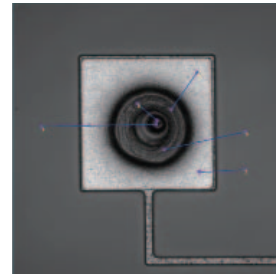

Measurement	Value
Distance	12.34
Area	45.67
Perim	23.45
CentX	10.2
CentY	15.6

Film Thickness Measurement*

This mode allows the thickness of a film on a transparent body to be measured by detecting changes in refractive index.

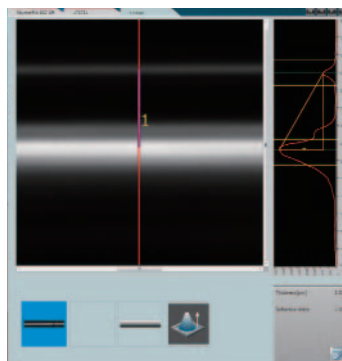

Auto Edge Detection/Measurement*

This mode allows a line width or a diameter to be measured by automatically detecting edges in a geometric image. This reduces uncertainty by eliminating operator error.

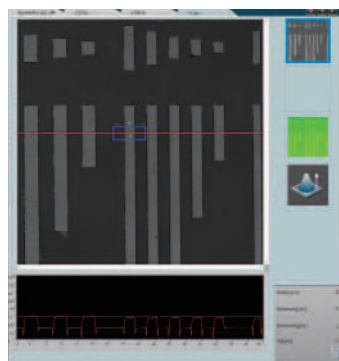

OLYMPUS Stream*

Workflow Solution for Improved Image Analysis Performance

For grain size analysis or nonmetallic inclusion rating, optional OLYMPUS Stream micro-imaging software is available, which can be uploaded directly from the OLS4100.



OLYMPUS Stream
Launch Button

*Optional unit.

Improved Roughness Measurement

The LEXT OLS4100 has been developed to represent a new standard of surface roughness measuring. The OLS4100 is calibrated in the same way as contact surface roughness gauges and has the necessary roughness parameters and filters required per ISO and JQA. This allows users with contact surface roughness gauges to obtain output results from the system consistent with their existing instruments, with the advantage of greater speed and non-contact measurement. The OLS4100 has a roughness-specific mode enabling roughness profile measurement for sample lengths up to 100mm with an automatic line stitching function.

Micro Roughness

Contact surface roughness gauges cannot measure micro surface contours less than the stylus tip diameter. The OLS4100 can measure the surface roughness of micro geometries at high resolution due to a minute laser spot diameter.

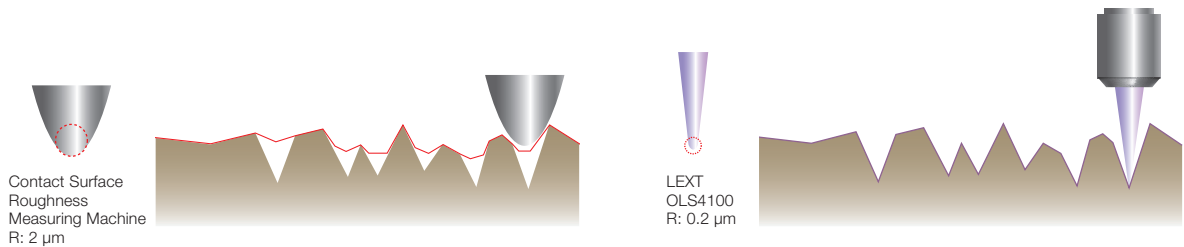

Non-Contact Measurement

Since a contact surface roughness gauge uses a hard needle-shaped stylus, it is more likely to scratch the surface of a soft specimen, damaging or deforming it. With adhesive specimens, on the other hand, the stylus can attach to the specimen and be damaged when pulled loose, making it impossible to obtain correct results. The OLS4100, a non-contact laser microscope, can perform accurate surface roughness measurement regardless of surface texture conditions.

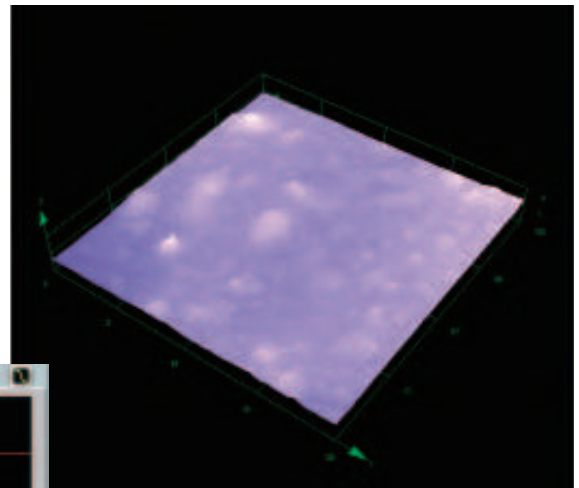

Polymer Film 3D image (above) and Results of Roughness Measurement (left)

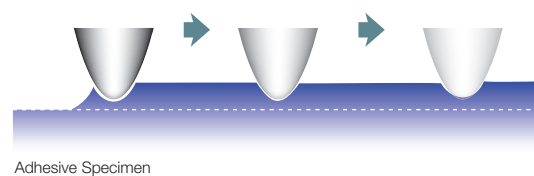
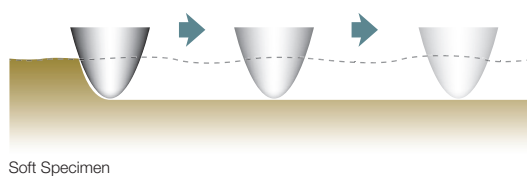
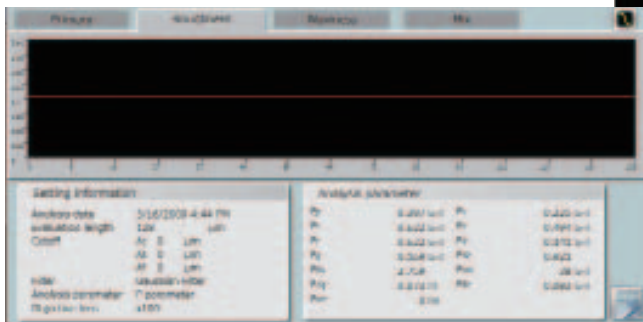

Measurement of Features at the Micron Level

Surface roughness gauges cannot measure micron-level features since their styli are not able to access these areas. The OLS4100 can correctly identify a measuring position and easily perform roughness measurement of a target micro area.

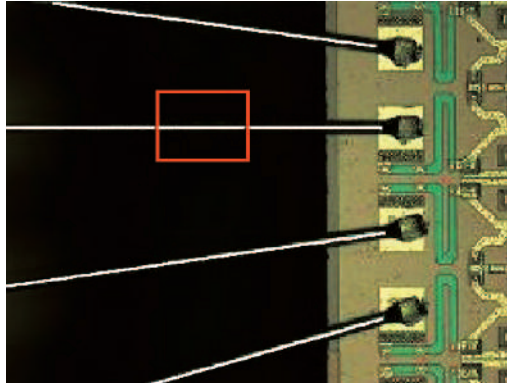

Bonding Wires

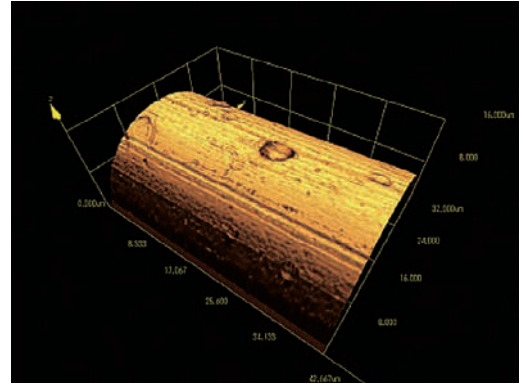

LEXT OLS4100 Parameters

Parameter Compatibility

The OLS4100 comes with the same Surface Profile Parameters as contact-type surface roughness gauges, offering compatible operability and measurement results.

Primary Profile	: <i>Pp, Pv, Pz, Pc, Pt, Pa, Pq, Psk, Pku, Psm, PAq, Pmr(c), Pôc, Pmr</i>
Roughness Profile	: <i>Rp, Rv, Rz, Rc, Rt, Ra, Rq, Rsk, Rku, Rsm, RAq, Rmr(c), Rôc, Rmr, RZJIS, Ra75</i>
Waviness Profile	: <i>Wp, Wv, Wz, Wc, Wt, Wa, Wq, Wsk, Wku, Wsm, WΔq, Wmr(c), Wôc, Wmr</i>
Bearing Area Curve	: <i>Rk, Rpk, Rvk, Mr1, Mr2</i>
Motif	: <i>R, Rx, AR, W, Wx, AW, Wte</i>
Roughness Profile (JIS1994)	: <i>Ra(JIS1994), Ry, Rz(JIS1994), Sm, S, tp</i>
Others	: <i>R3z, P3z, PeakCount</i>

Accommodating Next-Generation Parameters

The OLS4100 comes with roughness (3D) parameters conforming to ISO25178 for reliable evaluation of the planar area.

Amplitude Parameters	: <i>Sq, Ssk, Sku, Sp, Sv, Sz, Sa</i>
Functional Parameters	: <i>Smr(c), Sdc(mr), Sk, Spk, Svk, SMr1, SMr2, Sxp</i>
Volumetric Parameters	: <i>Vv(p), Vvv, Vvc, Vm(p), Vmp, Vmc</i>
Lateral Parameters	: <i>Sal, Str</i>

- LEXT OLS4100 performance is comparable with results of a surface roughness gauge.

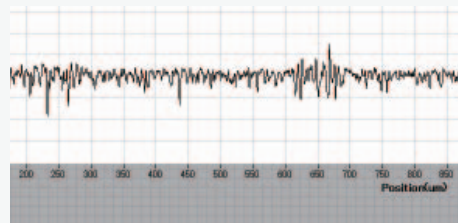

Primary Profile from LEXT OLS4100
λs=2.5 μm with Filtering

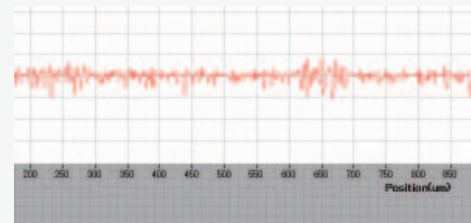

Primary Profile from a Contact Surface Roughness Gauge

High-Quality Imaging

For clear 3D color images, high-sensitivity laser DIC, or high-dynamic range (HDR) images.



Crystal-Clear 3D Color Images

Three Types of Integrated Images

The LEXT OLS4100 can acquire three different types of information at the same time: a true-color optical microscope image, a laser microscope image, and height map. The OLS4100 makes it possible to capture an optical microscope image consisting of in-focus pixels only, and integrate them with a true-color optical microscope image containing height information.

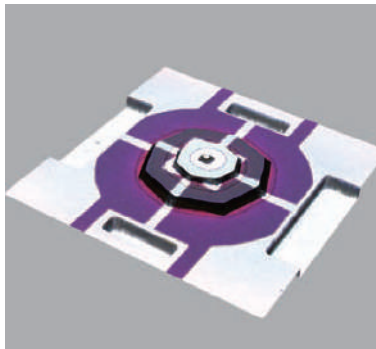

Real-Color 3D Image

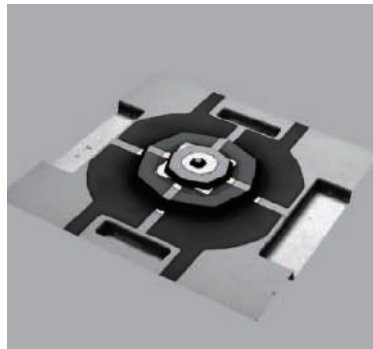

Confocal 3D Laser Image

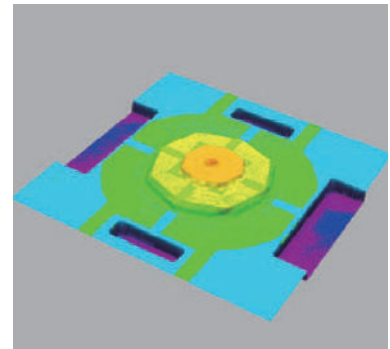

Height Map

Natural Color Reproduction

The OLS4100 uses a white LED light and a high-color-fidelity CCD camera to generate clear, natural-looking color images, comparable to those obtained with high-grade optical microscopes.

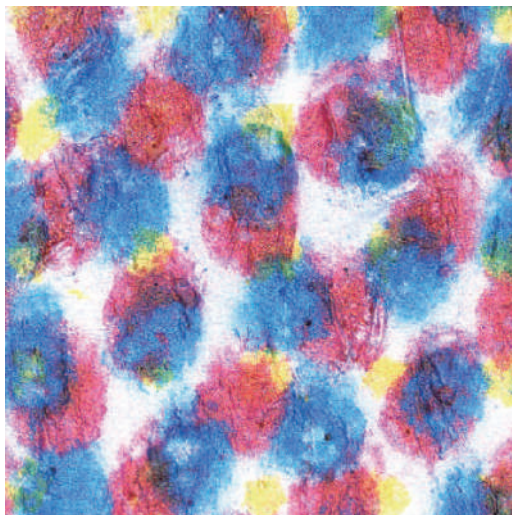

2D Color Image (Inkjet Dots on Paper, Objective 20x)

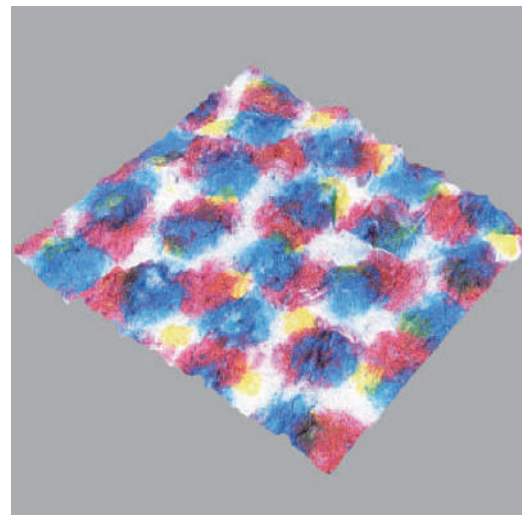

3D Color Image (Inkjet Dots on Paper, Objective 20x)

More Realistic Surface Reproduction

Laser DIC (Differential Interference Contrast)

DIC

Differential Interference Contrast (DIC) is an observation method used to visualize nanometer micro surface contours, which normally lie far beyond the resolving power of a laser microscope. Thanks to its DIC laser mode, the LEXT OLS4100 allows you to obtain live images comparable to those of an electron microscope, under relatively low power magnifications.

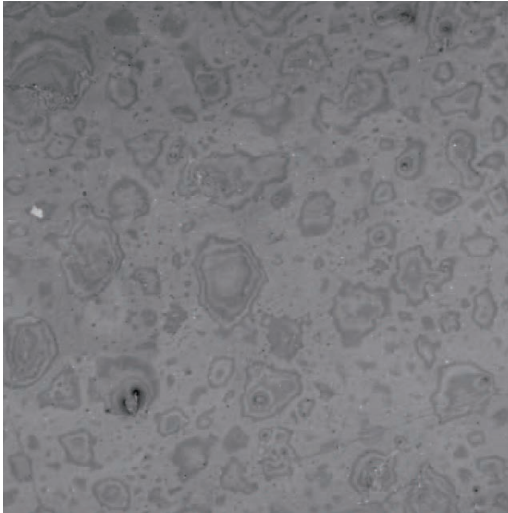

Laser Image without DIC (Polymer Film)

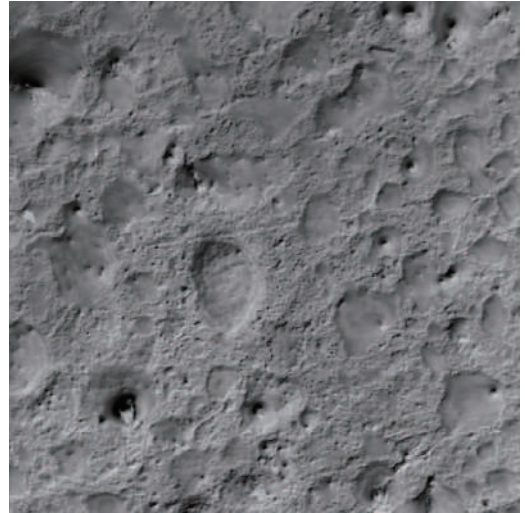

Laser Image with DIC (Polymer Film)



Laser Image without DIC (5x Objective)
STEP Height standard Type B, PTB-5, Institut für Mikroelektronik, Germany

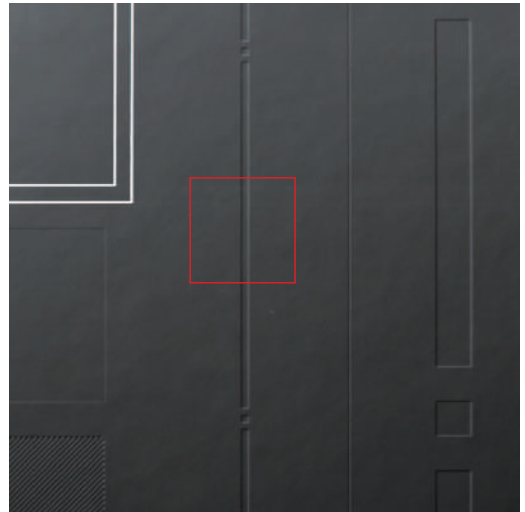

Laser Image with DIC (5x Objective)
STEP Height standard Type B, PTB-5, Institut für Mikroelektronik, Germany,
Actual Height of the Feature : 6 nm

Optimized Balance Between Brightness and Contrast

HDR

HDR (High Dynamic Range) Imaging

The OLS4100's High Dynamic Range (HDR) function combines several optical microscope images captured using different exposures. Brightness, contrast, texture, and saturation are controlled individually so that HDR creates images with a wide dynamic range. This enables clear visualization of a color image, especially for samples lacking texture.

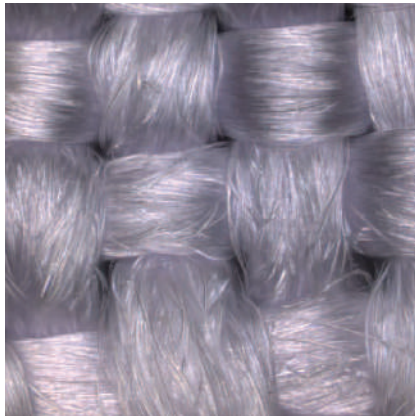

Color Image without HDR
(Super-Density Fabric, Objective 20x, Zoom 1x)



Color Image with HDR
(Super-Density Fabric, Objective 20x, Zoom 1x)

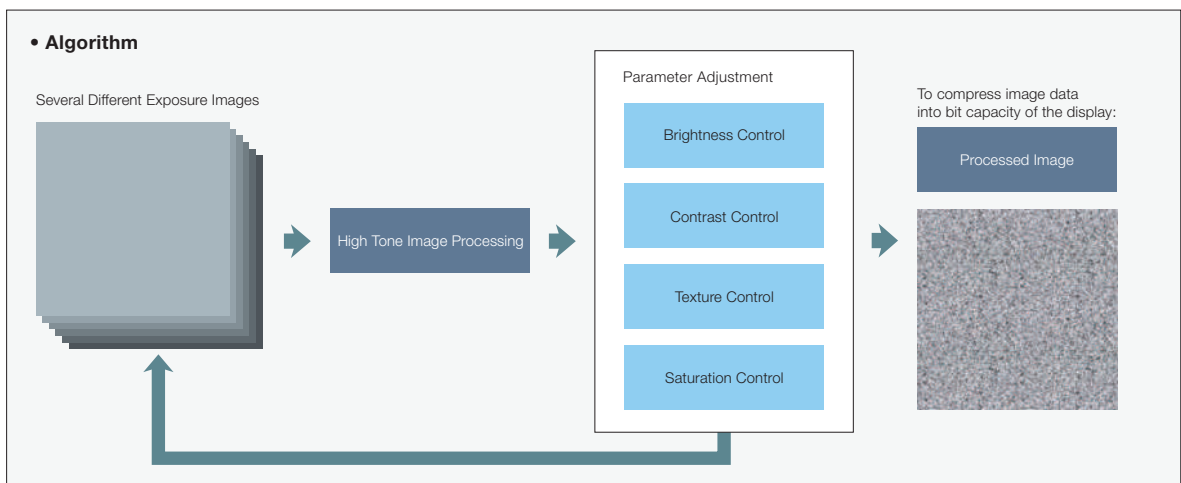

Stabilization of Measurement and Imaging Environments

To eliminate external influences on measurement and imaging, the OLS4100 incorporates a hybrid vibration-dampening mechanism using coil springs and dampening rubber to stabilize the operating environment. This eliminates the need for a dedicated vibration-dampening stand, allowing measurements on any desktop.

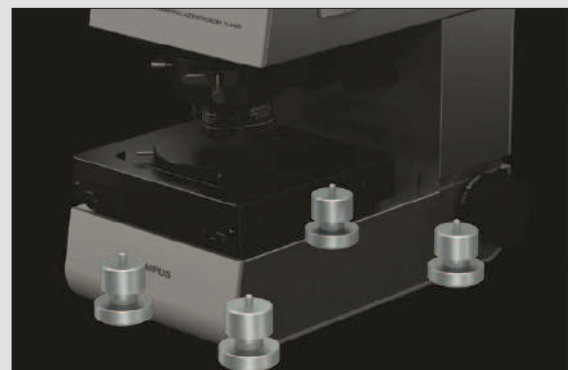

Hybrid Vibration-Dampening Mechanism

Systematic Workflow via Intuitive GUI

Easy operation accomplishes your goals faster than ever.

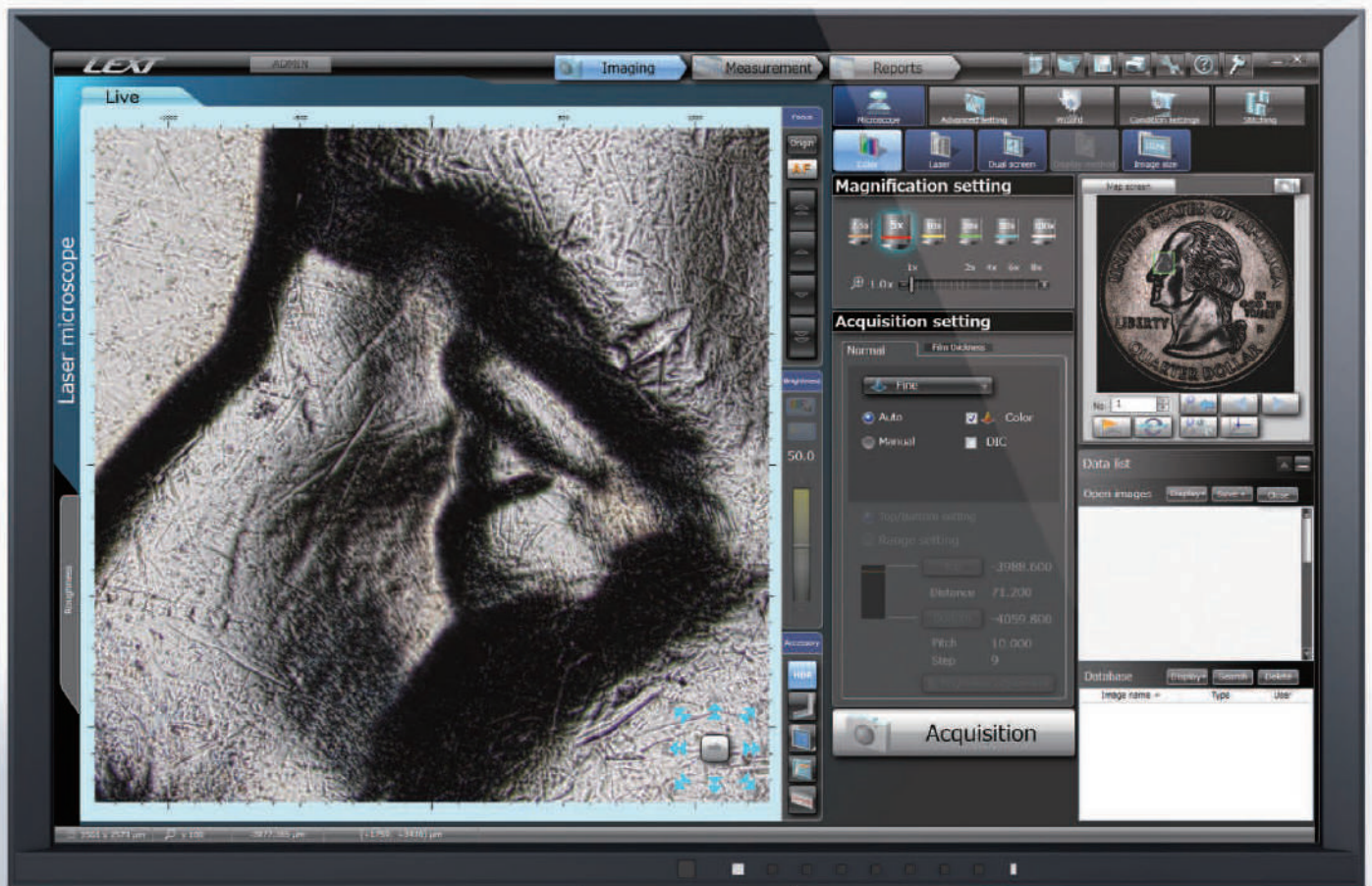

Easy Three-Step Process

With the LEXT OLS4100, observation or measurement begins immediately once the sample is placed on the stage. Thanks to our easy three-step “Imaging, Measurement and Reports” process, measurement procedures can be quickly mastered, even by those not familiar with laser microscopy.

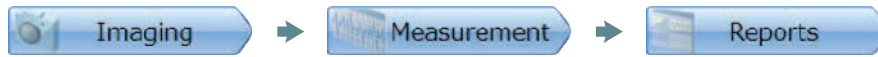

Keeping Track of the Sample

Macro Map Functionality

The OLS4100's macro map function allows wide-field image display of a sample under low magnification, with a rectangular observation marker on the macro sample image. The field of view can be set up to 441 (21x21) times wider than the conventional view. When used with the motorized six-lens nosepiece, the macro map function allows smooth, convenient, one-click operation for stage movement and magnification. Accurate parfocality and objective centering can be preset and synchronized with one-click stage movement and magnification.

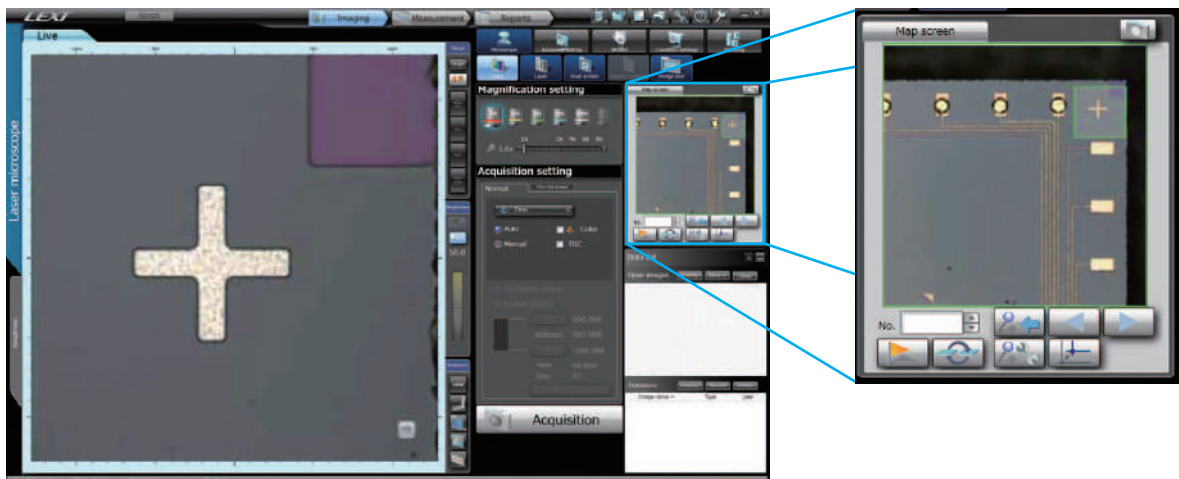

Fast Macro Map Stitching

Two stitching methods are available for scanning large areas: Manual mode for live image acquisition and Automatic mode for faster image acquisition. Operation is quick and simple—2D stitching starts automatically at the touch of a single button, and wide area images are acquired immediately. The stitching size is available from five steps in 3x3, 5x5, 7x7, 9x9, and 21x21 in Automatic mode. Unnecessary parts of the acquired images can also be removed manually with simple mouse/joystick operation.



Smart Scan for Simple 3D Imaging

Speed of image acquisition is significantly increased, with automatic adjustments for brightness and position across the Z-axis direction and planar surface.

Automatic 3D Image Acquisition

Conventional 3D scanning requires complicated settings that are difficult for novice users. With the LEXT OLS4100's new Smart Scan mode, even first-time users can quickly acquire 3D images with a single click of a button. In addition to upper and lower limit settings, appropriate brightness level is automatically set up by the system based on the image to be captured, allowing even new users to obtain accurate height measurements and an optimized image.

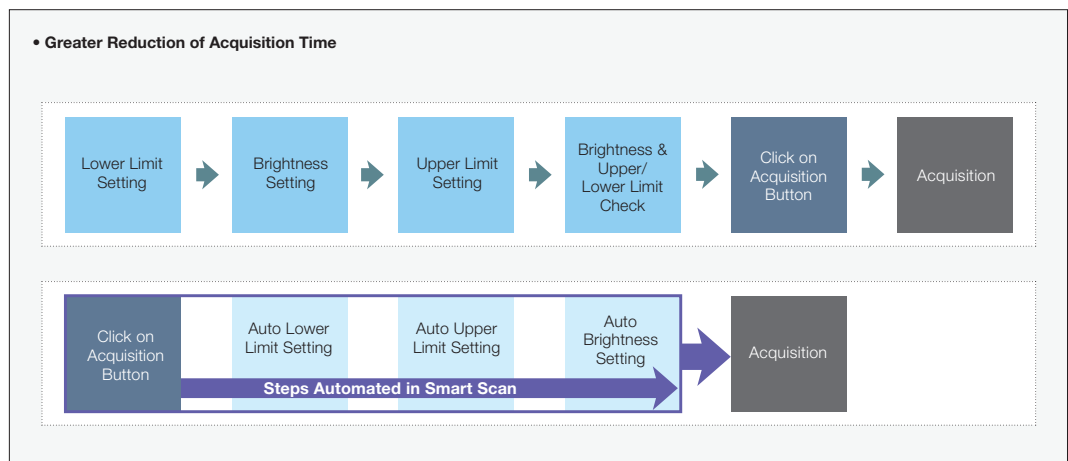
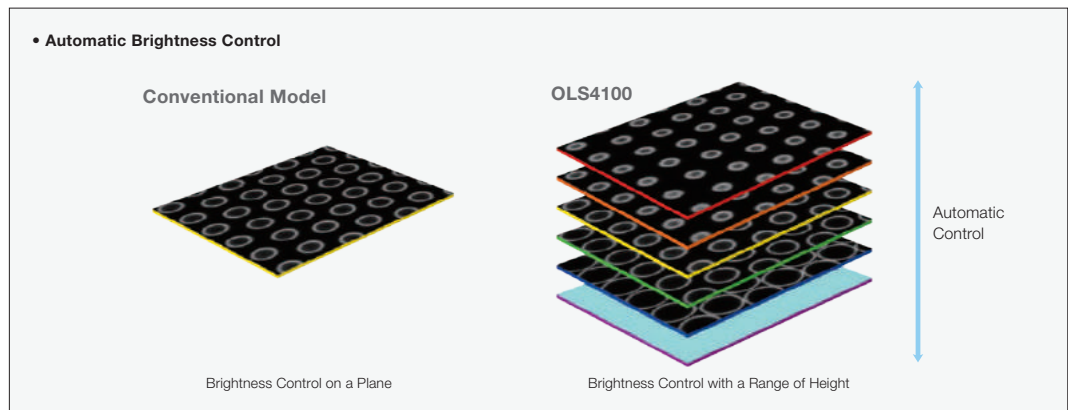
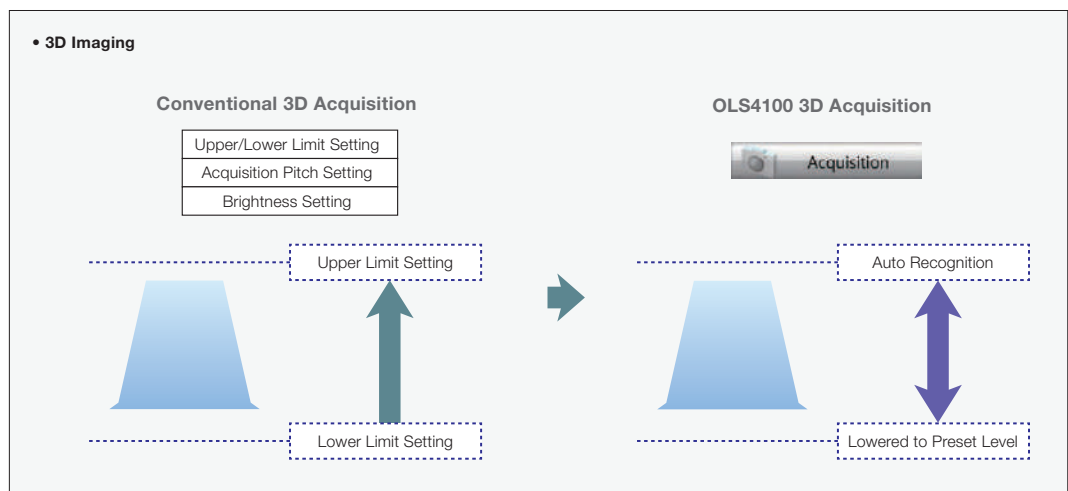

Improved Scanning Speed

The new Ultra-Fast mode allows scanned image acquisition at twice the speed of conventional Fast mode, and approximately nine times the speed of Fine mode. This makes it possible to measure micro-samples with very steep angles, such as the tip of a knife, which is difficult to observe due to fine Z-step movement and high magnification.

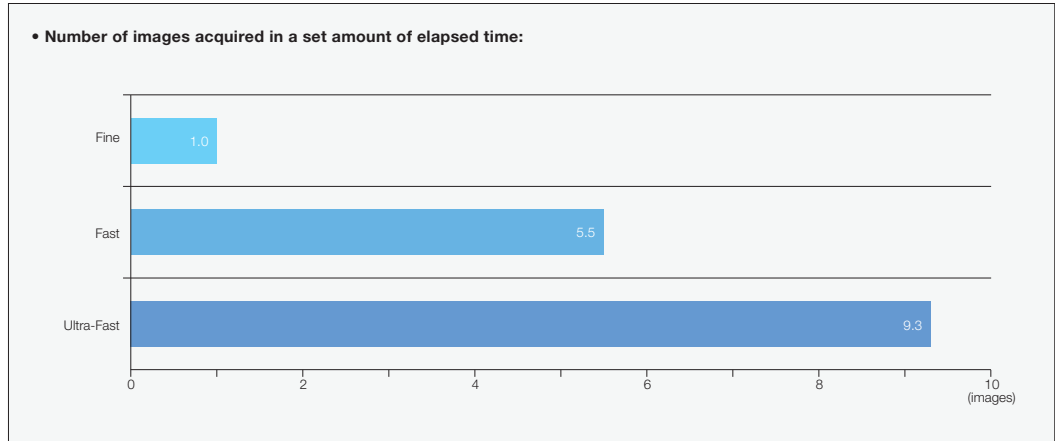

Actual scanning time varies depending on magnification and Z-acquisition range.

High-Speed Acquisition of Required Areas Only

The OLS4100 also comes with a Band Scan mode for measurement of limited target areas, providing measurement performance 1/8th faster than conventional modes.

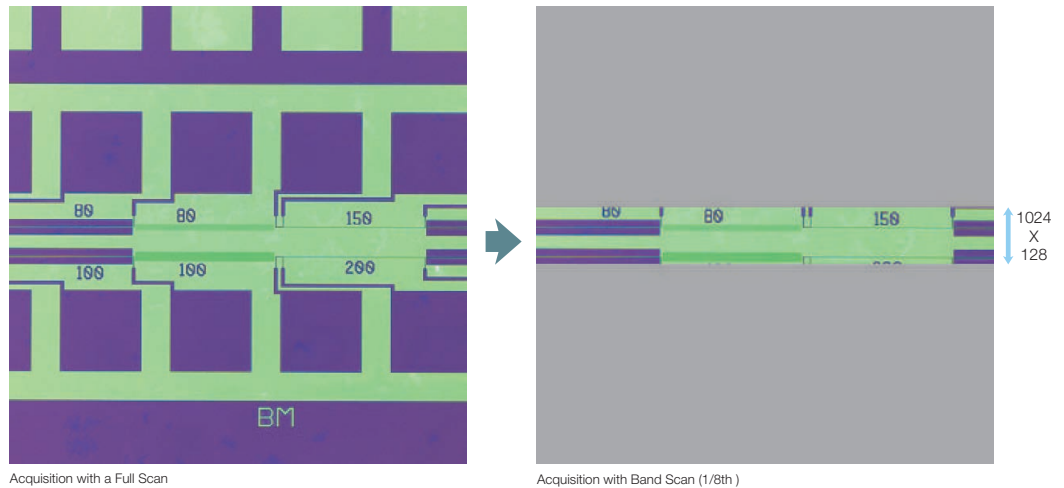

Acquisition with a Full Scan

Acquisition with Band Scan (1/8th)

New High-Speed Stitching Mode

Specify Target Areas from Wider-Area Stitched Images

As in macro mapping, the area to be observed can be specified from a wide area map. In Automatic mode, an area map can be automatically generated in roughly half the time it normally takes by setting a rectangular stitching size of up to 625 images. Observation can begin immediately once the target area is specified on the area map.

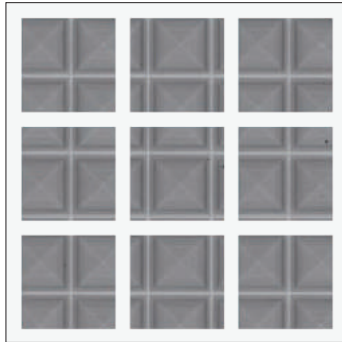

Individual 2D Images Before Stitching (Simulation)

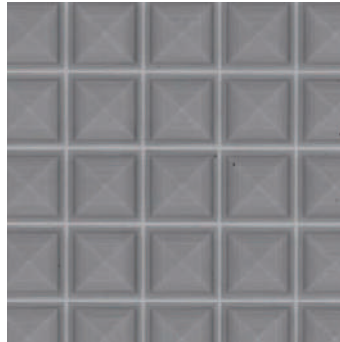

2D Image After Stitching

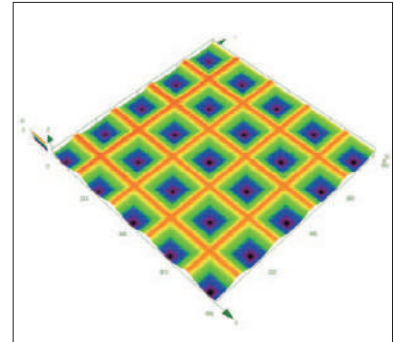

3D Image After Stitching



Stitching Area: Square (21x3) 63 Pieces

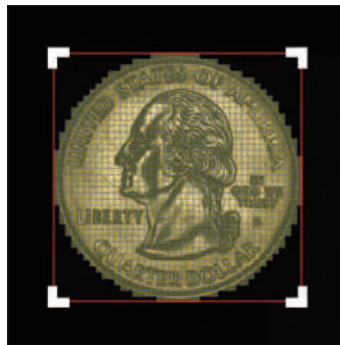

Stitching Area: Circle (3 Points)

Manually Specifying Required Image Areas

In Live mode, the area to be observed can be selected manually by tracing the required region onscreen. This is ideal when the sample has an irregular shape.

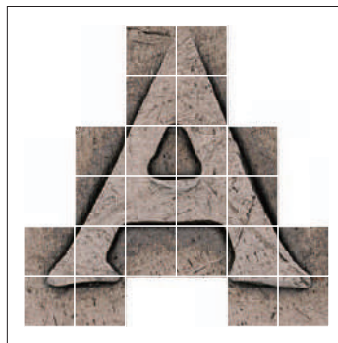

Quick Image Acquisition

In Smart Scan mode, all it takes is the click of a button. As the location across the Z-axis is automatically adjusted, image acquisition in the Z-axis direction can be restricted to required areas only, for rapid high-power observation across a wide area.

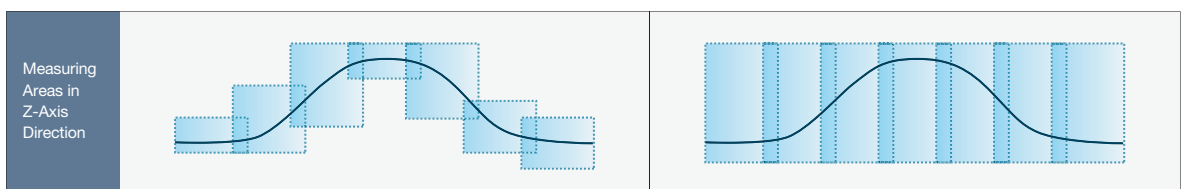

Smart Scan Mode

Conventional Acquisition Mode

Customizable Reports at the Touch of a Button

Report Creation

The OLS4100 generates reports at the touch of a button after measurement, and an edit function allows the operator to customize each report template. Copying and pasting measured results into a word processing/spreadsheet application is also quite simple, as is retrieving required images/reports from a database.

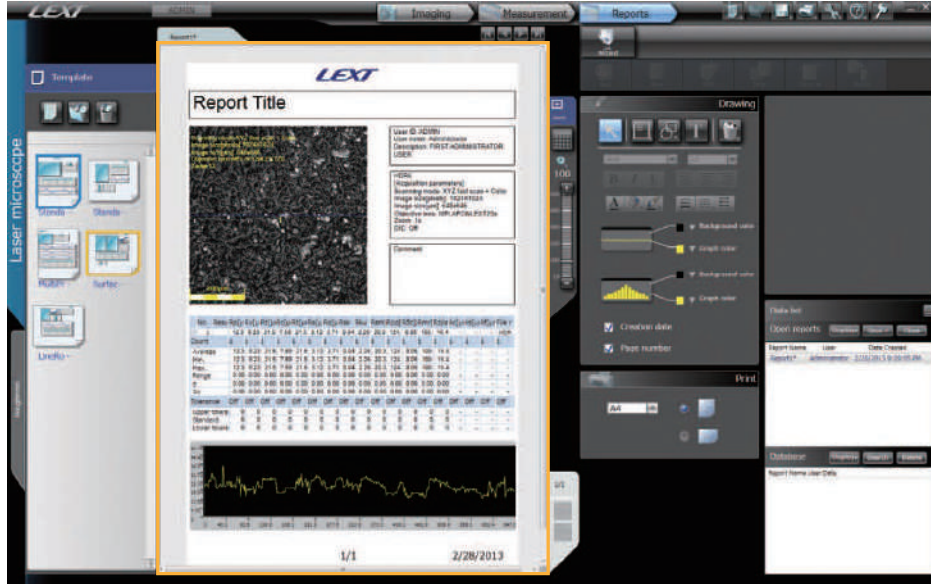

One-Click Solutions

Wizard Function

A detailed user-designed wizard function eliminates the need for lengthy training and allows quick and easy operation by new operators.

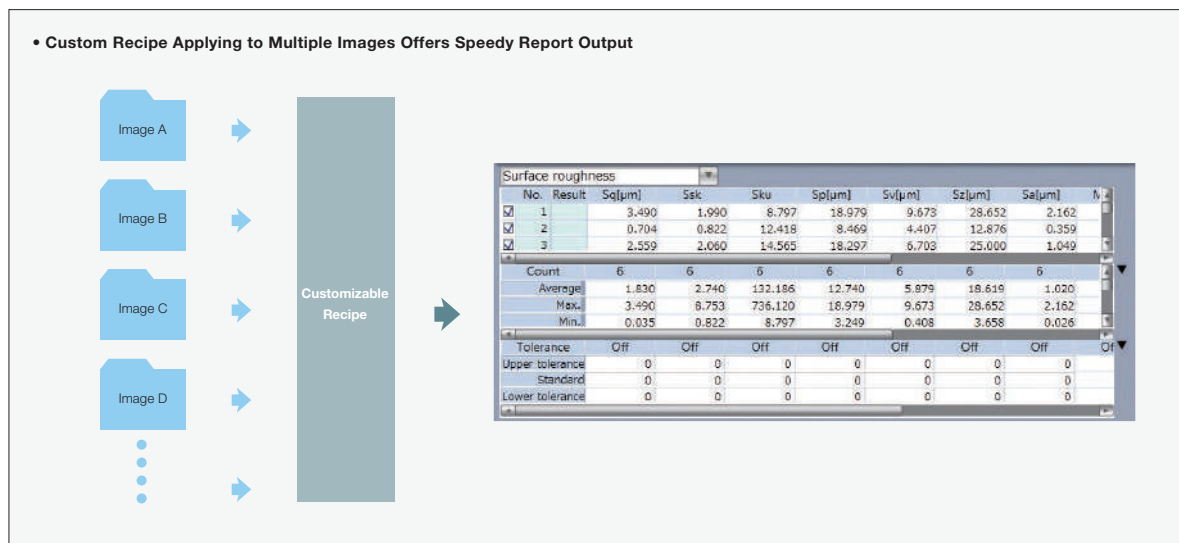

Basic Principles of the LEXT OLS4100

405 nm Laser Scan

The lateral resolution of an optical microscope is defined largely by the parameters of the optics and the wavelength of the light source. With a 405 nm short-wavelength semiconductor laser, the LEXT OLS4100 enjoys a high lateral resolution in comparison to a conventional microscope using visible light with a 550 nm peak.

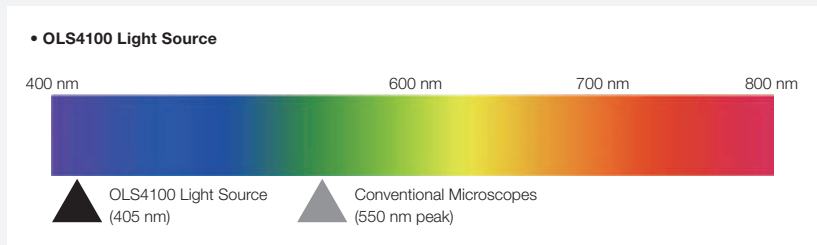

2D Scanning System

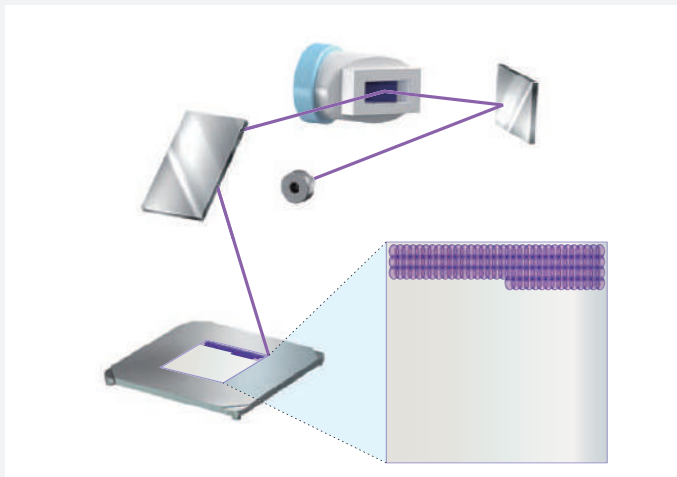

For 2D scanning, the OLS4100 incorporates an Olympus scanner-on-scanner. An electromagnetic MEMS scanner handles the X direction, while a high-precision Galvano mirror takes care of scanning in the Y direction. This innovative system enables the axis of the scanner and the exit pupil of the objective to be placed at an optically conjugate position. This ideal optical layout allows accurate high-speed, low-distortion X-Y scanning, enabling the OLS4100 to provide high-density scanning up to 4096 x 4096 pixels.

Confocal Optical System

A confocal optical system captures only the in-focus image while simultaneously eliminating flare. In addition, confocal technology can be used as a height sensor since only thin image planes of the same height are captured. The OLS4100 is equipped with an Olympus dual confocal system, enhancing optical performance for precise 3D images even with samples made up of materials with different reflectances. The circular pinhole point of laser light also produces a uniform confocal effect, enhancing contrast in every direction.

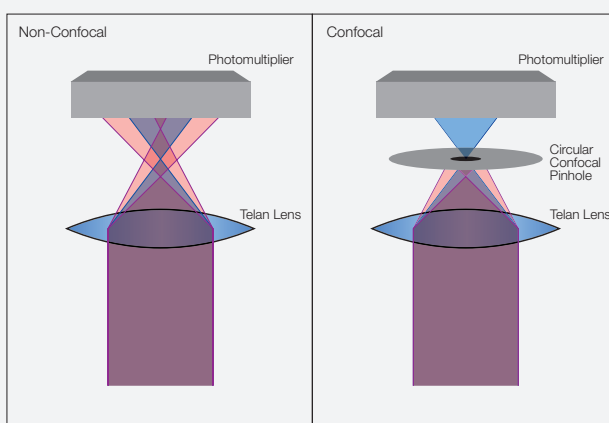

CFO Search

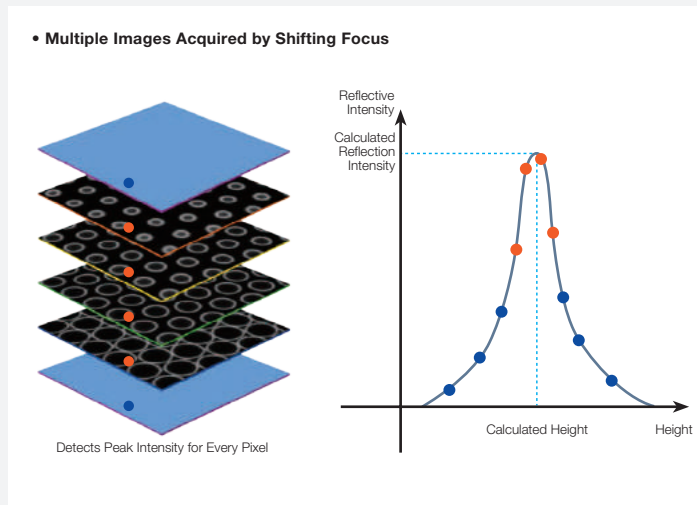

Obtaining height information is a primary function of the OLS4100 and is achieved by moving the objective upward to detect the change of light intensity along the Z-axis. Olympus CFO (calculated focus operation) technology detects light intensity automatically in order to obtain discrete height data. The approximate curve of an ideal I-Z curve is calculated alongside the maximum brightness value and Z-axis information, which define each image pixel. CFO search technology significantly improves repeatability—one of the most indispensable assets of a measurement tool.

OLS4100 Optical Path Diagram

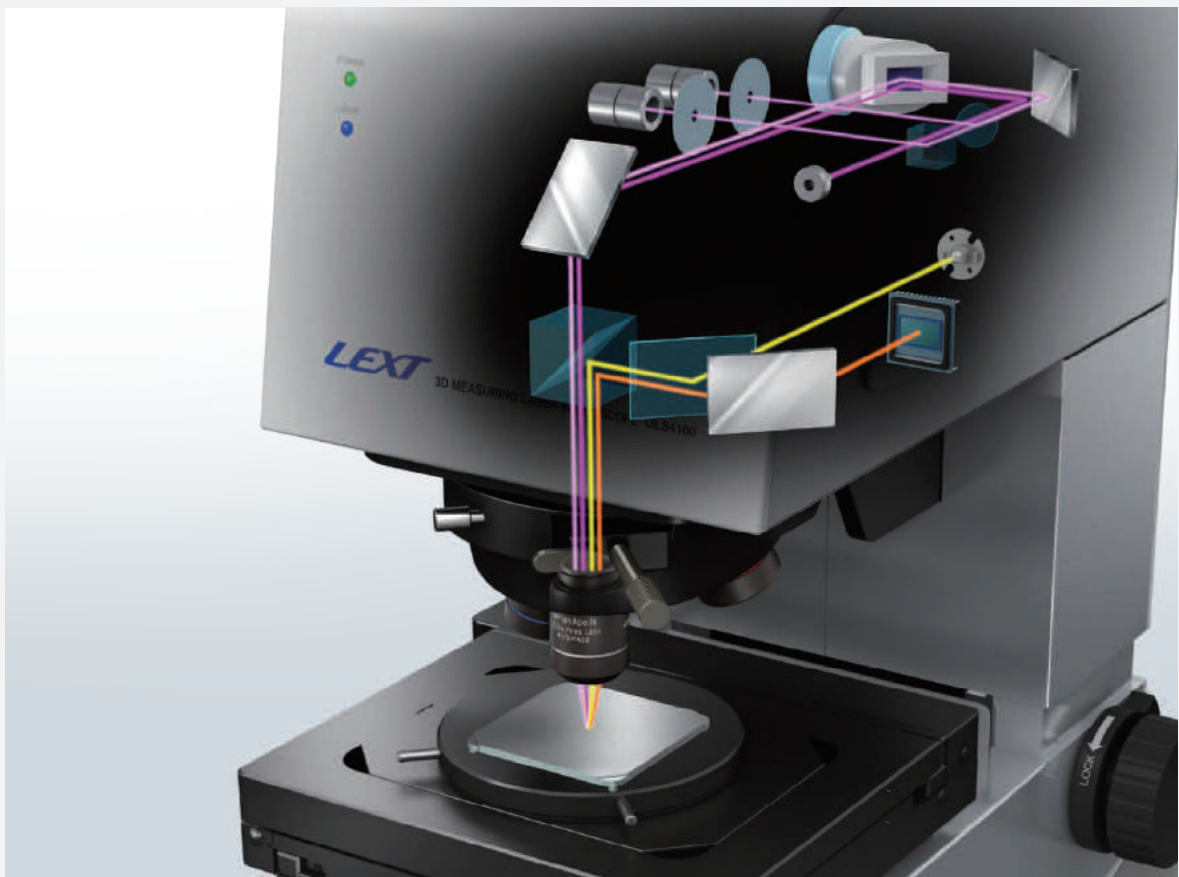

Based on these basic principles, the LEXT OLS4100 offers the following features:

10-nanometer resolution in the Z-axis direction to enable 3D surface contour measurement

Horizontal (X-Y direction) resolution of $0.12 \mu\text{m}$ to enable high-definition image observation

Violet laser enables non-contact observation and measurement

Sample Applications

Semiconductor/FPD (Flat Panel Display)

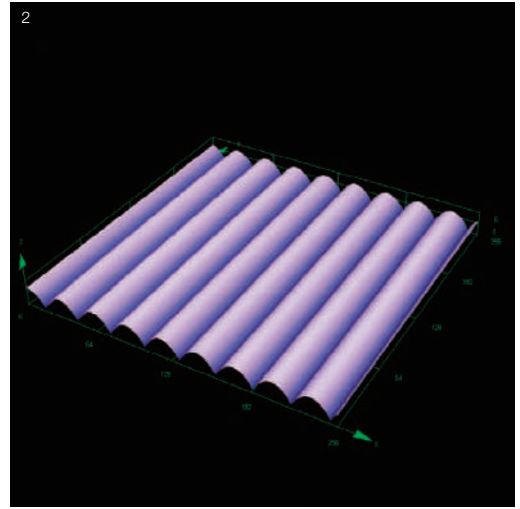
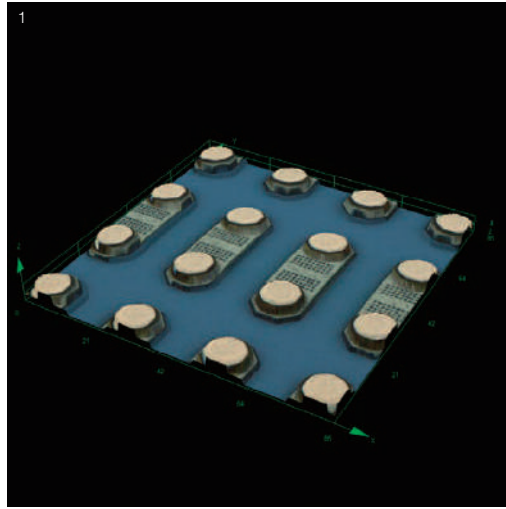

- 1 Wafer Bump**
(objective 100x/optical zoom 1.5x/scanning area 85 μm x 85 μm)
- 2 Light Guide Panel**
(objective 50x/optical zoom 1x/scanning area 256 μm x 256 μm)
- 3 Chip Pad**
(objective 50x/optical zoom 2x/scanning area 128 μm x 128 μm)
- 4 Laser Dot on Light Guide Panel**
(objective 100x/optical zoom 1x/scanning area 128 μm x 128 μm)

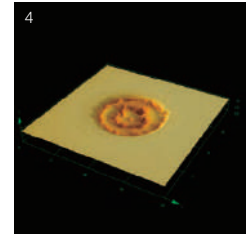
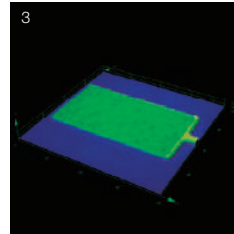

Electronic Component/MEMS (Microelectromechanical System)

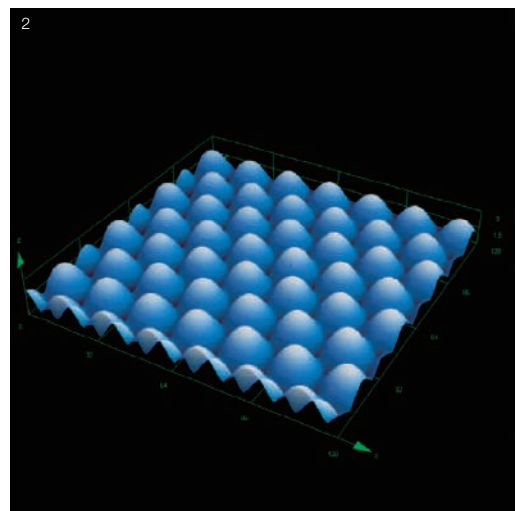
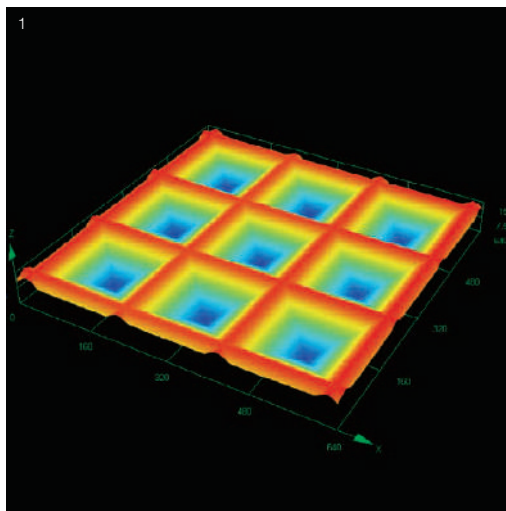

- 1 Photomask**
(objective 20x/optical zoom 1x/scanning area 640 μm x 640 μm)
Sample provided by Koshibu Precision Co., Ltd. (P3,P24)
- 2 Micro Lens**
(objective 100x/optical zoom 1x/scanning area 128 μm x 128 μm)
- 3 Flexible PCB Connector**
(objective 50x/optical zoom 1x/scanning area 256 μm x 256 μm)
- 4 MEMS**
(objective 20x/optical zoom 1.3x/scanning area 483 μm x 483 μm)

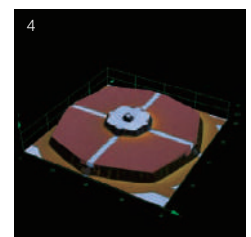
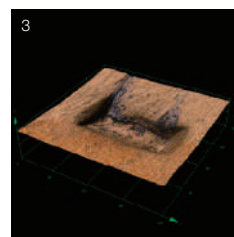

Material/Metal Processing

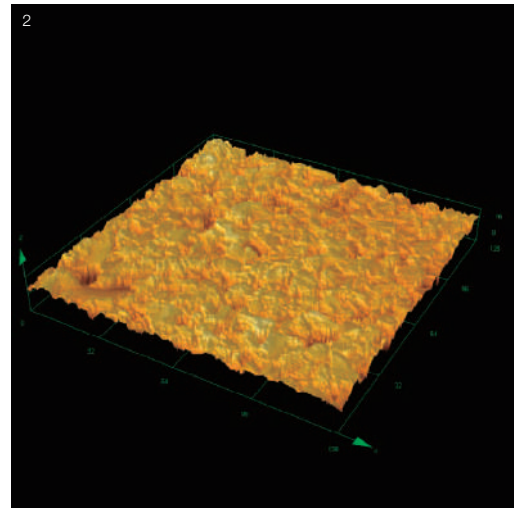
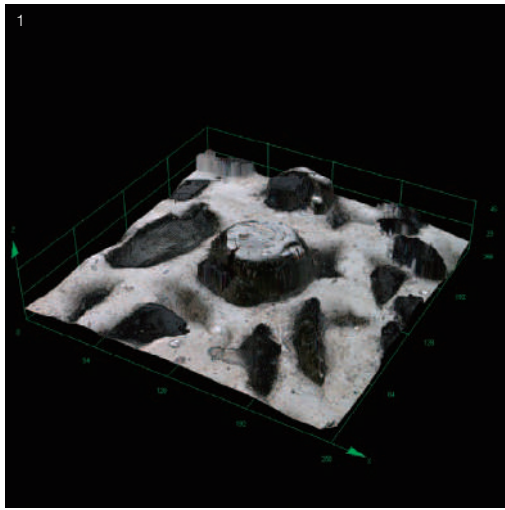

- 1** Diamond Electrocoating Tool
(objective 50x/optical zoom 1x/scanning area 256 μm x 256 μm)
- 2** Carbon
(objective 100x/optical zoom 1x/scanning area 128 μm x 128 μm)
- 3** Ultra-Thin Pipe
(objective 100x/optical zoom 1x/scanning area 128 μm x 128 μm)
- 4** Adhesive Tape
(objective 50x/optical zoom 2x/scanning area 128 μm x 128 μm)

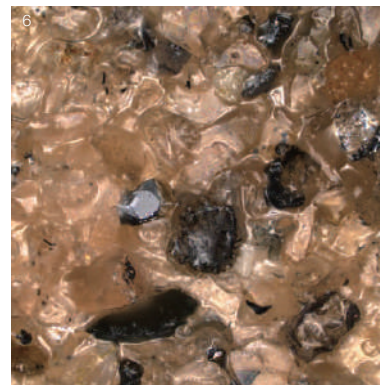
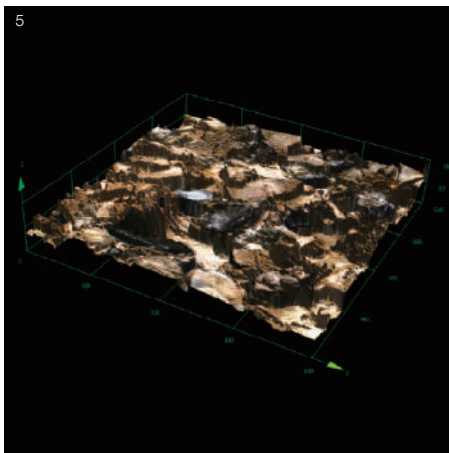
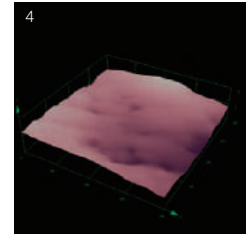
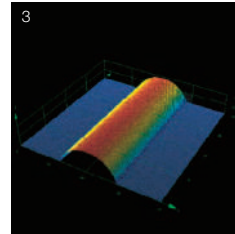

- 5** Sandpaper #400 (3D)
(objective 20x/optical zoom 1x/scanning area 640 μm x 640 μm)
- 6** Sandpaper #400 (2D)
(objective 20x/optical zoom 1x/scanning area 640 μm x 640 μm)
- 7** Super-Density Fabric (3D)
(objective 20x/optical zoom 1x/scanning area 640 μm x 640 μm)

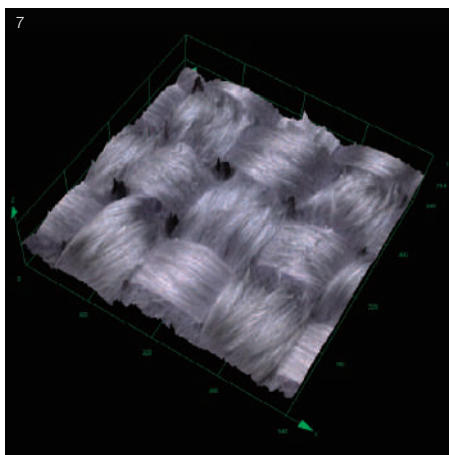

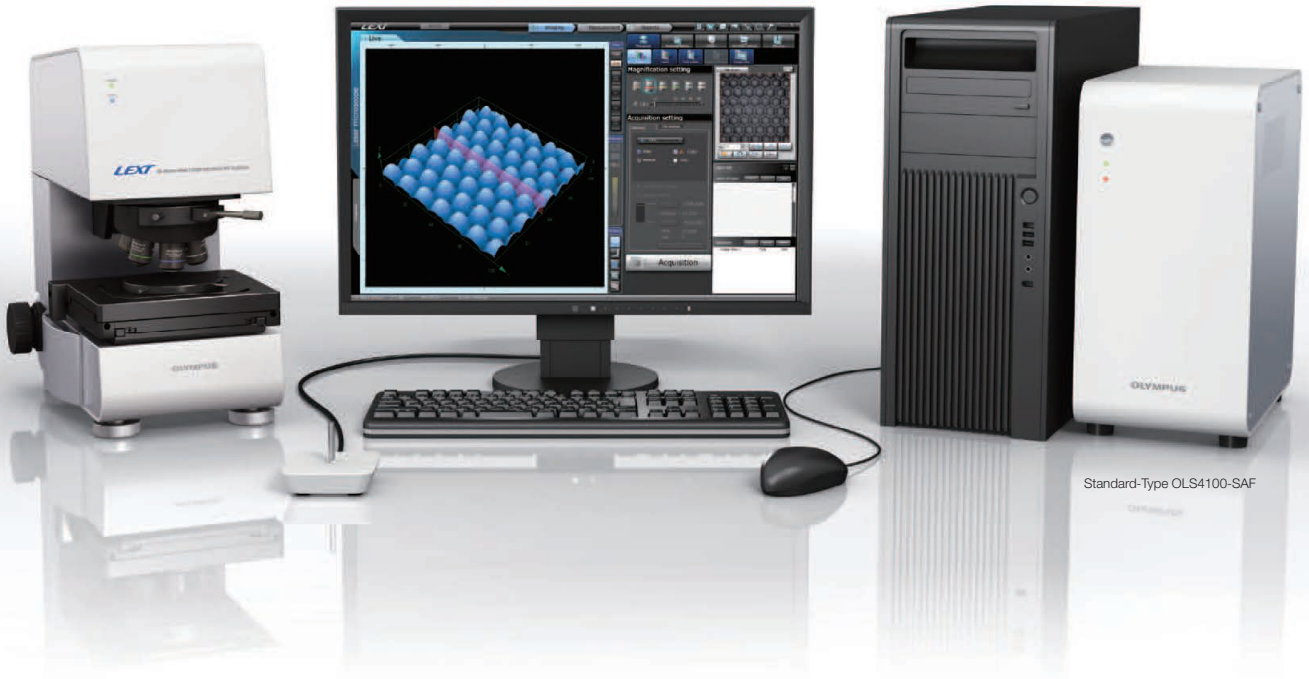

Standard-Type OLS4100-SAF



300mm-Stage-Type OLS4100-LAF

MAIN UNIT DIMENSIONS

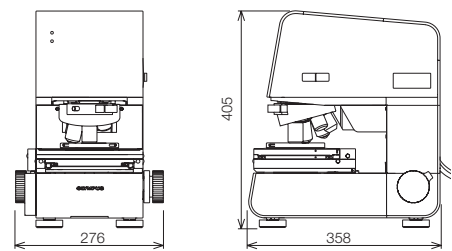

Unit: mm

COMBINATION SYSTEM DIMENSIONS

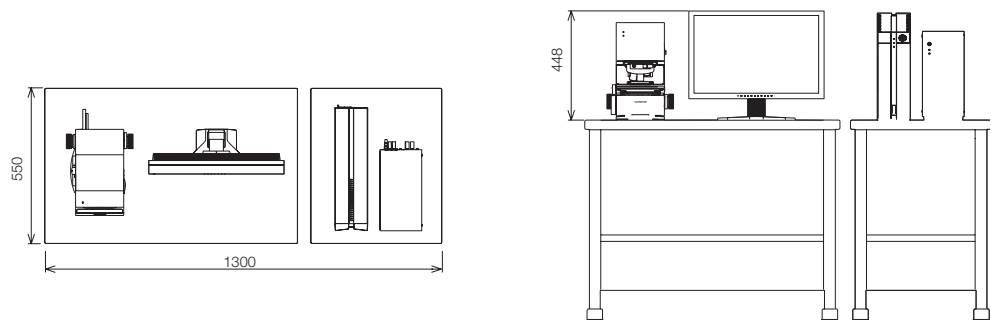

MAIN UNIT

LSM Section		Light Source/Detector	Light Source: 405 nm Semiconductor Laser, Detector: Photomultiplier
		Total Magnification	108x – 17,280x
		Zoom	Optical Zoom: 1x – 8x
Measurement	Planar Measurement	Repeatability	100x: $3\sigma_{n-1}=0.02 \mu\text{m}$
		Accuracy	Measurement Value $\pm 2\%$
	Height Measurement	System	Revolving Nosepiece Vertical-Drive System
		Stroke	10 mm
		Scale Resolution	0.8 nm
		Movement Resolution	10 nm
		Display Resolution	1 nm
		Repeatability	50x: $\sigma_{n-1}=0.012 \mu\text{m}$
Accuracy	$0.2+L/100 \mu\text{m}$ or Less (L=Measuring Length)		
Color Observation Section		Light Source/Detector	Light Source: White LED, Detector: 1/1.8-Inch 2-Megapixel Single-Panel CCD
		Zoom	Digital Zoom: 1x – 8x
Revolving Nosepiece		Motorized BF Sextuple Revolving Nosepiece	
Differential Interference Contrast Unit		Differential Interference Contrast Slider: U-DICR, Polarizing Plate Unit Built-In	
Objective		BF Plan Semi-apochromat 5x, 10x LEXT-Dedicated Plan Apochromat 20x, 50x, 100x	
Z Focusing Unit Stroke		100 mm	
XY Stage		100x100 mm (Motorized Stage), Option: 300x300 mm (Motorized Stage)	

This product is designed for use in industrial environments for the EMC performance. Using it in a residential environment may affect other equipment in the environment

OBJECTIVE SPECIFICATIONS

Model	Magnification	Field of View	Working Distance (WD)	Numerical Aperture (NA)
MPLFLN5X	108x-864x	2,560-320 μm	20.0 mm	0.15
MPLFLN10X	216x-1,728x	1,280-160 μm	11.0 mm	0.30
MPLAPON20XLEXT	432x-3,456x	640-80 μm	1.0 mm	0.60
MPLAPON50XLEXT	1,080x-8,640x	256-32 μm	0.35 mm	0.95
MPLAPON100XLEXT	2,160x-17,280x	128-16 μm	0.35 mm	0.95



LEXT

www.olympus-ims.com

OLYMPUS[®]

For enquiries - contact
www.olympus-ims.com/contact-us

OLYMPUS CORPORATION
Shinjuku Monolith, 2-3-1, Nishi-Shinjuku, Shinjuku-ku, Tokyo 163-0914, Japan
OLYMPUS EUROPA SE & CO. KG
Wendenstrasse 14-18, 20097 Hamburg, Germany
OLYMPUS SCIENTIFIC SOLUTIONS AMERICAS CORP.
48 Woerd Avenue, Waltham, MA 02453, U.S.A.
OLYMPUS MEDICAL SYSTEMS INDIA PRIVATE LIMITED.
102-B, First Floor, Time Tower, M.G. Road, Gurgaon 122001, Haryana, INDIA

OLYMPUS KOREA CO., LTD.
8F Olympus Tower, 446 Bongeunsa-ro, Gangnam-gu, Seoul, 135-509 Korea
OLYMPUS AUSTRALIA PTY. LTD.
3 Acacia Place, Notting Hill VIC 3168, Australia
OLYMPUS SINGAPORE PTE LTD.
491B River Valley Road, #12-01/04 Valley Point Office Tower, Singapore 248373
OLYMPUS (CHINA) CO., LTD.
10F, K. Wah Centre, 1010 Huai Hai Road (W), Xuhui District, Shanghai, 200031 P.R.C.

- **OLYMPUS CORPORATION is ISO14001 certified.**
- **OLYMPUS CORPORATION is ISO9001 certified.**
- All company and product names are registered trademarks and/or trademarks of their respective owners.
- Images on the PC monitors are simulated.
- Specifications and appearances are subject to change without any notice or obligation on the part of the manufacturer.