



EZ53

Tracked Zero Tail Excavators



Best performance of its class

High excavation performance even in hard to reach areas. The EZ53 is the perfect equipment for operations close to walls or buildings. The tail of the EZ53 does not reach over the undercarriage in no operating position at any time. The minimized space requirements are extremely practical on construction sites in busy city centers or on road construction sites with ongoing traffic. But not only its operating dimensions are convincing, also its material handling and digging performance are impressive.

- Remarkably higher engine and hydraulic performances plus reduced fuel consumption at the same time.
- Maintenance made easy: the tiltable cabin and the removable chassis cover provide quick and easy access, diagnostic tools offer further support.
- Perfectly equipped for multi-functional attachment tools: up to five additional control circuits with unpressurised reflux available.
- Numerous options available ex-factory such as: overload valves, idle speed autom. operation and more.



Comfortable cabin

- Spacious cabin for sufficient space for movement.
- Sliding windows on both sides. The front windscreen is divided in two. The lower screen slides up behind the upper, both screens can be moved under the cabin ceiling.



**WACKER
NEUSON**
all it takes!

Engine for highest performance

- Remarkably higher engine and hydraulic performances plus reduced fuel consumption at the same time.
- Improved digging performance and more powerful Turbo-Diesel engine provide better material handling results.



zero tail – compact all around

- Zero Tail Excavator for safe operation even in narrow spaces.
- Ideal for excavation jobs close to walls, roads, buildings or other surrounding limitations as in inner cities or busy roads.
- Optional counterweights improve stability.



VDS – vertical digging system

- The first intelligent solution for highest efficiency of excavating jobs on sloping grounds.
- VDS is available as an option for the EZ53
- VDS makes excavating particularly economical and is therefore awarded with the ECO seal.
- More details on VDS under:
wackerneuson.com/vds



Technical specifications

Operating data

Shipping weight min.	4,968 kg
Operating weight min.	5,241 kg
Biting force max.	28 kN
Breakaway force max.	38.1 kN
Digging depth max.	3,751 mm
Dumping height max.	3,837 mm
Digging radius max.	6,225 mm
Superstructure slewing speed	9.2 1/min
L x W x H	5,500 x 1,990 x 2,570 mm

Engine / Motor

Engine / Motor manufacturer	Perkins
Engine / Motor type	404D-22T
Engine / Motor	water-cooled 4-cylinder diesel engine
Displacement	2,216 cm ³
RPM / speed	1,900 rpm
Engine performance acc. to ISO	35.9 kW



Battery	88 Ah
Fuel tank capacity	83 l
Hydraulic system	
Duty pump	Double variable- & two-gear pump
Flow rate	106.4 l/min
Operating pressure for working and traction hydraulics	230 bar
Hydraulic oil tank	80 l
Wheel set	
Travel speed max.	4.5 km/h
Chain width	400 mm
Ground clearance	322 mm
Dozer Blade	
Width	1,990 mm
Height	380 mm
Stroke above ground	415 mm
Stroke below ground	455 mm
Sound level	
Sound level (LwA) acc. to 2000/14/EC	98 dB(A)
Cabin - specified sound pressure level LpA acc. to ISO 6394	77 dB(A)



Dimensions

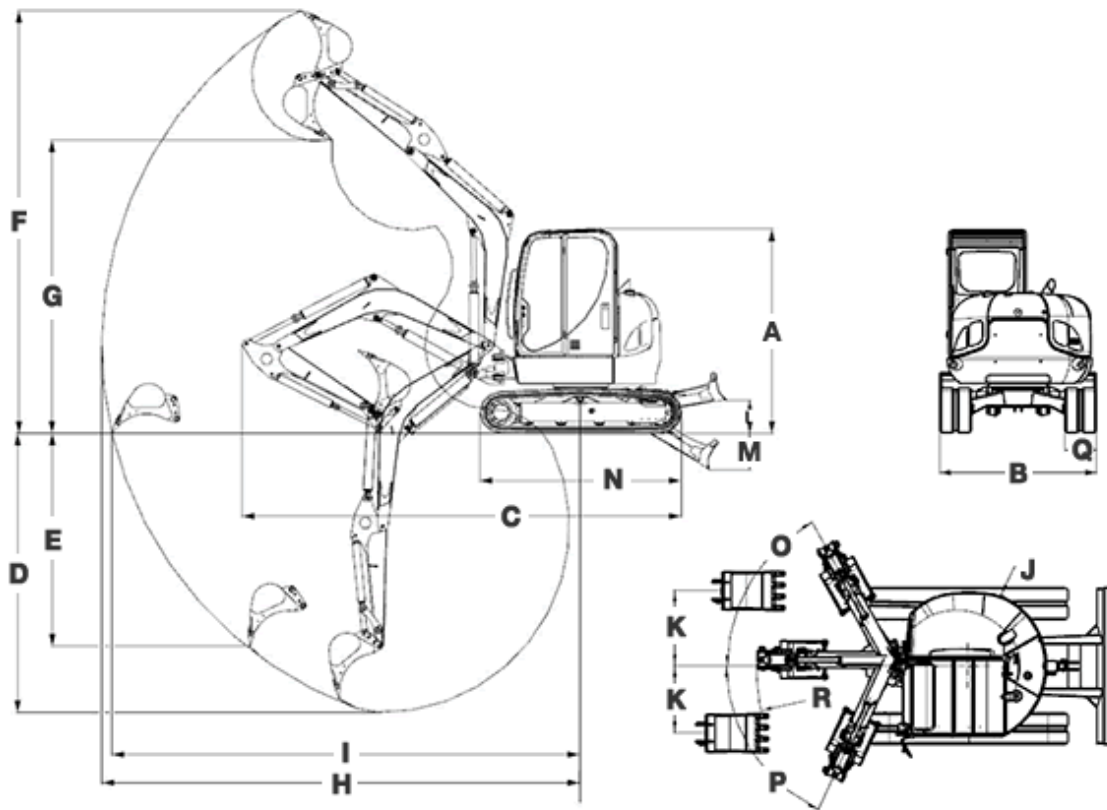

	short dipper stick	long dipper stick
A Height mm	2,570	2,570
A Height VDS mm	2,570	2,570
B Width mm	1,990	1,990
C Transport length mm	5,499	5,477
D Digging depth max. mm	3,501	3,751
D Digging depth VDS mm	3,394	0
E Insertion depth max. mm	2,667	2,906
E Insertion depth VDS mm	2,542	0
F Insertion height max. mm	5,299	5,459
F Insertion height VDS mm	5,405	0
G Dumping height max. mm	3,679	3,837
G Dumping height VDS mm	3,784	0



H	Digging radius Max. mm	5,987	6,225
H	Digging radius VDS mm	5,994	0
I	Range on the ground mm	5,860	6,104
I	Range VDS mm	5,823	0
J	Rear swivel radius min. mm	995	995
K	Arm displacement max. to middle of bucket right side mm	960	960
K	Arm displacement max. to middle of bucket left side mm	853	0
L	Lift height max. levelling blade above formation mm	415	415
M	Scraping depth max. of levelling blade below formation mm	453	453
N	Length of undercarriage mm	2,524	2,524
O	Turning angle max. arm to the right °	61	61
P	Turning angle max. arm to the left °	65	65
Q	Width tracks mm	400	400

Please note

that product availability can vary from country to country. It is possible that information / products may not be available in your country. More detailed information on engine power can be found in the operator's manual; the stated power may vary due to specific operating conditions.

Subject to alterations and errors excepted. Applicable also to illustrations.

Copyright © 2016 Wacker Neuson SE.