

• DH - 160 • DUMPER

Modelos • Models • Modèles

- DH - 160
- DH - 160 DA
- DH - 160 DG
- DH - 160 HG
- DH - 160 P

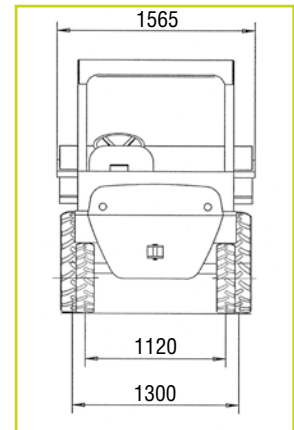

Dimensiones • Dimensions • Dimensions

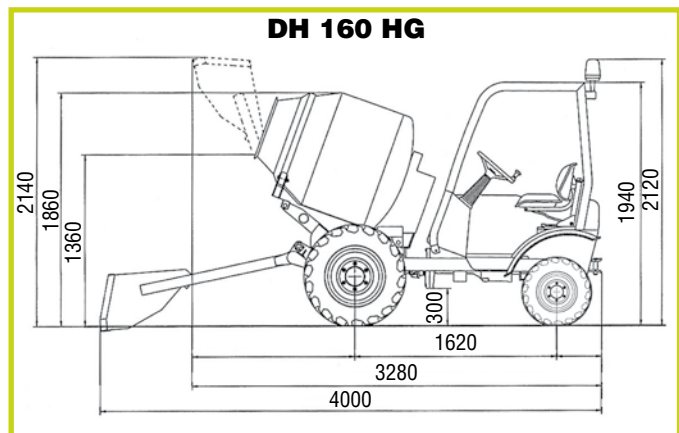
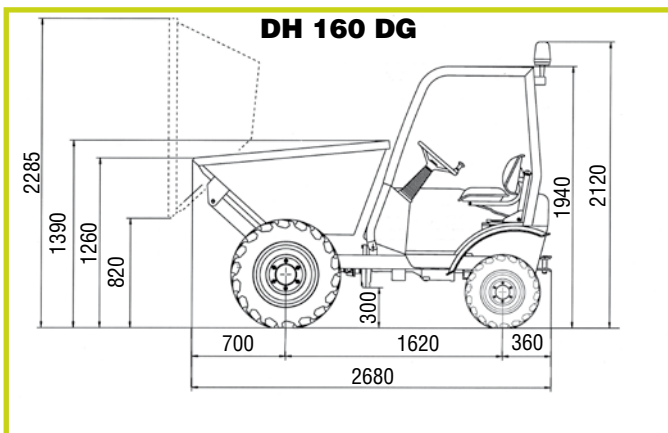
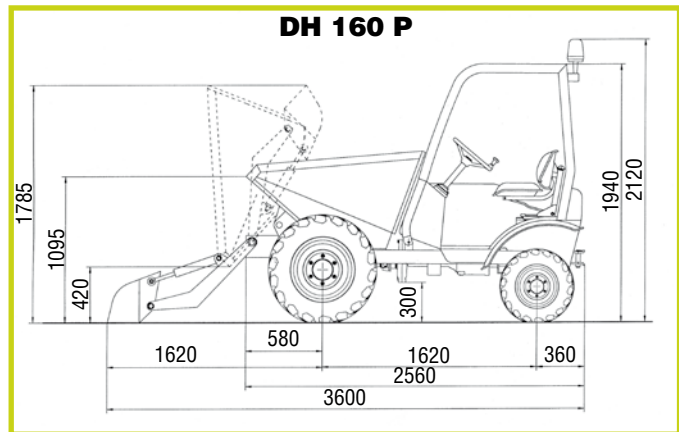
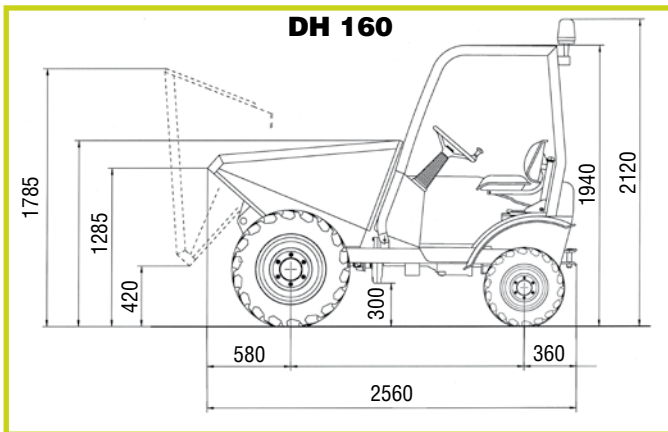

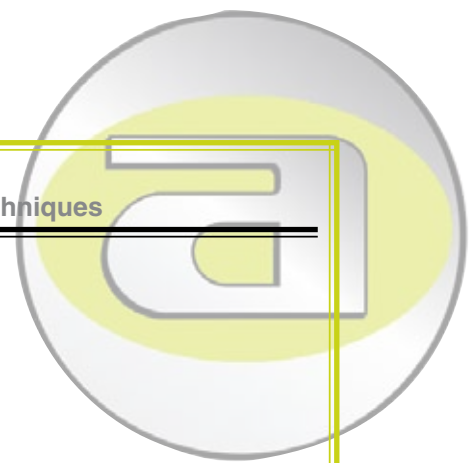

• DH - 160 • DUMPER



Características Técnicas • Technical Features • Caracteristiques Techniques

	CARGA ÚTIL (Kg.)	1.600 Kgs. • 1,05 m ³ • Nivel de agua 615 litros
	MOTOR	Lombardini, 11KW/15CV/16HP
	REFRIGERACIÓN	Agua
	ARRANQUE	Electrico
	TRACCIÓN	4 x 2 / 4 x 4 accionamiento mecánico
	VELOCIDADES	4 AV + 4 M.A. / Inversor • Velocidad máxima 23 Kms/h.
	TRANSMISIÓN	Piñón Corona
	DIRECCIÓN	Hidráulica
	FRENOS	Accionamiento hidraulico
	NEUMATICOS	DH 160 4x4 Delanteros 10.0 / 75 - 15,3 • Traseros: 20 x 8,50 / 12. • DH160 4x2:10.0 / 75 - 15,3 y 20 x 8,50 / 12
	DESCARGA HIDRÁULICA	Si
	RADIO DE GIRO (m.)	Interior: 1,60 • Exterior: 3,50
	PESO EN VACÍO (Kg.)	DH-160: 1.035 / DH-160 P: 1.140 / DH-160 HG: 1.240 / DH-160 DG: 1.120 / DH-160 DA: 1.200 Kgs.
	CARACTERÍSTICAS	Horómetro, protección antivandálica, avisador acústico de seguridad M.A., dispositivo de seguridad antiarranque, techo protector, girofaro, espejo retrovisor y cinturón de seguridad.

	USEFULL LOAD	1.600 Kgs. • 1,05 m ³ • Water level 615 liters
	ENGINE	Lombardini, 11KW/15CV/16HP
	COOLING SYSTEM	Water
	STARTER	Electrical
	TRACTION	4 x 2 / 4 x 4 working mechanically
	SPEEDS	4 forward + 4 reverse / Inversor device
	TRANSMISSION	Pinion Crown
	STEERING	Hydraulic
	BRAKES	Hydraulic drive
	TYRES	DH 160 4x4 Front: 10.0 / 75 - 15,3 • Rear: 20 x 8,50 / 12 • DH160 4x2: 10.0/75 - 15,3 and 20x8,50/12
	HYDRAULICAL DUMPING	Yes
	TURNING RADIUS (m.)	Inner: 1,60 • Outer: 3,50
	NET WEIGHT (Kg.)	DH-160: 1.035 / DH-160 P: 1.140 / DH-160 HG: 1.240 / DH-160 DG: 1.120 / DH-160 DA: 1.200 Kgs.
	FEATURES	Hour meter, rear speed acoustical adviser, anti-starter security device, protector roof, head light turning, rear -view mirror and safety belt.

	CHARGE UTILE	1.600 Kgs. • 10,5 m ³ • Niveau de eau 615 litres
	MOTEUR	Lombardini, 11KW/15CV/16HP
	REFRIGERATION	Eau
	DÉMARRAGE	Electrique
	TRACTION	4 x 2 / 4 x 4 commande mécaniquement
	VITESSES	4 avant + 4 arrière / Inverseur
	TRANSMISSION	Pignon couronne
	DIRECTION	Hydraulique
	FREINS	Entraînement hydraulique
	ROUES	DH 160 4x4 Avant: 10.0 / 75 - 15,3 • Arrière: 20 x 8,50 / 12 • DH160 4x2: 10.0/75 - 15,3 et 20x8,50/12
	DÉCHARGE HYDRAULIQUE	Oui
	RAYON DE BRACAGE (m.)	Interieur: 1,60 • Exterieur 3,50
	POIDS A VIDE (Kg.)	DH-160: 1.035 / DH-160 P: 1.140 / DH-160 HG: 1.240 / DH-160 DG: 1.120 / DH-160 DA: 1.200 Kgs.
	CHARACTERISTIQUES	Horomètre, avertisseur acoustique de sécurité marche arrière, dispositif de sécurité anti-démarrage, toit protecteur, phare tournant, miroir rétroviseur et ceinture de sécurité.