

Precision and High Speed Machines for Milling and Grinding

HIGH TECH IS OUR BUSINESS.

röders
TEC

Röders: Tradition and 200 Years of Innovation

Reliability through permanence

For over 200 years, and six generations in direct descent, Röders has been a family owned and operated company. Customers and business partners have always valued Röders as a reliable and fair partner. The company started out as a pewter manufacturer at a time when there was no industry. This tradition has been continued to the present day.

Expertise based on practical experience

Part of every pewter manufacturer is a mould shop, which serves for the production of steel cavities for casting tin. More than 30 years ago, Röders expanded and transformed its mould shop into a state-of-the-art mould production plant and began manufacturing blow moulds for PET bottles. In this production plant, Röders manufactures with highest efficiency over 5000 blow moulds annually on their own machines and with their own automation systems.





Success by innovation

Because no machine manufacturer had been able to offer machines capable of achieving the necessary cost reductions in the blow mould shop, Rödgers finally started the development of the ground-breaking High Speed Cutting technology. Rödgers brought this currently widespread manufacturing technology with high innovation to a major breakthrough. Today, more than 2500 Rödgers machines are installed worldwide.

- 1991 >> First HSC machine for mould and die making: RFM520 with PC control RMS3 (<0.1 ms block processing time, 10,000 block look ahead), feed rate of 15 m/min in the contour, spindle speed 42,000 rpm
- 1992 >> Introduction of heat shrinking technology for clamping milling tools in self-developed shrink tool holders
- 1995 >> RFM600 HSC machine with RMS6 PC-based control under Windows NT (<0.1 ms block processing time, 10,000 block look ahead, initial introduction of spline interpolation)
- 1997 >> RFM1000S – first 5-axis HSC machine
- 1999 >> Automation of HSC machines with standard industrial robots, pallet and tool change with the same robot
- 2001 >> RHP800 – with linear motors in all axes, combined with hydrostatic guideways, jig grinding and HSC milling are possible on the same machine for the first time
- 2005 >> RXP500DS – first 5-axis machine with direct drives in all axes
- 2006 >> RMSMain – extensive software for automation, controlling automated cells with several machines, connection to databases, central tool management etc.
- 2010 >> RXU1200 – first machine with patented QUADROGUIDE® concept, High Speed Cutting and High Performance Cutting in one machine
- 2012 >> RSA-60 – air bearing spindle with compared to ball bearing spindles 10 times better concentricity for highest (optical) surface qualities
- 2015 >> RACECUT®: new control and drive technology leads to drastic reduction of machining times while maintaining high surface quality



Typical Applications in Mould and Die Making

From the very beginning of its HSC machines, Röders focused on high-precision machining of complex geometries with superior surface qualities. This specialisation is the reason for the extremely high performance of all Röders' machine, drive and control technologies. In combination with the long experience of the Röders application engineers, exceptional machining results are achieved.



High performance stamping and punching tools

These tools are characterised by very high hardness and a narrow tolerance range. The high rigidity and the thermal stability of Röders HSC machines are the solid foundation for error-free HSC machining.



Die casting moulds

Die casting moulds are completely (roughing and finishing) machined with HSC directly in hardened steel. Röders HSC technology reliably achieves a surface quality and accuracy which makes bench work unnecessary, even at mould parting surfaces.

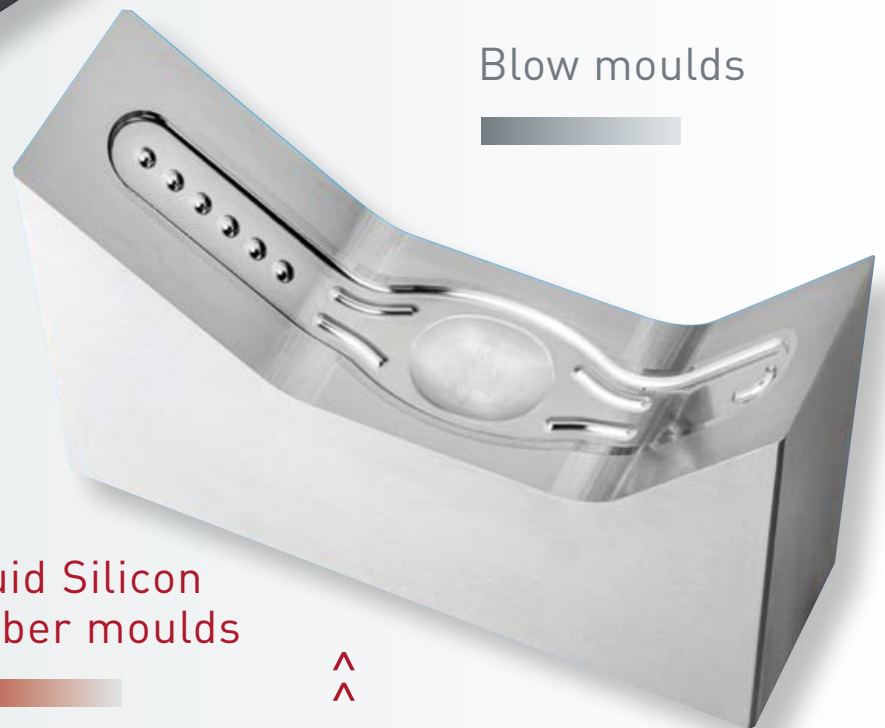

Blow moulds

Liquid Silicon Rubber moulds

Highly precise 5-axis machining,
no rework of parting surfaces necessary

Electrodes made of graphite and copper

A large number of Rödgers HSC machines (with 3 or 5 axes), often automated, are used for manufacturing high-precision electrodes which do not require any reworking. Small companies in particular make use of the advantage of being able to cut hardened steel and graphite in the same HSC machine.



Glass moulds

Shoe moulds

Continuous casting moulds



Hammer jaws

>>

∨
∨

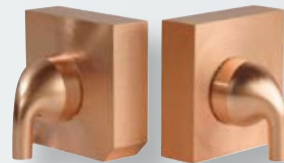

Forging dies

Reproduction of forging dies with exceptionally high dynamics on the HSC machine – extremely short machining times are achieved and reworking is not necessary

∨
∨

>>



Plastic injection moulds

Most of the Rödgers HSC machines which have been installed are used for manufacturing plastic injection moulds. The contour of the cavity and mould body itself are milled completely (roughing and finishing) in hardened steel in a single set-up. Reworking is not necessary. Due to the high accuracy of Rödgers HSC machines, spark erosion is required less and less, even for lengthy machining operations. With new milling spindles offering a maximum speed of 30,000 rpm, deep hole drilling – for example of cooling channels – is possible directly in hardened steel.

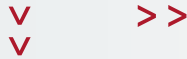

Micro-moulds

Particularly for machining micro-moulds, highest possible dynamics and precision are essential in order to achieve a significant feed rate and quality

Moulds for reflectors

Reflectors with optical surface qualities, Ra up to 5 nm



Moulds for optical components



Package moulds



Thin-walled
package moulds



Tire moulds



The focus lies on high dynamics and short
machining times with 5-axis simultaneous milling



Rubber moulds

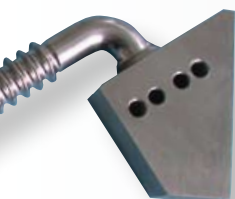

Cutting rollers

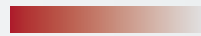

For high-precision sharpening and machining
of cutting rollers, Röders has incorporated special
functions in the control. A large number of
customers appreciate the high efficiency possible
with these functions.



<< Embossing dies



A hardness of up to 70 HRC can
be machined

Coining dies



A large number of mints worldwide value the
highly specialised knowledge of Röders in this field



Typical Applications in Manufacturing and Single Part Production

Due to the high dynamics and precision of the Rödgers HSC machines, they are increasingly used in production applications with highest requirements. The exceptional long-term precision and thermal stability are the solid foundation for reliable unattended production, resulting in extreme cost reductions.

Medical technology



Dental technology

(zircon, chromium cobalt and others)

Virtually all materials can be milled with high accuracy and very high speed on Rödgers HSC machines. Machining times often are less than 5 minutes per unit.



Optical components

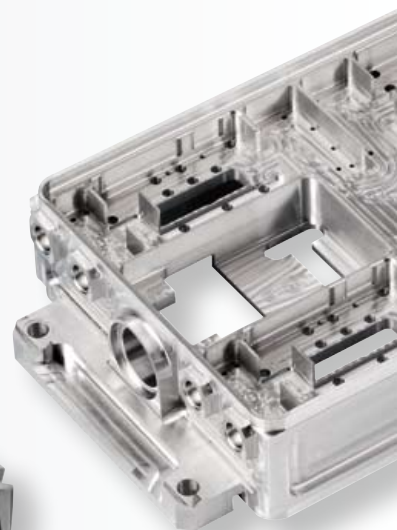

<<

Gear

Ø 450 mm, 60 HRC,
machined on RXU 1001 DSH

Design studies – prototypes



>>



Model making



<<

Blisks

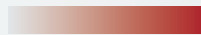

Watch industry √



Mirror surface quality on flat and rounded areas



<< Technical parts



Although typical 3D machining is not required, the high dynamics of the machines results in considerable time and cost savings.

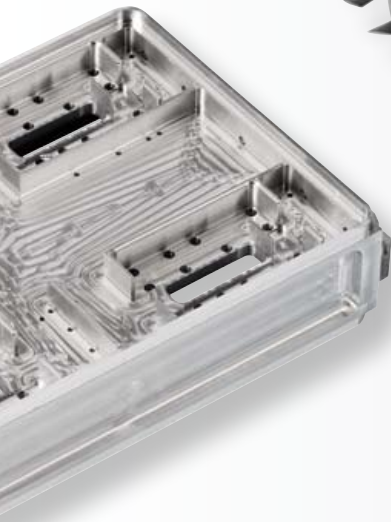

Impellers



<<

Machining time is a very important factor in the production of impellers. Machines specifically designed for this purpose are optimised for maximum dynamics and minimum mass inertia in the axes and achieve incomparably short milling times.



Design Features of the Röders Machines

Developed down to the finest detail to ensure maximum performance

The Röders machines are perfectly designed for the roughing and finishing of various kinds of materials (graphite, copper, aluminium, steel – also highly hardened – ceramics, carbide etc.). Short machining times, highest precision and best surface quality were the main targets. Complete machining in one set-up with 3 or 5 axes including deep hole drilling and thread cutting minimises the total production times. A machine technology that has been refined in every detail and with multiple patents gives the Röders HSC machines their unrivalled performance and reliability.

**Very rigid portal construction
with low moving masses**

**Patented weight compensation
for the Z axis through absolutely
frictionless vacuum hoses**



**Inherently rigid machine
frames with 3-point support**

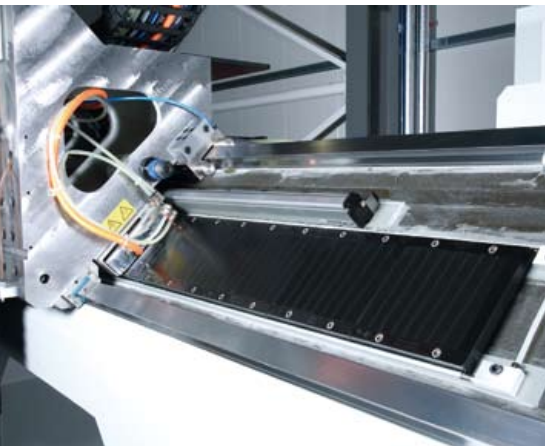

Compact, highly rigid construction

- > Linear motors in all axes for highest possible accuracy and dynamics
- > No moving parts, no wear, high reliability
- > Roller guideways for low friction, low heat generation and, at the same time, very high rigidity
- > High-precision linear scales



Very good visibility

due to large-sized windows and good accessibility to the machining area from two sides; loading with a crane possible



Large number of water circuits

- > Machines completely temperature-stabilised, due to a large number of water circuits
- > For highest precision the guiding rails and carriages are optionally temperature controlled with a water circuit directly through the rails and carriages themselves



Robot loading of tool changer

- > Chain changers also accessible for automatic loading with external tools by a robot, RCM or RC4, through a separate lift gate without interrupting machining

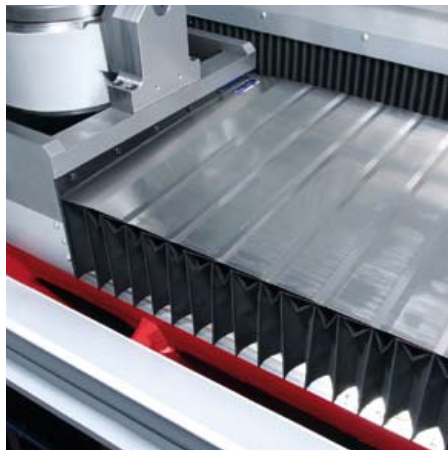

Axis covers

- > Frictionless axis covers for best possible dynamics and accuracy

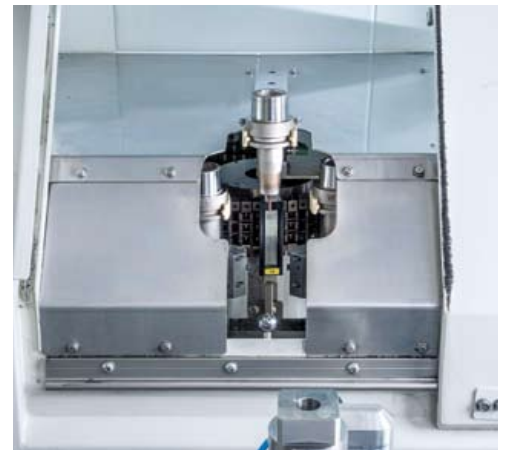

Protection against chips

- > Special precautions taken – also during tool change sequences – in order to protect all tool holders against falling chips

The Röders Control Concept

For highest performance in High Speed Cutting

The Röders RMS 6 machine control and drive technologies have continuously been developed and optimised for High Speed Cutting since 1994. The open and robust control runs on two PC-based industrial computers. With Windows 7 as the operating system, the user interface is easy to operate and requires minimal training. Numerous functionalities, some of them patented, have been integrated into the control, especially for highest performance in High Speed Cutting applications.

Only a few operating elements for extremely simple operation of the PC-based control

USB interface, industrial mouse and 19" TFT screen standard

NC-programs in ISO-format or Heidenhain®-format (with limited scope), mixed code also possible

Compatible with INDUSTRY 4.0



*Heidenhain is the registered trade mark of the Dr. Johannes Heidenhain GmbH.

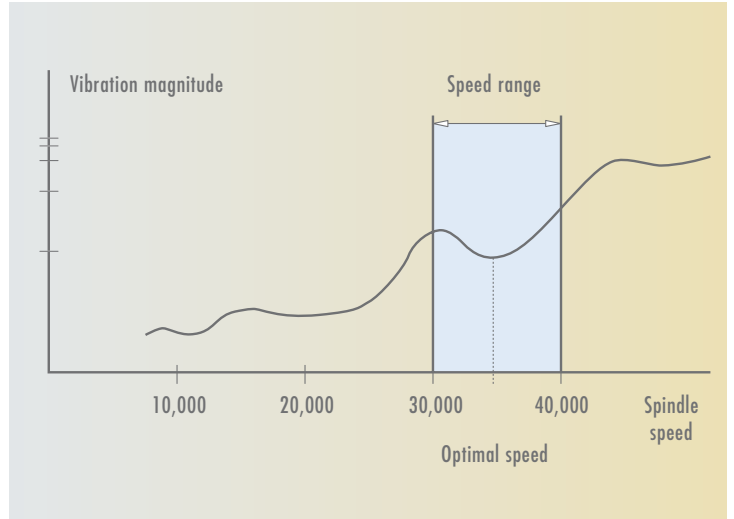
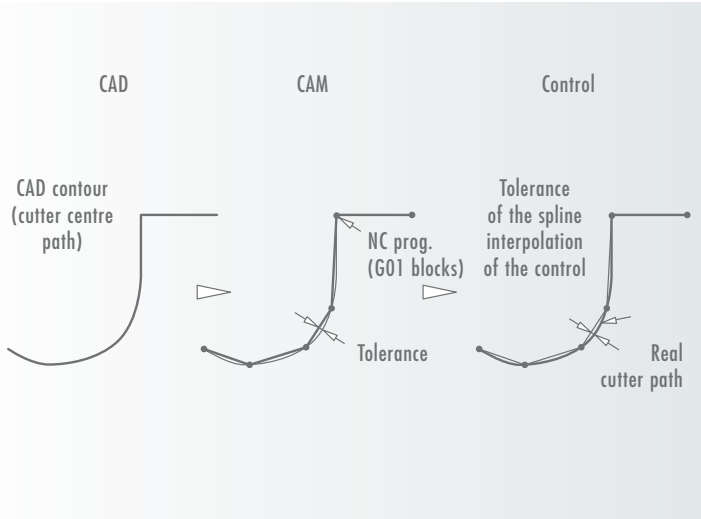

Outstanding characteristics of the Rödgers RMS6 control:

- > Block processing time < 0.1 ms
- > Look ahead > 10,000 blocks
- > Continuously improved spline interpolation

Automatic spindle speed optimisation by the machine within a user-selectable range in order to minimise vibrations and achieve the highest possible surface quality; patent pending



```

15 L X+100 Y-30 Z+50 FMAX
16 L Z+10 F1000
17 L Y+0 RR F5000
18 L IY+50
19 RND R10.5
20 L IX-50
21 CC X+50 Y+20
22 C X+20 Y+20 DR+
23 L IY-20
24 L Y -30 R0
25 L Z 50 FMAX
    
```

- > Simple individual programming of postprocessors for all CAD/CAM-systems with the help of the Rödgers postprocessor handbook
- > Standard postprocessors available at Rödgers
- > Complete output of all NC-parameters by the CAM-system
→ Programming at the machine control not necessary

- > Processing of ISO-NC-programs (G-code) or Heidenhain®*-NC-programs (with limited scope) possible
→ very short familiarization time
- > Changeover between Rödgers control and Fanuc, Siemens, Heidenhain or others very easy for operators, because the familiar NC-programing language does not change
- > Also a mixed use of ISO-NC-commands and Heidenhain®*-NC-commands is allowed



MACHINING
TIME REDUCTION

1998	1:07	18%
2001	0:55	23%
2006	0:49	27%
2009	0:39	41%
2012	0:35	47%
RACECUT®	0:27	60%

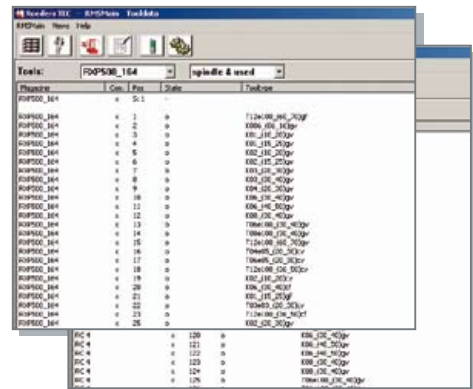

Newest control versions also for older machines (from year of manufacture 1995) available at low cost with the special Röders update service
 → Higher precision, better surface quality and significantly shorter machining times

Numerous functions for optimised use of tools

- > Sister tools
- > Wear criteria
- > Maximum tool life travel
- > Measurement strategies
- > Geometry identification and test
- > etc.

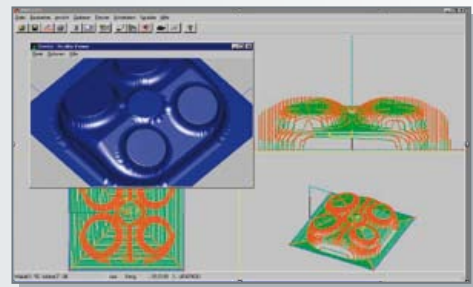
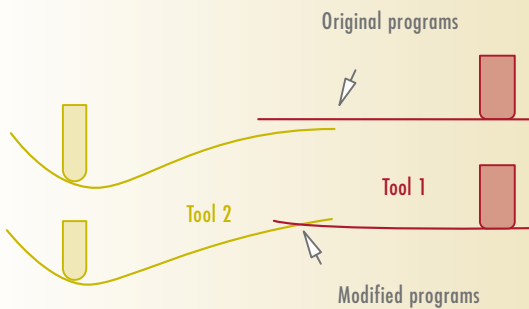

Patented function to avoid offsets in transitional areas if several different tools are used for machining

- > Automatic modification of the machining programs for tangential transitions

- > Simulation with 3D display of the workpiece
- > Very easy programming at the control in
 - > Heidenhain®*-format
 - > ISO-format
- > etc.

*Heidenhain is the registered trade mark of the Dr. Johannes Heidenhain GmbH.

Röders' own Drive Technology

High precision by shortest cycle times

The drive control of the axes is critical for the machining results, for the level of precision as well as for the surface quality. With a drive cycle frequency of 32 kHz Röders' drives have been significantly faster than others for many years. Oversampling for the encoder evaluation and many other special features achieve the highest possible axis precision and minimal energy consumption.

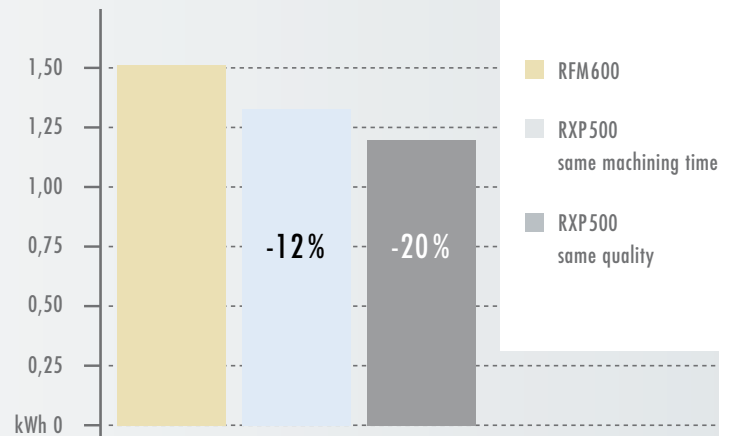

Energy-saving

With a sophisticated drive technology as well as lower friction in the axis, the linear motor technology reduces the power consumption compared to machines with ball screw drives:

- > by 12% for the same machining time
- > by 20% for the same workpiece quality

1 µm/div

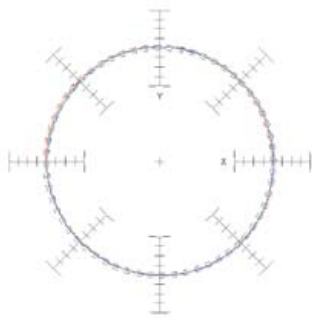

Increment 0.1 / 0.05 µm

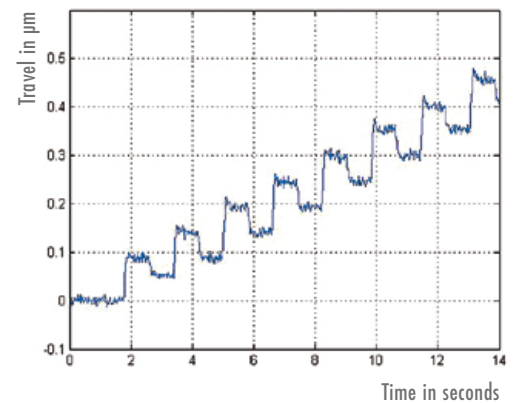

Highest precision of the machining path

- > Circular precision of < 1 µm possible

Exact temperature stabilisation

- > Hysteresis of the cooling water for temperature control of the machine < +/- 0.1 Kelvin
- > Optionally for special requirements +/- 0.02 Kelvin

Smallest increments of movement

- > Internal resolution of the control < 1 nanometre
- > Even smallest increments possible

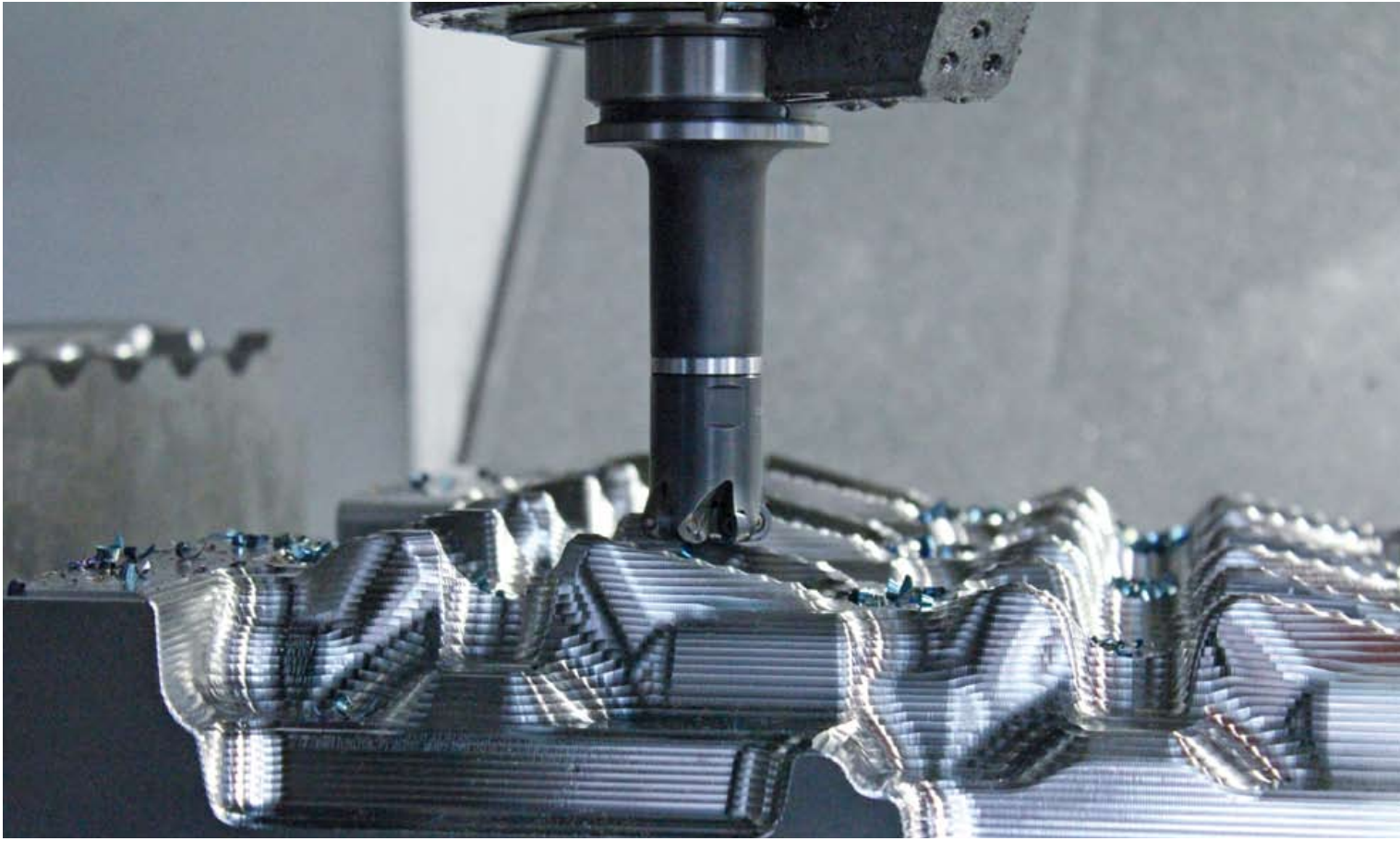

Technology for High Speed Cutting

The long-standing development of the Röders machines for High Speed Cutting resulted in many solutions concerning technical details, which are essential for the reliability and performance of the machines.

Only a few samples are presented here. Depending on the application the machines may be configured as necessary.



External compensation of the spindle elongation

- > Implemented with an accurately temperature-controlled holder attached directly in the casting of the Z axis
- > With a sensor for non-contact measurement on the rotating spindle shaft
- > Resolution in the nanometer range



Measuring laser in the tool changer

- > Measuring laser and calibration sphere located outside the machining area, where they are protected against chips and emulsion or oil



100 station tool changer

- > Self-designed tool changer solutions with various speeds and sizes up to 199 tool places



3D touch probe

- > High-precision measurement of workpieces with the 3D probe directly in the machine, cleaning with coolant before measurement possible, for automated machines optional feedback of the measuring results to the central database; retrofittable



Spray cleaning

- > Patented tool spray cleaning with solvent, followed by automatic drying for reliable, highly accurate laser measurement



Emulsion, oil and others

- > Whether dry machining, using minimal lubrication, standard coolant or oil, solutions with accurate temperature control available for all variants
- > Suction units for graphite or ceramic machining optional



Technology for Grinding

Thanks to the thorough integration of the grinding technology and the necessary auxiliary equipment, the possibilities offered by grinding as a manufacturing technology may be used without limitations and to the highest precision standards.

The long-term experience of many customers confirms the excellent profitability of combining the processes of grinding and HSC milling in a single machine.

Advantages of the Combination of Grinding and High Speed Cutting in One Machine

- > Stable machine designs allow multiple grinding strategies, which go significantly beyond the possibilities of standard jig grinding machines:
 - > Chop grinding with slow contour feed rate
 - > Contour grinding with fast contour feed rate and slow Z-motion
- > Roughing by grinding may be replaced by High Speed Cutting
 - Significant reduction of machining times
- > No offset between sections machined by High Speed Cutting and sections machined by grinding, because all operations take place in one single set-up
- > Shortening of manufacturing times, because the work-piece set-up on different machines is eliminated
- > Exact temperature control of the machining area and the workpiece with the grinding oil, also during the High Speed Cutting operations
 - No temperature fluctuation due to changing evaporative heat losses as is the case with standard coolant
- > Fits, gauges and other highly precise operations may be produced with smallest tolerances reliably and fully automatically by means of control measurements with the automatic probe of the machine
- > Extremely high surface qualities achievable
- > Very flexible, because machine may also be used as high-precision HSC machine
- > Easy to automate



Typical Application Examples



^
Carbide punch
milling of top surface, drilling, grinding of sides

▬
Gear of gear pump



∨



▬
^ Housing for a hydraulic pump
roundness of the holes < 1 µm



▬
<< Cutting tool
milling of the complete part,
5-axis grinding of cutting edge



▬
^ Camshafts ^



▬
^ Combined cutting and forming die ^
upper surface machined by High Speed Cutting,
hole manufactured by jig grinding, roundness < 0.5 µm

Technical Details

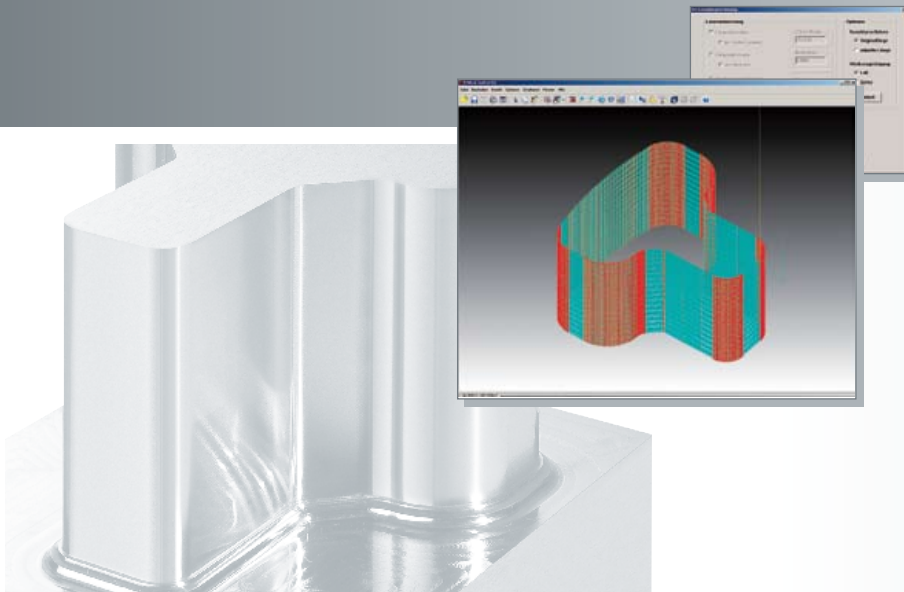

CAM programming for jig grinding

- > Very simple user interface for input of the grinding parameters at the control
- > Cycles for chop grinding and for contour grinding with slow Z-motion available
- > Externally programmed or constructed contours may be imported



Dressing of the grinding wheel at the rotating dressing spindle

- > Special cycles available for dressing
- > Preliminary measurement of the grinding wheel in the measuring laser for a "rough measurement"



Contact measurement of the grinding wheel

- The contact measurement is used for
- > precisely measuring the grinding wheel on diamond surfaces
 - > measuring the workpiece
 - > monitoring the grinding process



Grinding oil / extinguishing equipment

- > Special precisely temperature-controlled and fine-filtered grinding oil for optimal grinding results
- > Reliable extinguishing equipment for the entire machining area

Machining Spindles at Röders

For a high efficiency of the machine in the user-specific application the spindle choice is essential. Therefore, Röders offers an exceptional wide range of main spindles. By the means of a standardized interface, which has been optimized over many years, especially thermally, the main spindles are mounted in the Z-axis of the machines. This allows for a later cost-effective change to another spindle type, in case the application for the machine has changed. Options like vector control, axis cooling for high precision, lead throughs etc. are available as needed. For all spindle types Röders always has spare spindles in stock.

In case an application requires very high rpm and also a relatively powerful spindle, Röders offers the possibility to equip a machine with two main spindles. Further information can be found at: "Double Spindle Machine – Option Z2".

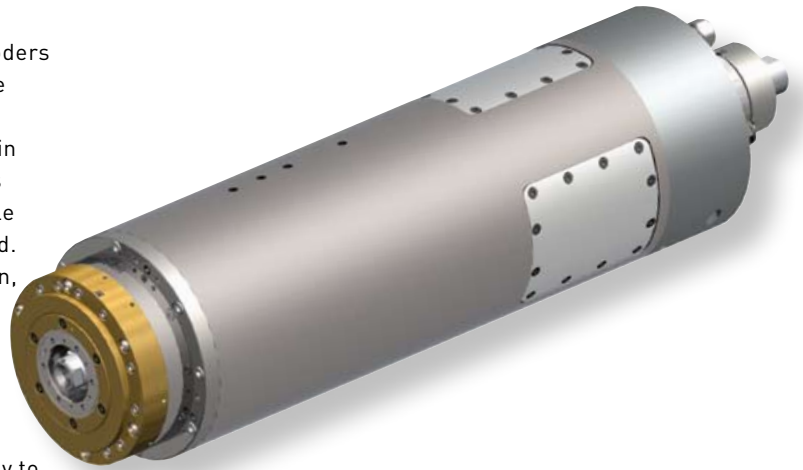

Tool Holder	Max. rpm	Torque	Bearings/Lubrication
HSK E25	90,000	0.6 Nm S1	air bearings
HSK E25	60,000	0.6 Nm S1	air bearings
HSK E25	50,000	0.9 Nm S1	ball bearings / grease
HSK E32	60,000	3.4 Nm S1	ball bearings / air-oil
HSK E32	40,000	2.4 Nm S1	ball bearings / grease
HSK E40	60,000	4.0 Nm S1	air bearings
HSK E40	45,000	5.5 Nm S1	ball bearings / axis cooling / air-oil
HSK E40	42,000	5.9 Nm S1	ball bearings / air-oil
HSK E50	36,000	12.4 Nm S1	ball bearings / axis cooling / air-oil
HSK E50	36,000	12.4 Nm S1	ball bearings / air-oil
HSK F63/E50	30,000	21.0 Nm S1	ball bearings / air-oil
HSK A63	30,000	21.0 Nm S1	ball bearings / air-oil
HSK A63	24,000	67.0 Nm S1	ball bearings / air-oil
HSK A63	22,000	101.0 Nm S1	ball bearings / air-oil

Others on request.

Important Accessories for HSC Machining

Suction devices

Röders offers powerful suction devices with all machine models for graphite, ceramics, oil mist, emulsion etc. with special filter technology.

Additional rotary axes

1-axis or 2-axis rotary tables with modern direct drive technology are quickly attached for different applications.

User-specific work piece clamping technology

For special applications, for example in automated production, Röders engineers develop specific clamping devices for directly clamping the workpieces in the machine without any pallet system.

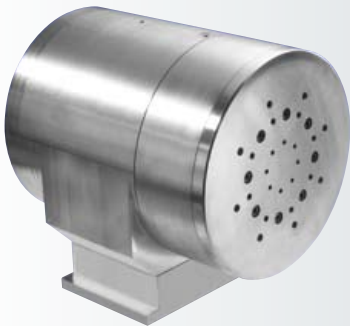

Shrink technology

Röders started using heat shrink technology for HSC machining as early as 1992. With regard to concentricity and rigidity, the heat shrink technique is unmatched even today. Röders offers its own shrinking device and tool holders for all types of spindles.

Tool holders

Important for the machining results are also the tool holders. They determine the concentricity of the tool and therewith the achievable quality of the workpiece with respect to precision and surface quality. Therefore, Röders offers high precision tool holders and may also give recommendations.

Double Spindle machine – Option “Z2”

In some applications the choice of the main spindle is difficult, because either the maximum RPM of the main spindle is not sufficient or the maximum tool size allowed in the spindle is not large enough. This affects especially machines for jig grinding, in case very small radii, for example in small holes, are to be machined with very high rpm, but also where larger tools are required for other operations.

In such cases, Röders offers the possibility to equip a machine with 2 main spindles, one more robust for larger tools and one with high rpm, for example:

- > Spindle 1: with ball bearings, HSK E50, 36,000 rpm max.
- > Spindle 2: with air bearings, HSK E25, 90,000 rpm max.

Both spindles are fully integrated in the machine so that the automatic tool changer, laser measurement, different coolants, 3D touch probe and in jig grinding machines all of the equipment for dressing, sound detection etc. are available for each spindle.



The axes of both spindles have a short distance to each other, but the spindles are highly precisely tempered with several cooling circuits. This ensures that the distance between the spindles and the positions of the spindles remain absolutely constant. As a result, in applications where both spindles are used a very high consistency of the work piece origin is achieved. Two spindles are utilized for one work piece set-up.

The option “Z2” currently is available for the machines RXP801, RXP601 DS, RXP601 DSH and all RXU machines. In the RXP machines the distance between the two spindle axes is 150 mm, in the RXU machines the distance is 225 mm. Other machine models may be equipped with two spindles upon request.

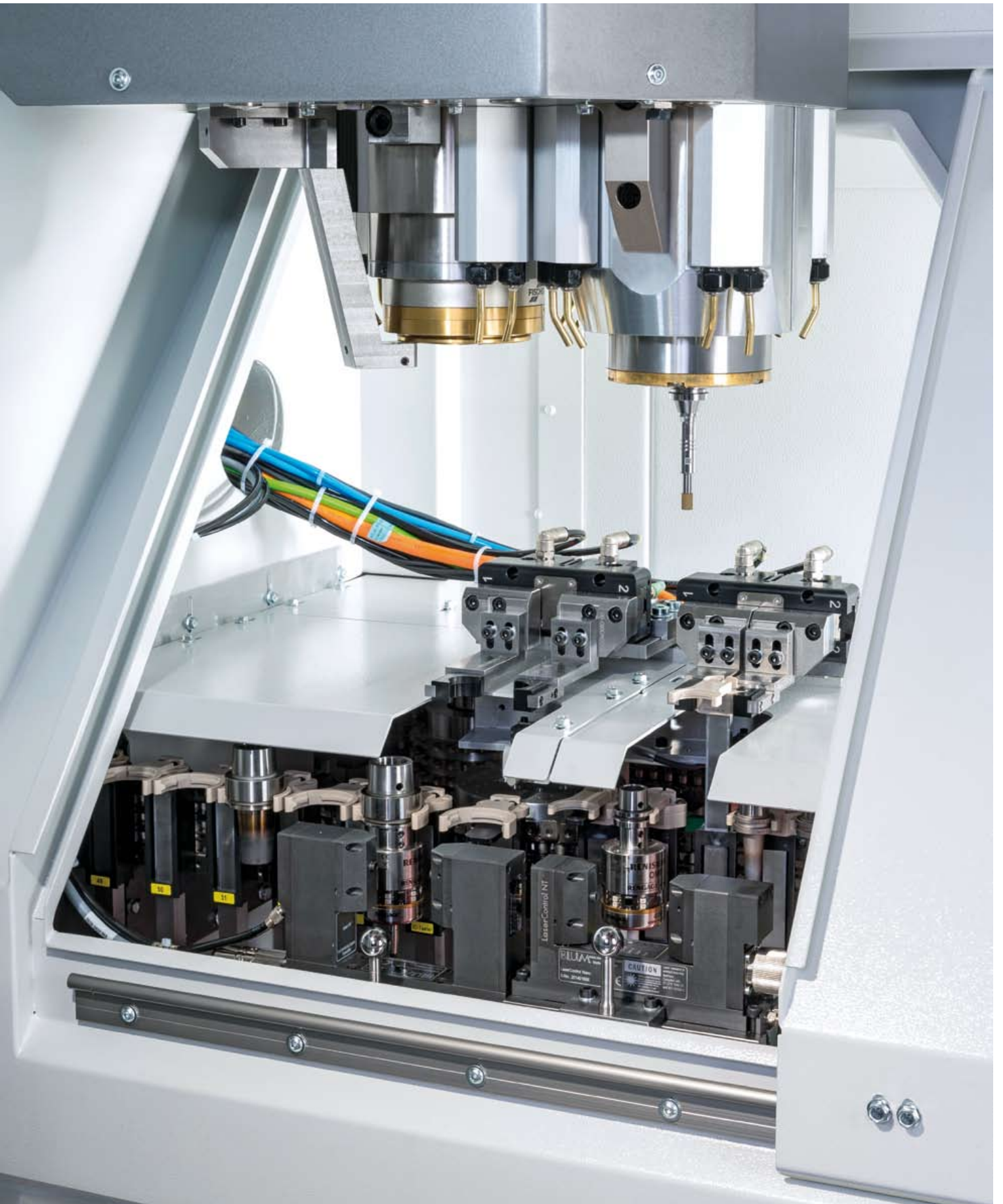

Service – More Than Just Machines

The efficiency of HSC machining depends on a variety of parameters. The HSC machine is just one of these parameters. The strong advantages and outstanding results possible with High Speed Cutting can only be achieved if all parameters are optimised.

A specialist always offers more in his field than a generalist. Therefore, Röders deliberately decided not to develop other technologies but to focus completely on HSC machining. Röders' years of experience, also in its own mould production, as well as a well-equipped application and test centre are the sound foundation for customer support.

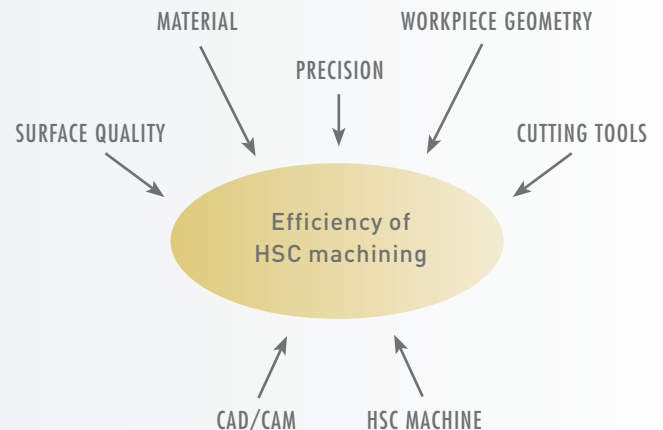

Röders has in-house CAM programmers that are proficient in the use of the leading CAD/CAM systems, and can therefore offer on-site customer support or special programming training on the customer's own CAM system. If desired, machining tests can be performed with the customer's CAM system.

High machine availability – short reaction times

The great depth of development at Röders results in exceptional efficiency also in the area of customer service. Since Röders' own specialists have detailed knowledge of all significant machine components, it is not necessary to contact suppliers for any problems which would result in waiting times. Solutions for any problems can be found quickly and efficiently with the company's own resources.

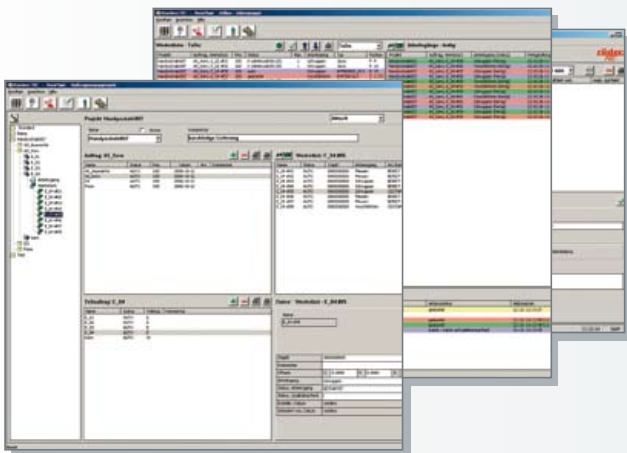

It goes without saying that Röders offers online tele-diagnostics, comprehensive machine logs etc. All this translates into a high machine availability for the customers, which is crucial for profitability, particularly with automated machines.

Röders provides a number of solutions for automating a single machine or multiple machines. Machines, handling and software (cell management and tool management) are supplied from one source, which means the responsibility lies with only one supplier. Even older machines can be automated. Further information is provided in the automation brochure.



>> Latest air conditioning technology

A highly constant temperature environment for the machine assembly, which is a prerequisite for high precision, is ensured with the latest air conditioning technology. Due to control of the floor temperature, special hose ventilation, central cold water supply to all machines to avoid local heat sources through cooling devices, highly insulated walls in the assembly hall, windows facing north only etc., temperature fluctuations are minimised and there is only a slight air flow with good air distribution.



Röders RXP 400



- Especially suitable for
- > Micro-machining
 - > Coining dies
 - > Small moulds
 - > Electrode manufacturing

Technical data

Machining range	410 mm x 294 mm x 210 mm
Table dimensions	450 mm x 300 mm, T-slots 12 mm, distance 50 mm (integrated chucks optional)
Maximum height	330 mm, between spindle nose and machine table
Workpiece weight	Maximum 100 kg
Feed	0 – 42,000 mm/min
Milling spindle (standard)	50,000 rpm, HSK E25 or 40,000 rpm, HSK E32, maximum tool diameter 6 mm for HSK E25 and 10 mm for HSK E32 (others on request)
Tool changer	18 (linear), optional 40, 70 or more places (chain changer – can be loaded during machining) integrated measuring laser
Chip disposal	In 1 chip box, optional chip conveyor
Machine weight	~3.2 t
Required space	W 2515 mm x L 1930 mm x H 2080 mm

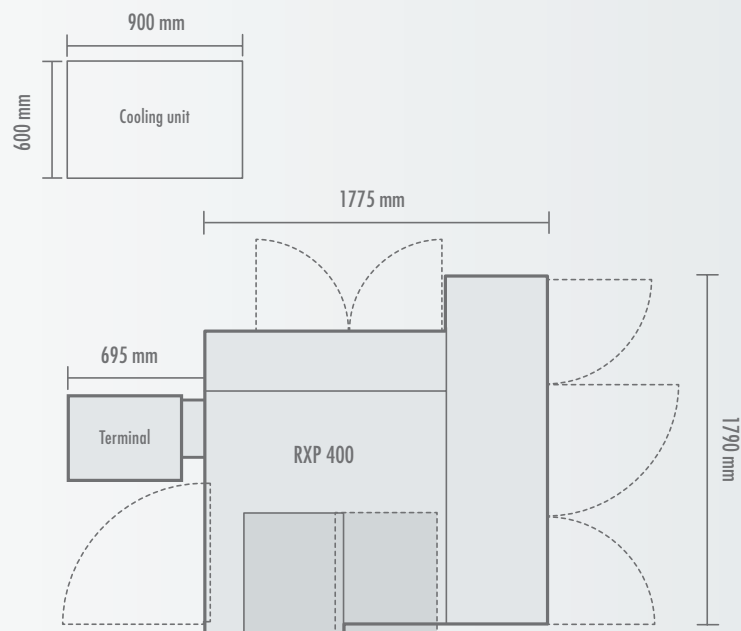

Röders RXP 400 DS

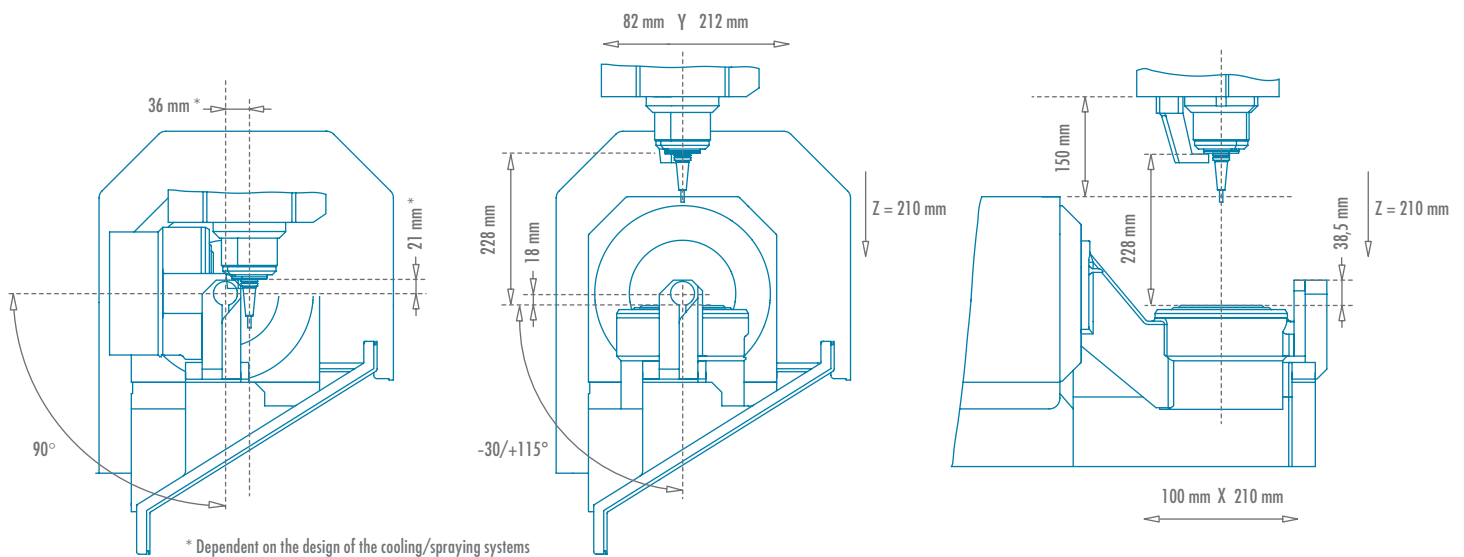

- > Highly precise micro-machining
- > Applicable for all materials
- > Electrodes, small moulds, watches etc.

Technical data

Machining range	310 mm x 294 mm x 210 mm
Swivelling range	-30/+115 degrees
Rotation range	Almost unlimited
Table size	199 mm (integrated chuck optional)
Workpiece weight	Maximum 15 kg
Feed	0 – 42,000 mm/min
Milling spindle (standard)	50,000 rpm, HSK E25 or 40,000 rpm, HSK E32, maximum tool diameter 6 mm for HSK E25 and 10 mm for HSK E32 (others on request)
Tool changer	16 (linear), optional 40, 70 or more places (chain changer – can be loaded during machining) integrated measuring laser
Chip disposal	In 1 chip box, optional chip conveyor
Machine weight	~3.2 t
Required space	W 2515 mm x L 1930 mm x H 2080 mm

- > Very efficient due to high stiffness and optimum layout of the mass inertia
- > Two-sided support of the C-axis for high stability and precision
- > High resolution optical encoders in all axes
- > Powerful wear-free direct drives in all axes
- > Special Röders 5-axis geometry compensation for high precision, also at long lasting machining operations
- > Precise temperature control of machine components
- > For dynamic decoupling, the swivelling direction is at right angles to the X axis
- > Windows very close to the machining area, visible from two sides
- > Chucks for different pallet systems can be integrated into the C-table



The machine layout is the same as for the RXP400.

Röders RXP 400 DSC

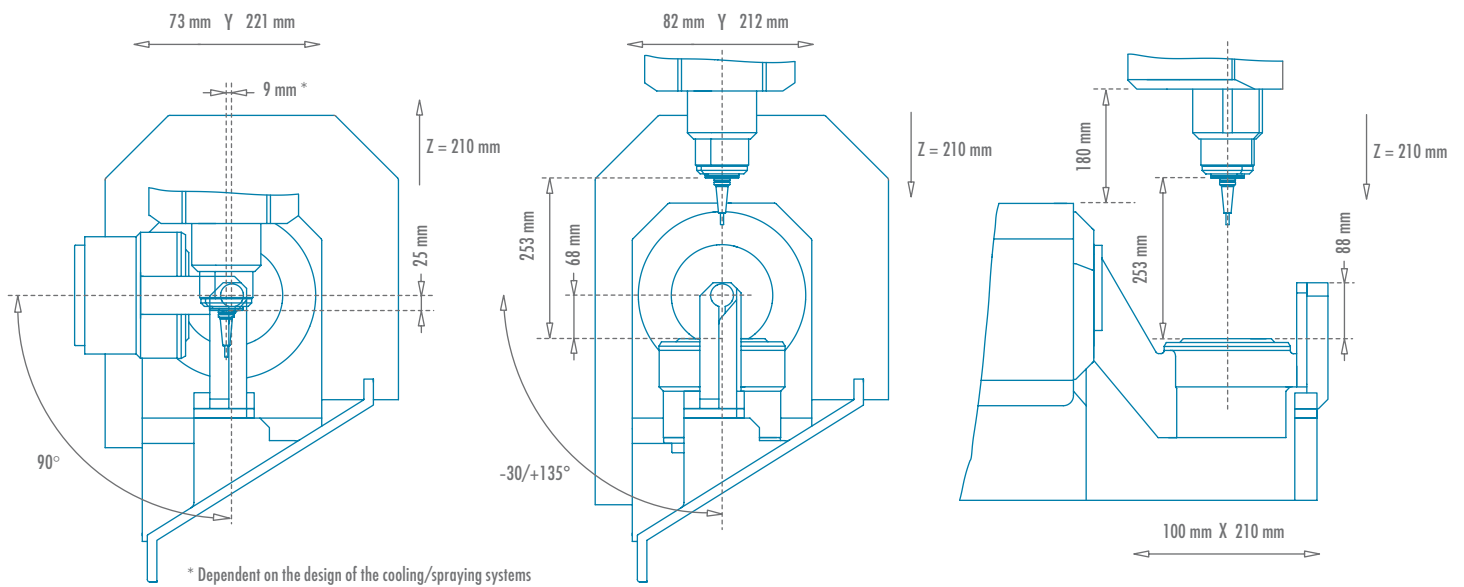

- > Large swivel range up to 135°
- > Highly precise micro-machining
- > Electrodes, small moulds, watches etc.

Technical data

Machining range	310 mm x 294 mm x 210 mm
Swivelling range	-30/+135 degrees
Rotation range	Almost unlimited
Table size	199 mm (integrated chuck optional)
Workpiece weight	Maximum 15 kg
Feed	0 – 42,000 mm/min
Milling spindle (standard)	50,000 rpm, HSK E25 or 40,000 rpm, HSK E32, maximum tool diameter 6 mm for HSK E25 and 10 mm for HSK E32 (others on request)
Tool changer	16 (linear), optional 40, 70 or more places (chain changer – can be loaded during machining) integrated measuring laser
Chip disposal	In 1 chip box, optional chip conveyor
Machine weight	~3.2 t
Required space	W 2515 mm x L 1930 mm x H 2170 mm

- > Very efficient due to high stiffness and optimum layout of the mass inertia
- > Two-sided support of the C-axis for high stability and precision
- > High resolution optical encoders in all axes
- > Powerful wear-free direct drives in all axes
- > Special Rödgers 5-axis geometry compensation for high precision, also at long lasting machining operations
- > Precise temperature control of machine components
- > For dynamic decoupling, the swivelling direction is at right angles to the X axis
- > Windows very close to the machining area, visible from two sides
- > Chucks for different pallet systems can be integrated into the C-table



The machine layout is the same as for the RXP400.

Röders RXP500



- > Compact HSC machine for medium-sized workpieces
- > Roughing and finishing in one set-up possible (also in steel)

Technical data

Machining range	500 mm x 455 mm x 240 mm
Table dimensions	550 mm x 450 mm, T-slots 14 mm, distance 50 mm
Maximum height	450 mm, between spindle nose and machine table
Workpiece weight	Maximum 400 kg
Feed	0 – 42,000 mm/min
Milling spindle (standard)	42,000 rpm, 14 kW, HSK E40, maximum tool diameter 16 mm (others on request)
Tool changer	21 (linear), optional 35 or more places (chain changer – can be loaded during machining) integrated measuring laser
Chip disposal	In 2 chip boxes, optional chip conveyor
Machine weight	~5.5 t
Required space	W 2710 mm x L 2350 mm x H 2350 mm

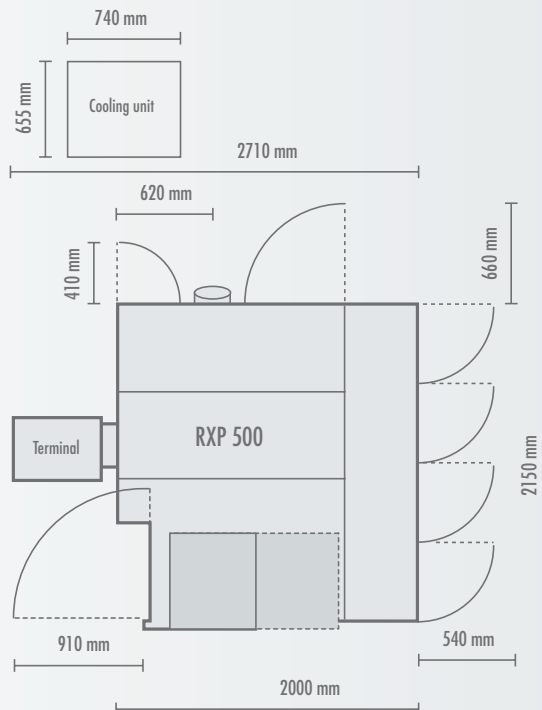

Röders RXP 500 DS

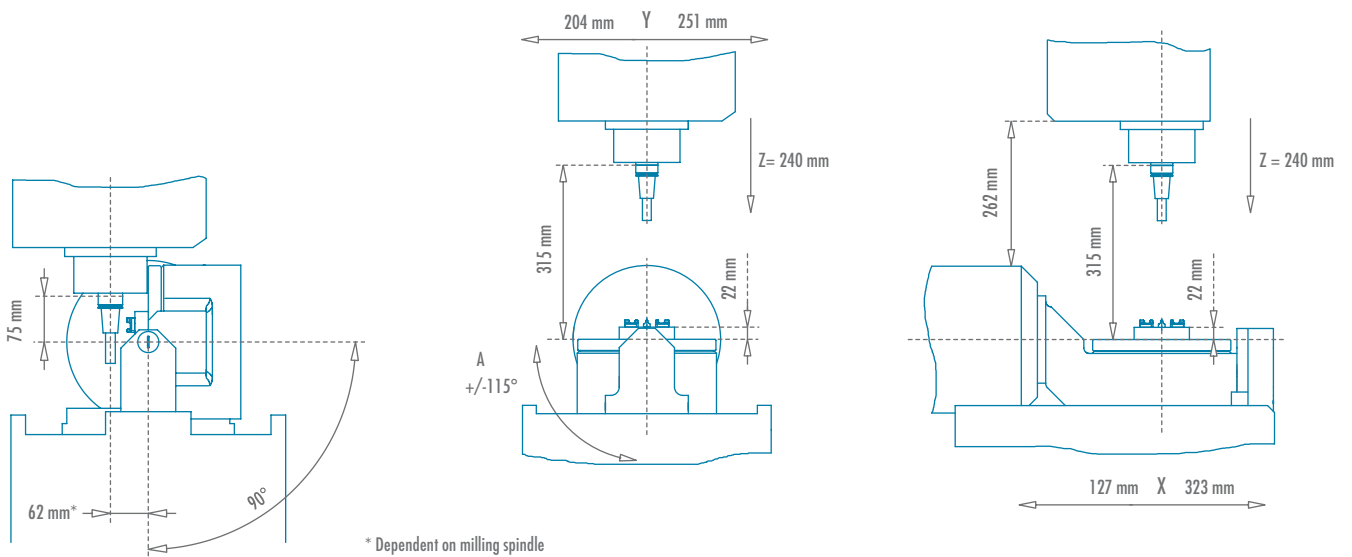

- > Compact, highly-dynamic, high precision 5-axis HSC machine
- > With second bearing for swivel axis guaranteeing high stiffness

Technical data

Machining range	450 mm x 455 mm x 240 mm
Swivelling range	+/- 115 degrees
Rotation range	Almost unlimited
Table size	250 mm (integrated chuck optional)
Workpiece weight	Maximum 60 kg
Feed	0 – 42,000 mm/min
Milling spindle (standard)	42,000 rpm, 14 kW, HSK E40, maximum tool diameter 16 mm (others on request)
Tool changer	21 (linear), optional 35 or more places (chain changer – can be loaded during machining) integrated measuring laser
Chip disposal	In 2 chip boxes, optional chip conveyor
Machine weight	~6.0 t
Required space	W 2710 mm x L 2350 mm x H 2350 mm

- > Very efficient due to high stiffness and optimum layout of the mass inertia
- > Two-sided support of the C-axis for high stability and precision
- > High resolution optical encoders in all axes
- > Powerful wear-free direct drives in all axes
- > Special Rödgers 5-axis geometry compensation for high precision, also at long lasting machining operations
- > Precise temperature control of machine components
- > For dynamic decoupling, the swivelling direction is at right angles to the X axis
- > Windows very close to the machining area, visible from two sides
- > Chucks for different pallet systems can be integrated into the C-table



The machine layout is the same as for the RXP 500.

Röders RXP 500 DSC

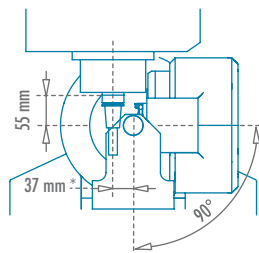

* Dependent on milling spindle

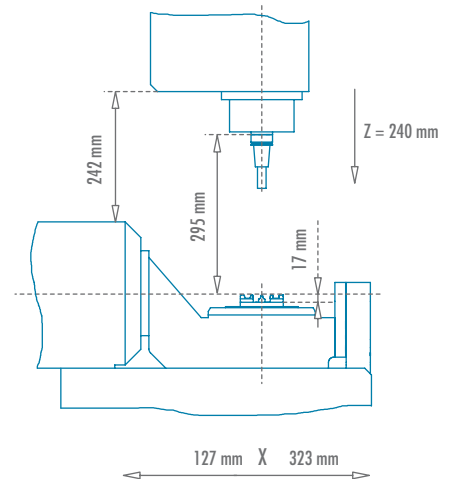
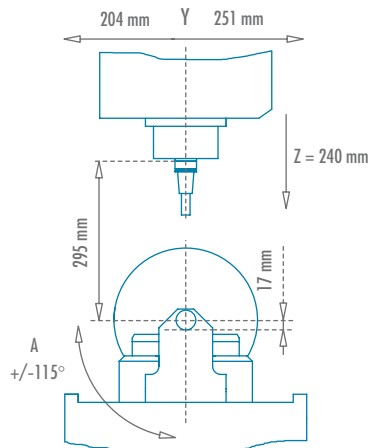

- > Optimised geometry for better machining access in operations with large swivel ranges
- > Inertia reduced further compared to the RXP 500 DS, therefore no break in the C axis
- > With second bearing for swivel axis guaranteeing high stiffness

Technical data

Machining range	450 mm x 455 mm x 240 mm
Swivelling range	+/- 115 degrees
Rotation range	Almost unlimited
Table size	200 mm (integrated chuck optional)
Workpiece weight	Maximum 30 kg
Feed	0 – 42,000 mm/min
Milling spindle (standard)	42,000 rpm, 14 kW, HSK E40, maximum tool diameter 16 mm (others on request)
Tool changer	21 (linear), optional 35 or more places (chain changer – can be loaded during machining) integrated measuring laser
Chip disposal	In 2 chip boxes, optional chip conveyor
Machine weight	~6.0 t
Required space	W 2710 mm x L 2350 mm x H 2350 mm

- > Very efficient due to high stiffness and optimum layout of the mass inertia
- > Two-sided support of the C-axis for high stability and precision
- > High resolution optical encoders in all axes
- > Powerful wear-free direct drives in all axes
- > Special Röders 5-axis geometry compensation for high precision, also at long lasting machining operations
- > Precise temperature control of machine components
- > For dynamic decoupling, the swivelling direction is at right angles to the X axis
- > Windows very close to the machining area, visible from two sides
- > Chucks for different pallet systems can be integrated into the C-table



The machine layout is the same as for the RXP 500.

Röders RXP501



- > Rigid Z-axis, large choice of machining spindles
- > Enlarged travel in all axes

Technical data

Machining range	600 mm x 500 mm x 300 mm
Table dimensions	554 mm x 450 mm, T-slots 14 mm, distance 50 mm
Maximum height	500 mm, between spindle nose and machine table
Workpiece weight	Maximum 400 kg
Feed	0 – 60,000 mm/min
Milling spindle (standard)	42,000 rpm, 14 kW, HSK E40, maximum tool diameter 16 mm (others on request)
Tool changer	35 places for HSK E40 (chain changer – can be loaded during machining), optional more places integrated measuring laser
Chip disposal	In 2 chip boxes, optional chip conveyor
Machine weight	~6.5 t
Required space	W 2800 mm x L 2450 mm x H 2520 mm

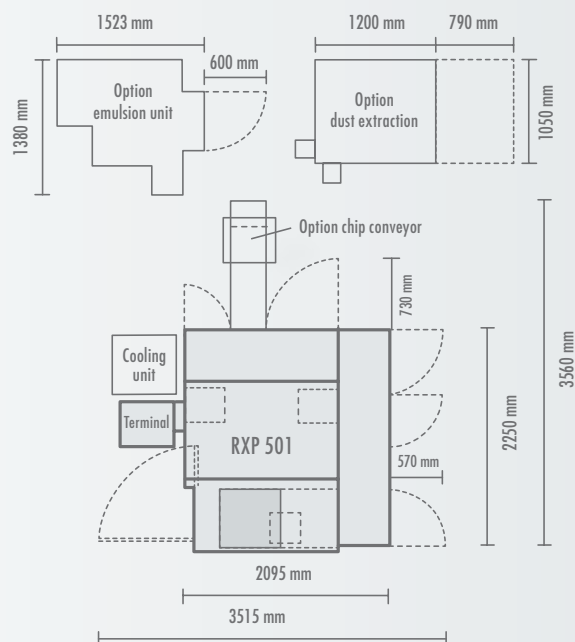

Röders RXP501 DS



Version with Erowa Power Chuck P

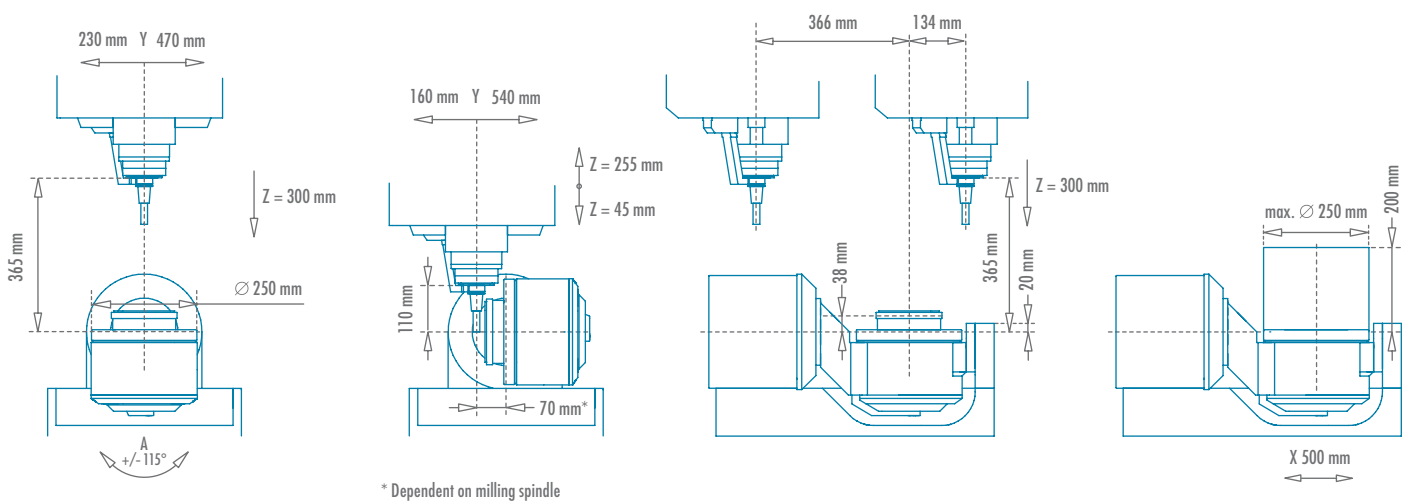

- > Compact but rigid 5-axis HSC machine
- > Large choice of machining spindles
- > With second bearing for swivel axis guaranteeing high stiffness

Technical data

Machining range	500 mm x 500 mm x 300 mm
Swivelling range	+/- 115 degrees
Rotation range	Almost unlimited
Table size	250 mm (integrated chuck optional)
Workpiece weight	Maximum 60 kg
Feed	0 – 60,000 mm/min
Milling spindle (standard)	42,000 rpm, 14 kW, HSK E40, maximum tool diameter 16 mm (others on request)
Tool changer	35 places for HSK E40 (chain changer – can be loaded during machining), optional more places integrated measuring laser
Chip disposal	In 2 chip boxes, optional chip conveyor
Machine weight	~7.0 t
Required space	W 2800 mm x L 2450 mm x H 2520 mm

- > Very efficient due to high stiffness and optimum layout of the mass inertia
- > Two-sided support of the C-axis for high stability and precision
- > High resolution optical encoders in all axes
- > Powerful wear-free direct drives in all axes
- > Special Röders 5-axis geometry compensation for high precision, also at long lasting machining operations
- > Precise temperature control of machine components
- > For dynamic decoupling, the swivelling direction is at right angles to the X axis
- > Windows very close to the machining area, visible from two sides
- > Chucks for different pallet systems can be integrated into the C-table



The machine layout is the same as for the RXP 501.

Röders RXP501 DSC



Image similar

Version with Erowa NSF Chuck

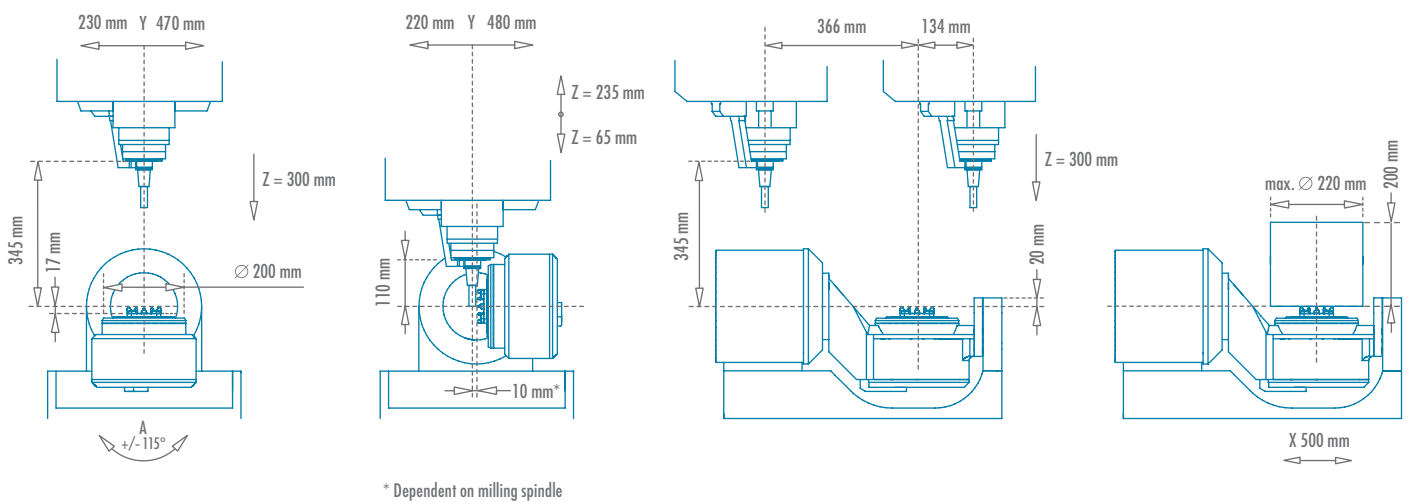

- > C-axis more eccentric compared to RXP 501 DS
- > Better access to workpiece for large swivel angles due to different geometry of C-axis
- > With second bearing for swivel axis guaranteeing high stiffness
- > No break for C-axis

Technical data

Machining range	500 mm x 500 mm x 300 mm
Swivelling range	+/- 115 degrees
Rotation range	Almost unlimited
Table size	200 mm (integrated chuck optional)
Workpiece weight	Maximum 30 kg
Feed	0 – 60,000 mm/min
Milling spindle (standard)	42,000 rpm, 14 kW, HSK E40, maximum tool diameter 16 mm (others on request)
Tool changer	35 places for HSK E40 (chain changer – can be loaded during machining), optional more places integrated measuring laser
Chip disposal	In 2 chip boxes, optional chip conveyor
Machine weight	~7.0 t
Required space	W 2800 mm x L 2450 mm x H 2520 mm

- > Very efficient due to high stiffness and optimum layout of the mass inertia
- > Two-sided support of the C-axis for high stability and precision
- > High resolution optical encoders in all axes
- > Powerful wear-free direct drives in all axes
- > Special Röders 5-axis geometry compensation for high precision, also at long lasting machining operations
- > Precise temperature control of machine components
- > For dynamic decoupling, the swivelling direction is at right angles to the X axis
- > Windows very close to the machining area, visible from two sides
- > Chucks for different pallet systems can be integrated into the C-table



Image similar. The machine layout is the same as for the RXP 501.

Röders RXP 601 DS

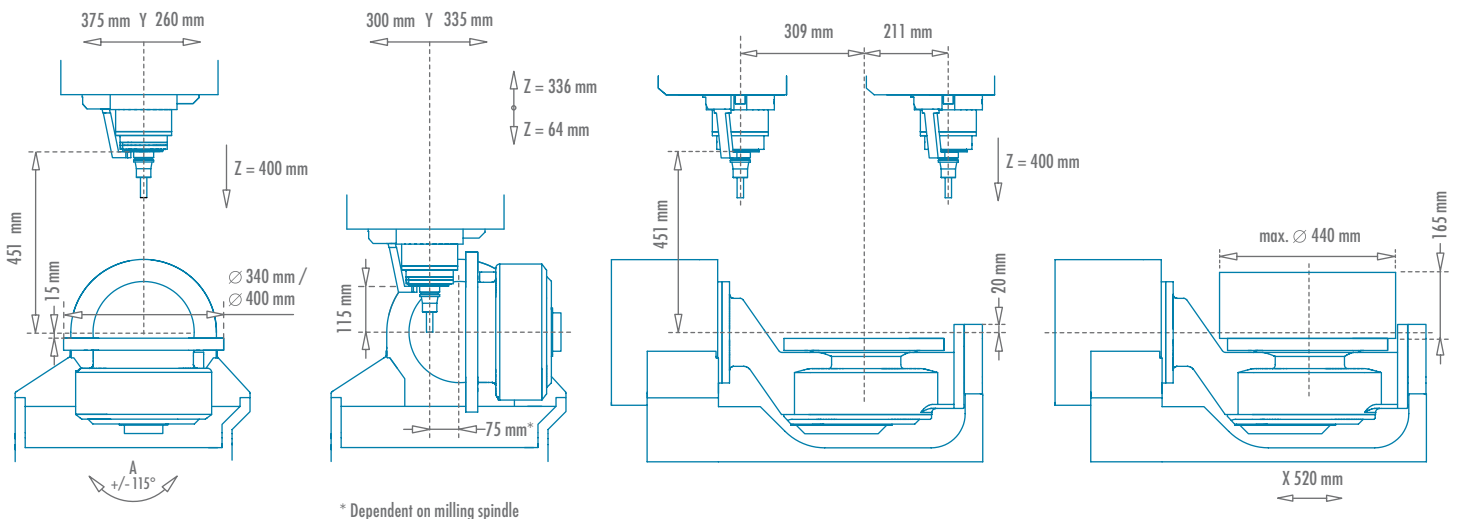

- > Highest possible dynamics through extremely powerful direct drives, also in the rotary axes
- > Highly precise due to special Röders geometry compensation
- > Standard chucks, including UPC Erowa, may be integrated
- > Machine fits into a standard container for transportation

Technical data

Machining range	520 mm x 635 mm x 400 mm
Swivelling range	+/- 115 degrees
Rotation range	Almost unlimited
Table size	340 mm round or 340 mm square 400 mm round with two flattened sides or 400 mm round
Workpiece weight	Maximum 100 kg
Feed	0 – 60,000 mm/min
Milling spindle (standard)	36,000 rpm, 15 kW, HSK E50, maximum tool diameter 20 mm
Tool changer	36 for HSK E50, optional 76 or more places (chain changer – can be loaded during machining) integrated measuring laser
Chip disposal	With 2 screws into chip box behind the machine, additional chip conveyor optional
Machine weight	~9.7 t
Required space	W 2900 mm x L 2950* mm x H 2820 / 2960** mm

- > Highly efficient due to high stiffness and optimum layout of the mass inertia
- > Two-sided support of the C-axis for high stability and precision
- > Counter bearing dimensioned for up to 4 t load
- > High resolution optical encoders in all axes
- > Powerful wear-free direct drives in all axes
- > Special Röders 5-axis geometry compensation for high precision, also at long lasting machining operations
- > Precise temperature control of machine components
- > For dynamic decoupling, the swivelling direction is at right angles to the X axis
- > Windows very close to the machining area, visible from two sides
- > Chucks for different pallet systems can be integrated into the C-table
- > Machine table for turn and swivel axis in long year proven "bowl"-shaped design



The machine layout is very similar to that of the RXP 801.

*Depending on configuration / **Depending on spindle type

Röders RXP 601 DSH

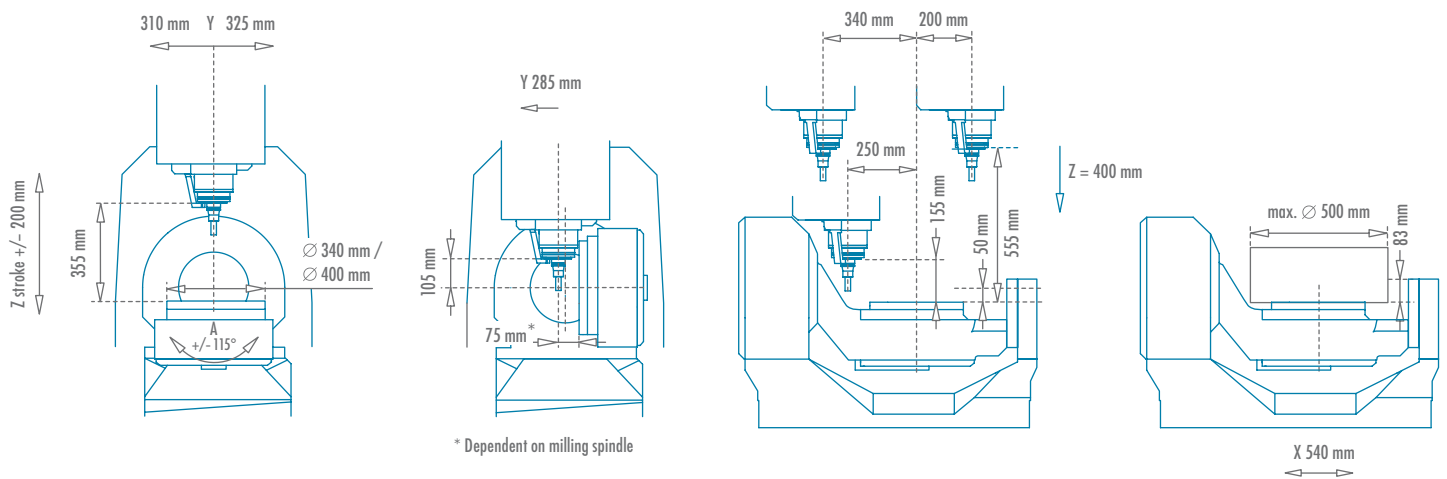

- > Highest possible dynamics through extremely powerful direct drives, also in the rotary axes
- > Highly precise due to special Röders geometry compensation
- > Maximum workpiece size in height and diameter significantly larger than on RXP601DS

Technical data

Machining range	540 mm x 635 mm x 400 mm
Swivelling range	+/-115 degrees
Rotation range	Almost unlimited
Table size	340 mm round or 340 mm square 400 mm round with two flattened sides or 400 mm round
Workpiece weight	Maximum 200 kg
Feed	0 – 60,000 mm/min
Milling spindle (standard)	36,000 rpm, 15 kW, HSK E50, maximum tool diameter 20 mm
Tool changer	36 for HSK E50, optional 76 or more places (chain changer – can be loaded during machining) integrated measuring laser
Chip disposal	With 2 screws into chip box behind the machine, additional chip conveyor optional
Machine weight	~10.2 t
Required space	W 2950 mm x L 2950* mm x H 3070 / 3210** mm

- > Highly efficient due to high stiffness and optimum layout of the mass inertia
- > Two-sided support of the C-axis for high stability and precision
- > Counter bearing dimensioned for up to 7 t load
- > High resolution optical encoders in all axes
- > Powerful wear-free direct drives in all axes
- > Special Röders 5-axis geometry compensation for high precision, also at long lasting machining operations
- > Precise temperature control of machine components
- > For dynamic decoupling, the swivelling direction is at right angles to the X axis
- > Windows very close to the machining area, visible from two sides
- > Chucks for different pallet systems can be integrated into the C-table



The machine layout is very similar to that of the RXP801.

*Depending on configuration / **Depending on spindle type

Röders RXP 801



- > Very compact machine with large machining area
- > Universally usable

Technical data

Machining range	800 mm x 635 mm x 400 mm
Table dimensions	796 mm x 596 mm
Maximum height	615 mm, between spindle nose and machine table
Workpiece weight	Maximum 800 kg
Feed	0 – 60,000 mm/min
Milling spindle (standard)	36,000 rpm, 15 kW, HSK E50, maximum tool diameter 20 mm (others on request)
Tool changer	36 for HSK E50, optional 76 or more places (chain changer – can be loaded during machining) integrated measuring laser
Chip disposal	With 2 screws into chip box behind the machine, additional chip conveyor optional
Machine weight	~8.4 t
Required space	W 2900 mm x L 2950* mm x H 2820 / 2960** mm

*Depending on configuration / **Depending on spindle type

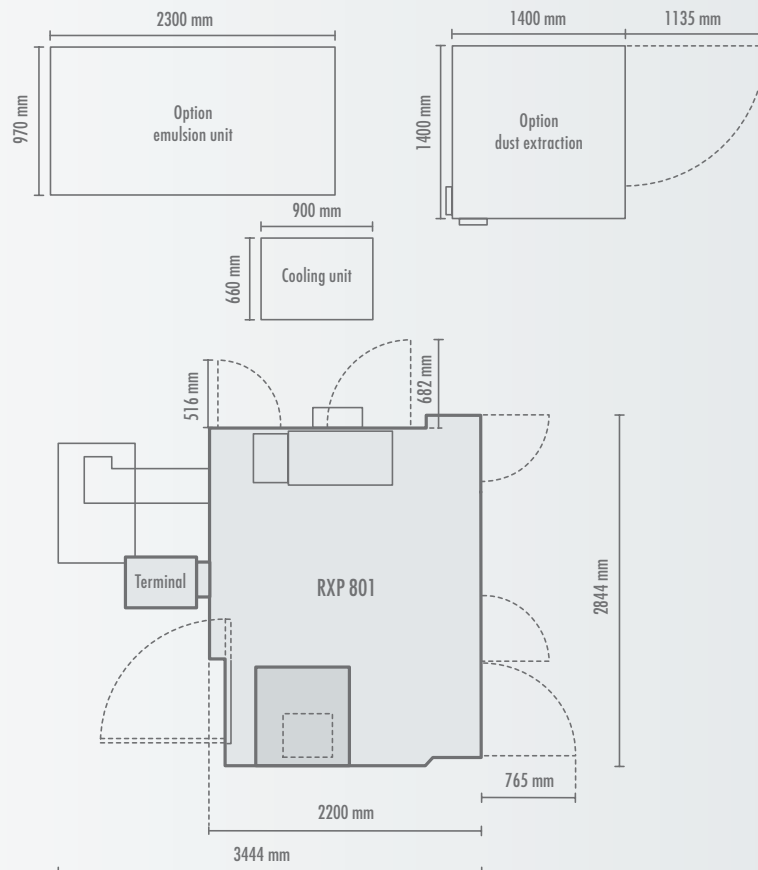

Röders RXP 950

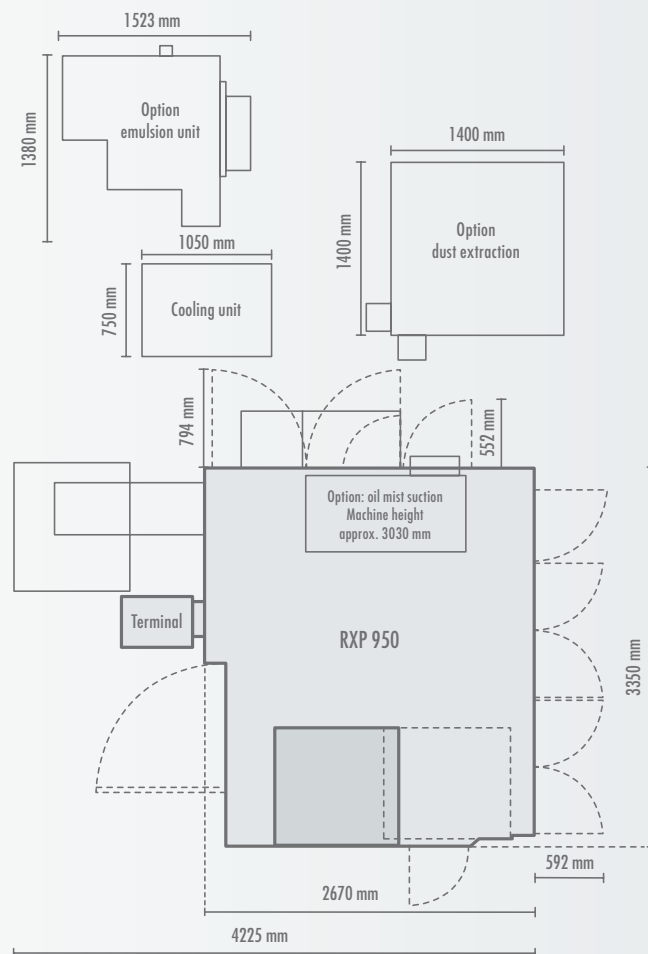

Image similar

- > Relatively large RXP machine for real High Speed Cutting
- > High dynamics due to light construction of all axes

Technical data

Machining range	950 mm x 905 mm x 500 mm
Table dimensions	950 mm x 796 mm
Maximum height	700 mm, between spindle nose and machine table
Workpiece weight	Maximum 2.000 kg
Feed	0 – 60,000 mm/min
Milling spindle (standard)	36,000 rpm, 15 kW, HSK E50, maximum tool diameter 20 mm (others on request)
Tool changer	40 for HSK E50, optional 94 or more places (chain changer – can be loaded during machining) integrated measuring laser
Chip disposal	With 2 screws into chip box behind the machine, additional chip conveyor optional
Machine weight	~14.5 t
Required space	W 3350 mm x L 3350 mm x H 3180 mm



Röders RXP 950 DSH



Image similar

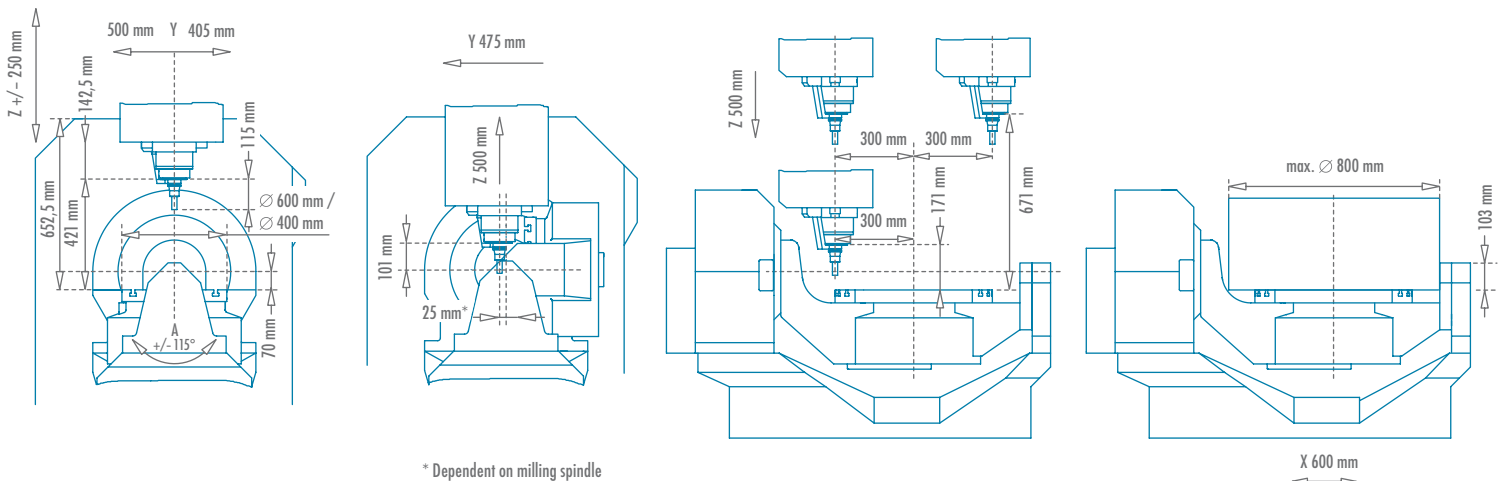

- > Highest possible dynamics through extremely powerful direct drives, also in the rotary axes
- > Highly precise due to special Röders geometry compensation
- > Strong rotary and swivel unit, identical with the one of the RXU 1001 DSH

Technical data

Machining range	600 mm x 905 mm x 500 mm
Swivelling range	+/- 115 degrees (others on request)
Rotation range	Almost unlimited
Table size	400 mm round or 400 mm square, 600 mm round with two flattened sides or 600 mm round
Workpiece weight	Maximum 800 kg
Feed	0 – 60,000 mm/min
Milling spindle (standard)	36,000 rpm, 15 kW, HSK E50, maximum tool diameter 20 mm
Tool changer	40 for HSK E50, optional 86 or more places (chain changer – can be loaded during machining) integrated measuring laser
Chip disposal	With 2 screws into chip box behind the machine or with additional chip conveyor
Machine weight	~15.5 t
Required space	W 3350 mm x L 3250* mm x H 3500 mm

- > Highly efficient due to high stiffness and optimum layout of the mass inertia
- > Two-sided support of the C-axis for high stability and precision
- > Counter bearing dimensioned for up to 7 t load
- > High resolution optical encoders in all axes
- > Powerful wear-free direct drives in all axes
- > Special Röders 5-axis geometry compensation for high precision, also at long lasting machining operations
- > Precise temperature control of machine components
- > For dynamic decoupling, the swivelling direction is at right angles to the X axis
- > Windows very close to the machining area, visible from two sides
- > Chucks for different pallet systems can be integrated into the C-table



Image similar. The machine layout is very similar to that of the RXP 950.

*Depending on configuration

RXU – QUADROGUIDE®



- New machine design: highly rigid and highly dynamic
- > High Performance Cutting and High Speed Cutting in one machine
 - > Powerfull linear and torque motors in all axes
 - > QUADROGUIDE® multi-rail concept

Quadroguide® design

- > Quadratic Z axis design with 4 guiding rails in the 4 corner edges of the Z axis
- > 8 guiding carriages in cubic arrangement on the guiding rails for optimum transmission of the forces from the Z axis
- > Y carrier with quadratic opening for Z axis
- > Extensive support of the Y carrier with additional 8 guiding carriages on the massive bridge
- > Heavy machine bodies, up to over 30 t
- > Direct drive technology in all axes
- > High resolution optical encoders in all axes
- > Patented frictionless weight compensation for Z axis

High-torque milling spindles

- > 67 Nm torque (S1 operation)
- > Maximum speed 24,000 rpm
- > Vector-controlled
- > HSK A63 interface
- > Inner tool cooling up to 80 bar
- > Double cooling system for thermal insulation
- > Spindles with higher rpm but lower torque also available

With the QUADROGUIDE® design, the machine rigidity is maximized without losses in dynamics.

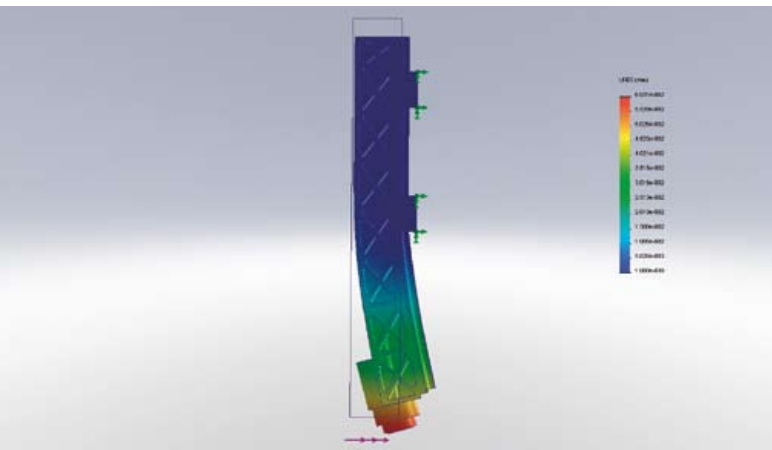

Deformation of the Z axis for standard design

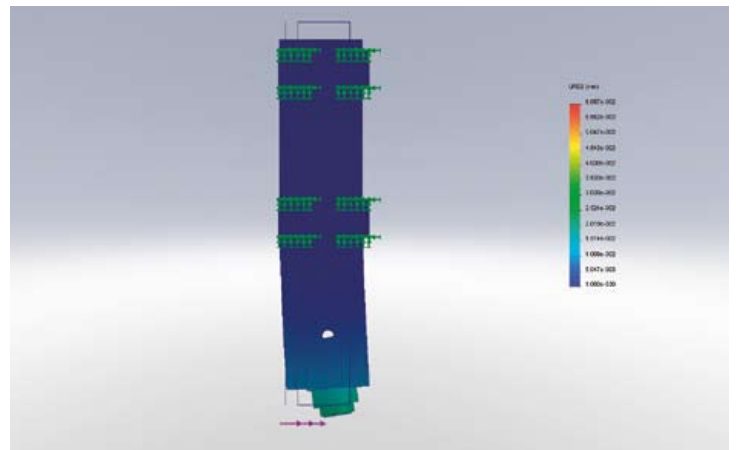

Triple rigidity due to perfect transmission of the forces from the cutter to the massive machine bridge

Röders RXU 1001 – QUADROGUIDE®



- > With QUADROGUIDE® for high roughing capacity, dynamics and precision
- > All axes with direct drives
- > Milling spindle may be chosen depending on the application, up to 101 Nm (S1) available
- > Ideal for forging dies, mould and die making, aerospace industry, medical applications, machine production and part manufacturing

Technical data

Machining range	1000 mm x 810 mm x 500 mm
Table dimensions	996 mm x 798 mm
Maximum height	700 mm between spindle nose and machine table, 680 mm clearance between machine table and portal
Workpiece weight	Maximum 2,000 kg
Feed	0 – 60,000 mm/min
Milling spindle (standard)	24,000 rpm, 67 Nm (S1), HSK A63, maximum tool diameter 35 mm (others on request)
Tool changer	24 (rotary – can be loaded during machining), optional 40, 75 or more places (chain changer – can be loaded during machining), integrated measuring laser
Chip disposal	With 2 screws into chip box behind the machine or with additional chip conveyor
Machine weight	~19.5 t
Required space	W 3500 mm x L 4814* mm x H 3300 mm

*With HC-E / depending on configuration

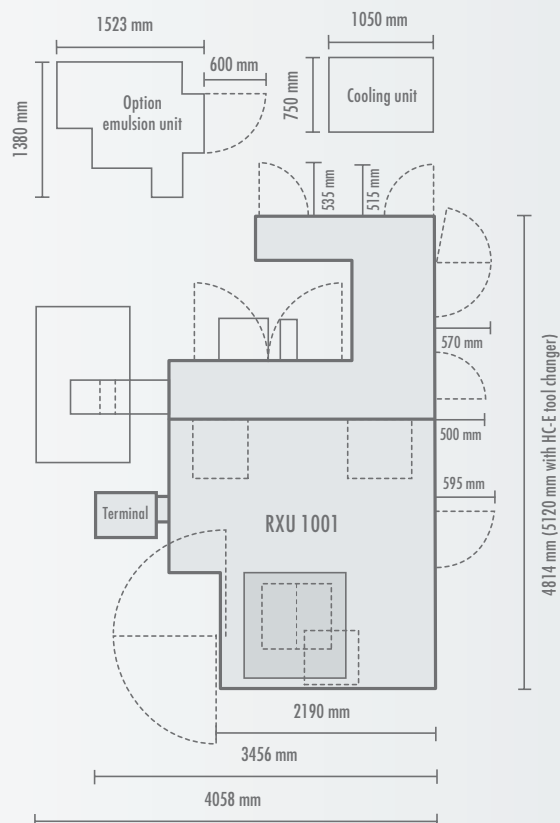

Röders RXU 1001 DSH – QUADROGUIDE®

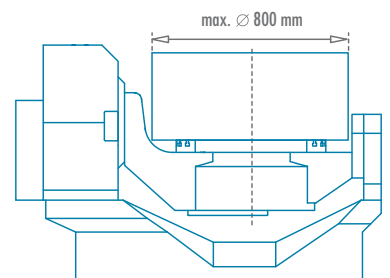
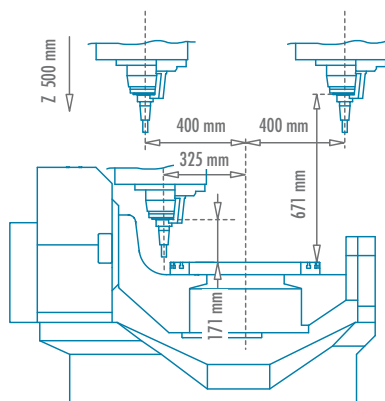
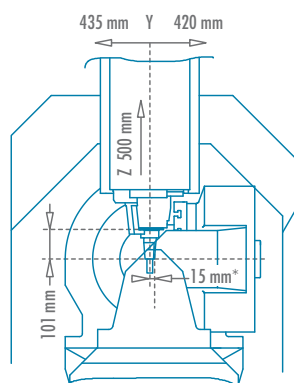
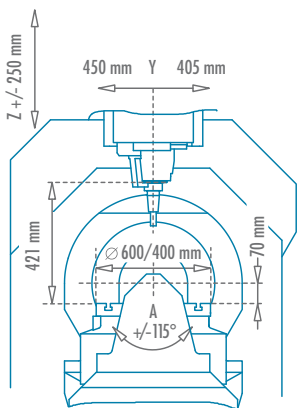

* Dependent on milling spindle

- > With QUADROGUIDE® for high roughing capacity, dynamics and precision
- > All axes with direct drives
- > Milling spindle may be chosen depending on the application, up to 101 Nm (S1) available
- > Compared to the RXU 1000 DSH the travel in X-direction and the maximum workpiece diameter are increased, the offset of the C-axis is higher

Technical data

Machining range	800 mm x 855 mm x 500 mm
Swivelling range	+/- 115 degrees (others on request)
Rotation range	Almost unlimited
Table size	400 mm round or 400 mm square, 600 mm round with two flattened sides or 600 mm round
Workpiece weight	Maximum 800 kg
Feed	0 – 60,000 mm/min
Milling spindle (standard)	24,000 rpm, 67 Nm (S1), HSK A63, maximum tool diameter 35 mm (others on request)
Tool changer	24 (rotary – can be loaded during machining), optional 40 or more places (chain changer – can be loaded during machining), integrated measuring laser
Chip disposal	With 2 screws into chip box behind the machine or with additional chip conveyor
Machine weight	~21.0 t
Required space	W 3500 mm x L 4814* mm x H 3600 mm

- > Highly efficient due to high stiffness and optimum layout of the mass inertia
- > Two-sided support of the C-axis for high stability and precision
- > Counter bearing dimensioned for up to 7 t load
- > High resolution optical encoders in all axes
- > Powerful wear-free direct drives in all axes
- > Special Röders 5-axis geometry compensation for high precision, also at long lasting machining operations
- > Precise temperature control of machine components
- > For dynamic decoupling, the swivelling direction is at right angles to the X axis
- > Windows very close to the machining area, visible from two sides
- > Chucks for different pallet systems can be integrated into the C-table



The machine layout is very similar to that of the RXU 1001.

*Depending on configuration

Röders RXU 1201 DSH – QUADROGUIDE®



Image similar

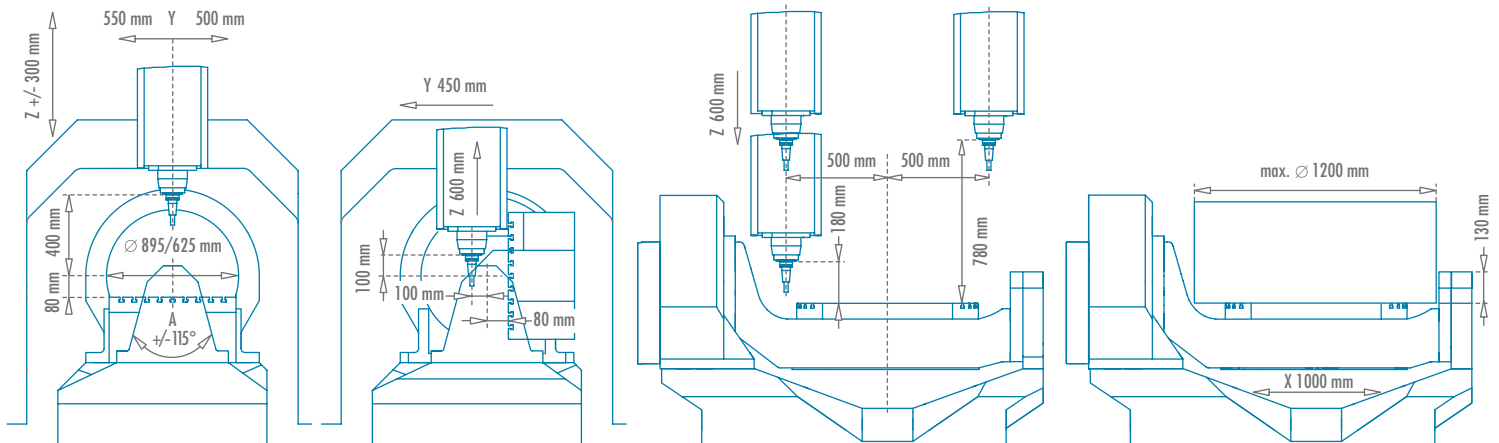

- > With QUADROGUIDE® for high roughing capacity, dynamics and precision
- > All axes with direct drives
- > Milling spindle may be chosen depending on the application, up to 101 Nm (S1) available
- > Ideal for forging dies, mould and die making, aerospace industry, medical applications, machine production and part manufacturing

Technical data

Machining range	1000 mm x 1050 mm x 600 mm
Swivelling range	+/- 115 degrees (others on request)
Rotation range	Almost unlimited
Table size	625 mm round or 625 mm square, 895 mm round with two flattened sides or 895 mm round
Workpiece weight	Maximum 1,500 kg
Feed	0 – 60,000 mm/min
Milling spindle (standard)	24,000 rpm, 67 Nm (S1), HSK A63, maximum tool diameter 35 mm (others on request)
Tool changer	50, optional 90 or more places (chain changer – can be loaded during machining) integrated measuring laser
Chip disposal	With 4 screws in the working area in chip box or chip conveyor behind the machine
Machine weight	~33.0 t
Required space	W 4126 mm x L 5431* mm x H 4000 mm

- > Highly efficient due to high stiffness and optimum layout of the mass inertia
- > Two-sided support of the C-axis for high stability and precision
- > Counter bearing dimensioned for up to 20 t load
- > High resolution optical encoders in all axes
- > Powerful wear-free direct drives in all axes
- > Special Röders 5-axis geometry compensation for high precision, also at long lasting machining operations
- > Precise temperature control of machine components
- > For dynamic decoupling, the swivelling direction is at right angles to the X axis
- > Windows very close to the machining area, visible from two sides
- > Chucks for different pallet systems can be integrated into the C-table



The machine layout is very similar to that of the RXU 1401.

*Depending on configuration

Röders RXU 1401 – QUADROGUIDE®



Image similar

- > With QUADROGUIDE® for high roughing capacity, dynamics and precision
- > All axes with direct drives
- > Milling spindle may be chosen depending on the application, up to 101 Nm (S1) available
- > Ideal for forging dies, mould and die making, aerospace industry, medical applications, machine production and part manufacturing

Technical data

Machining range	1400 mm x 1050 mm x 600 mm
Table dimensions	1400 mm x 1070 mm, T-slots 14 mm, distance 80 mm
Maximum height	800 mm, between spindle nose and machine table
Workpiece weight	Maximum 3,000 kg
Feed	0 – 60,000 mm/min
Milling spindle (standard)	24,000 rpm, 67 Nm (S1), HSK A63, maximum tool diameter 35 mm (others on request)
Tool changer	50, optional 90 or more places (chain changer – can be loaded during machining) integrated measuring laser
Chip disposal	With 2 screws into chip box behind the machine or with additional chip conveyor
Machine weight	~27.0 t
Required space	W 3921 mm x L 5439* mm x H 3600 mm

*Depending on configuration

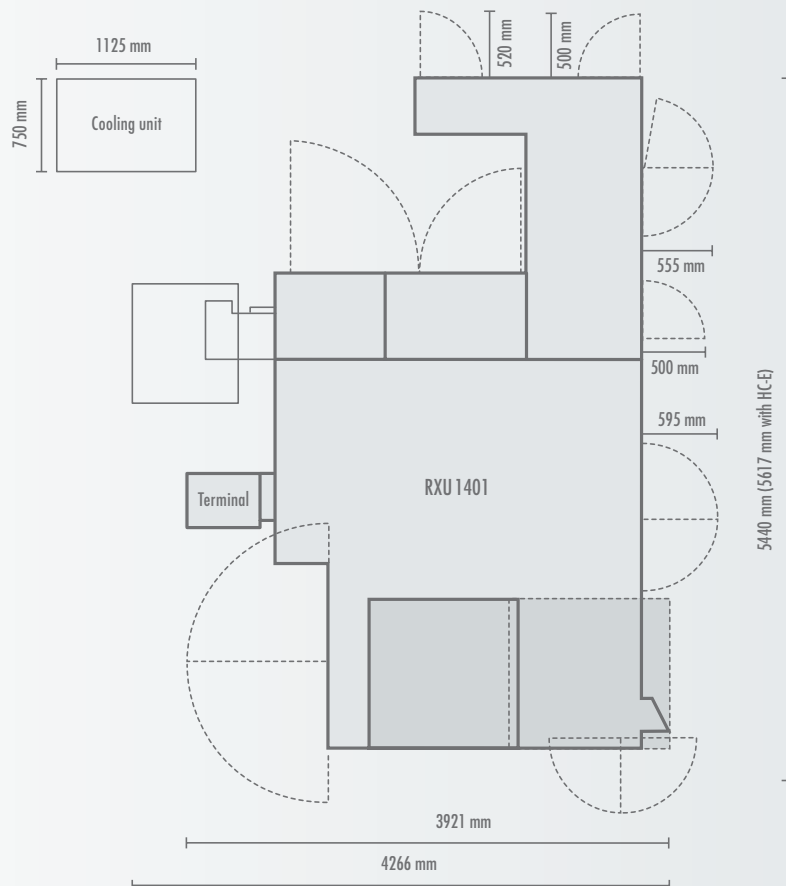

Röders RXS 500 DSI/ -DSI2



Highly dynamic 5-axis machines

- > Lightweight construction
- > Stronger motors for the greatest possible dynamics
- > Accelerations ranging to over 3 g

The Machine Concept of the RXS Series

The RXS series represents the logical advancement of the RXP machines for applications in which achieving the best possible dynamics is of the utmost priority for absolute minimisation of the machining times. As far as possible, the moving elements in the axes were designed as rigid yet lightweight aluminium structures. At the same time, much larger motors were integrated, allowing the machines to attain extremely high accelerations in all axes.

The RXS 500 DSI2, also with 5 axes, was designed as a dual-spindle machine without tool changer. This type is thus the ideal choice for series-produced parts for which only two tools

are needed, e.g. in impeller machining. The non-productive times consist only of the parts changes, which can be carried out while the spindles are running.

To compensate for small tolerances in the clamping position of the workpiece, the workpiece can optionally be touched by the rotating tool immediately before machining, so that the position may be sensed – accurate to the μm – by a sound detection device.

Of course, Rödgers also implements the automation of these machines, preferentially by means of industrial robots. For the RXS 500 DSI2 this includes the tool change functionality by the automation. In addition, interfaces to higher-ranking production control systems are feasible.



Machining area of the RXS 500 DSI2, set up for impeller machining

Röders RXS 500 DSI

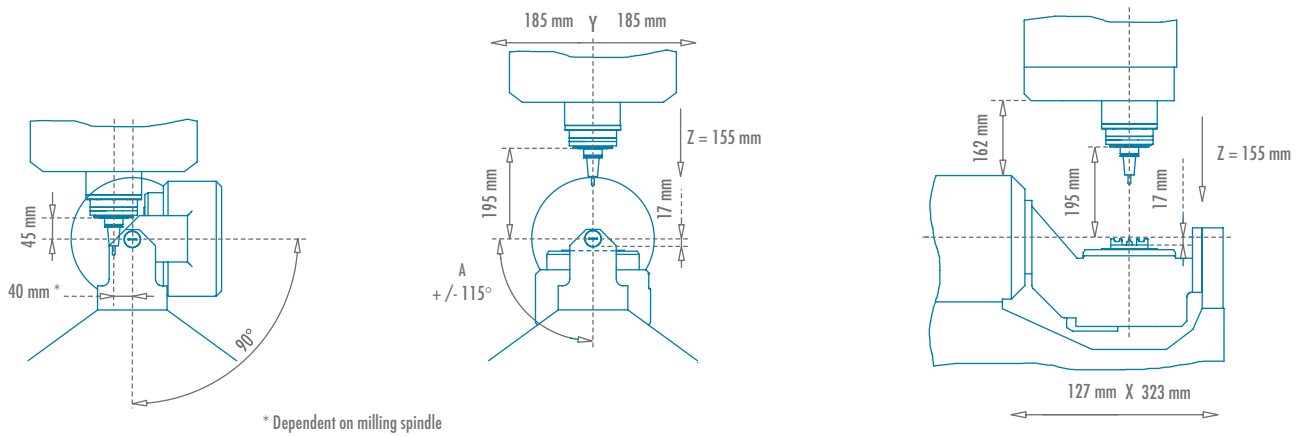

Single-spindle machine with fast tool changer

Röders RXS 500 DSI 2

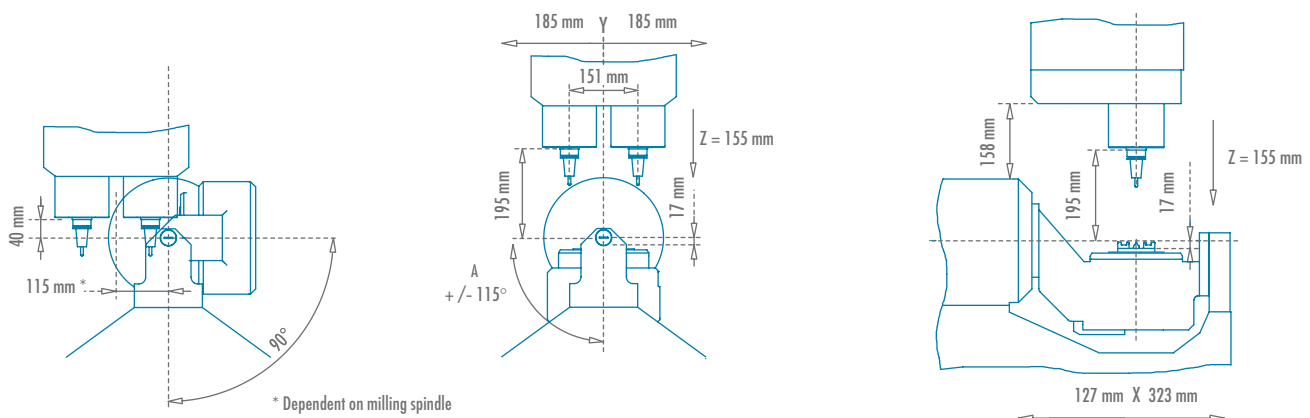

Dual-spindle machine without tool changer, positioning range limited

The options of the RXP series, such as automatic tool measurement, emulsion coolant and lead-through for inner tool cooling, are available for both machine types. Special chucks for direct clamping of e.g. impellers can be integrated into the table.

Technical data	RXS 500 DSI	RXS 500 DSI 2
Machining range	450 mm x 370 mm x 155 mm	450 mm x 370 mm x 155 mm
Swivelling range	+/-115 degrees	+/-115 degrees
Rotation range	Almost unlimited	Almost unlimited
Table size	200 mm	200 mm
Workpiece weight	Maximum 10 kg	Maximum 10 kg
Feed	0 – 42,000 mm/min	0 – 42,000 mm/min
Milling spindle (standard)	42,000 rpm, 14 kW, HSK E40, vector-controlled for short acceleration times, maximum tool diameter 16 mm (others on request)	2 spindles, both 42,000 rpm, 14 kW, HSK E40, maximum tool diameter 16 mm (others on request)
Tool changer	26, optional 54 places (chain changer – can be loaded during machining)	Optionally for right spindle
Measuring laser	Integrated in tool changer	Accessible by both spindles
Chip disposal	With scraping conveyer into chip trolley	With scraping conveyer into chip trolley
Machine weight	~6.0 t	~6.0 t
Required space	W 3110 mm x L 2350 mm x H 2320 mm	W 3110 mm x L 2350 mm x H 2350 mm

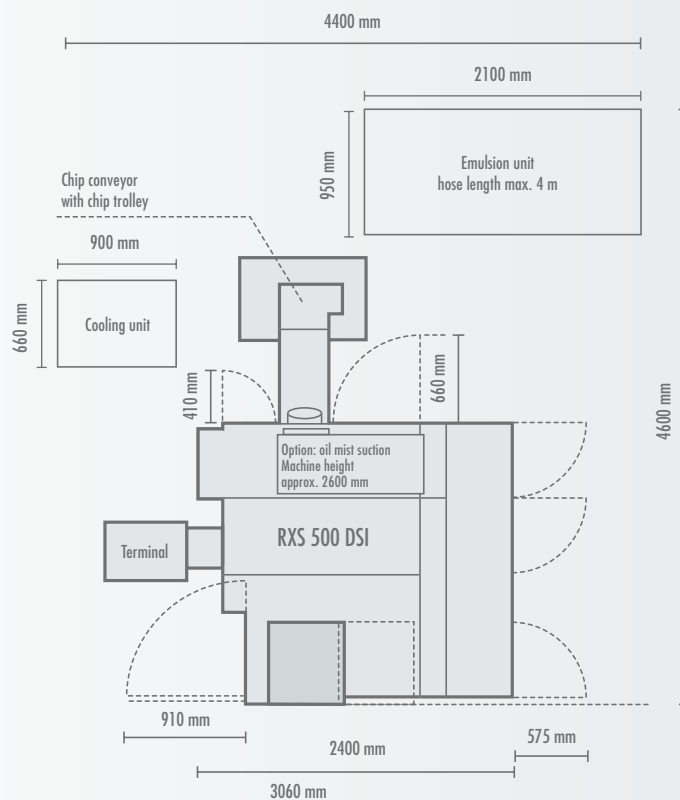

The RXS 500 DSI 2 is 200 mm narrower than the RXS 500 DSI.

The Machine Concept of the RHP Series

The RHP machines differ from the RXP machines in terms of the guideway concept. Hydrostatic guideways in all axes improve the running performance significantly:

- > Micro-movements across the travelling direction of the axes in the sub-micrometre range, as encountered with roller guideways, are reliably prevented.
 - > The controlled hydrostatic oil film between the moving slide and the guideways provides additional damping.
 - > The precise temperature control of the hydrostatic oil is effective directly at the guideways, prevents temperature fluctuations and hence thermally caused deformation of the machine geometry.
- > Because the axis covers and weight compensation for the Z axis (patented) are optimised for minimum friction, the axes exhibit an ideal drive control response.

The fundamental technology of the RHP machines corresponds to that of the RXP series: linear motors in all axes, Röders RMS6 control, exact temperature stabilisation, compensation of the spindle elongation etc.



- > Hydrostatic axis construction with hydrostatic guideways pretensioned by the magnetic field of the linear motor
- > High-precision glass scales with a position resolution of 1 nanometre
- > Wear- and friction-free

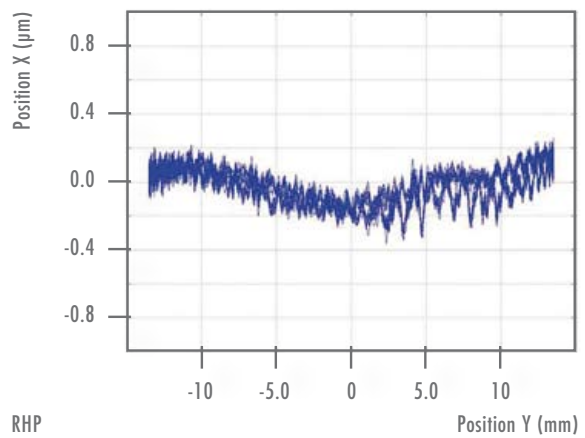
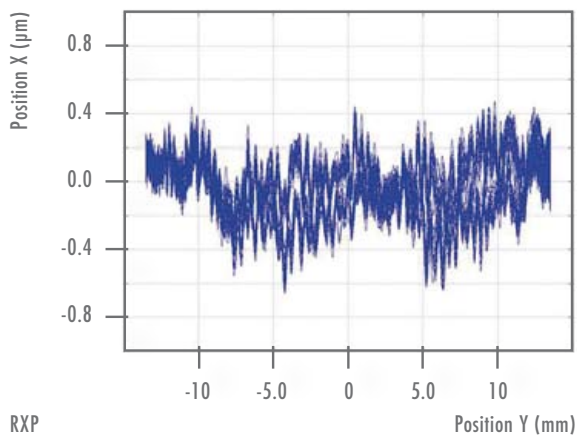

Less micro-movements across the travel direction and therefore a much smoother running of the axis slide with hydrostatic guideways in comparison to guideways with roller or ball bearings

Options

The manifold options for the RXP series are also available for the RHP machines, e.g. rotary swivel units for 5-axis machining etc. The RHP machines are excellently suited to the combination of HSC milling and grinding.



Röders RHP 500



- > Highest possible precision, both static and dynamic
- > For particularly high surface qualities
- > Compact machine for medium-sized workpieces

Technical data

Machining range	500 mm x 552 mm x 300 mm
Table size	600 mm x 540 mm
Maximum height	455 mm, between spindle nose and machine table
Workpiece weight	Maximum 400 kg
Feed	0 – 60,000 mm/min
Milling spindle (standard)	42,000 rpm, 14 kW, HSK E40, maximum tool diameter 16 mm (others on request)
Tool changer	42 places (chain changer – can be loaded during machining) integrated measuring laser
Chip disposal	With 2 screws into chip box behind the machine, additional chip conveyor optional
Machine weight	~10.0 t
Required space	W 3015 mm x L 2510 mm x H 2750 mm

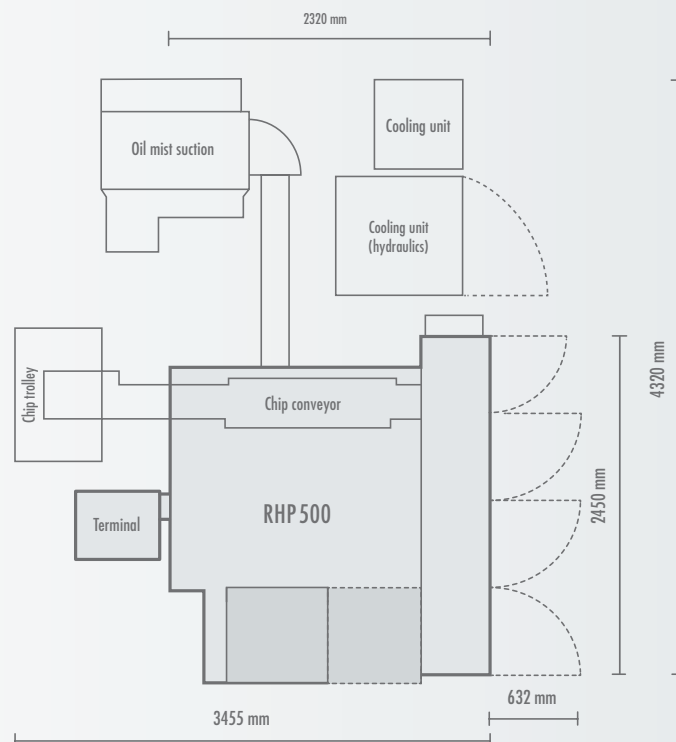

Röders RHP 500L

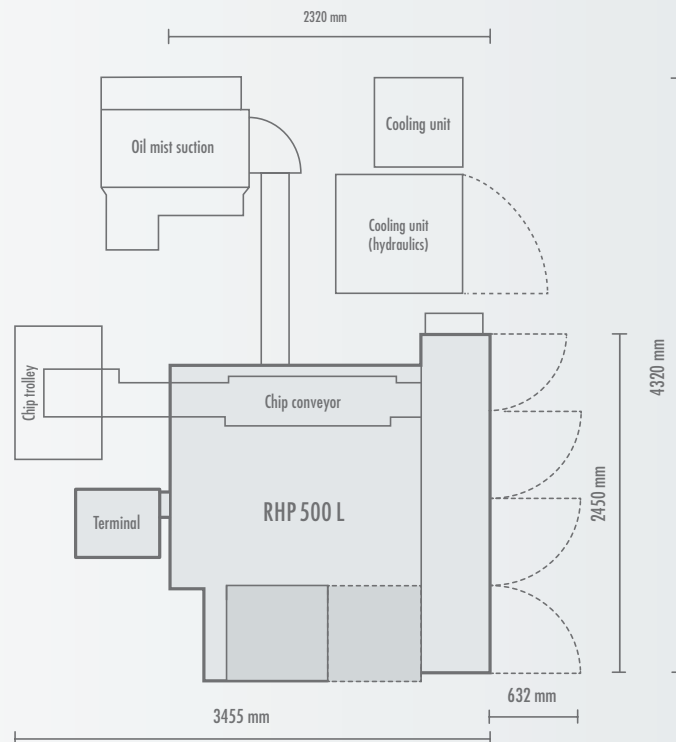

Image similar

- > Low version of RHP500 for relatively low work pieces
- > Low bridge and short Z-axis reduce deviations due to very short leverage between cutter and guideways
- > Highest precision and surface quality in 3-axis machining

Technical data

Machining range	500 mm x 552 mm x 150 mm
Table size	600 mm x 540 mm
Maximum height	455 mm between spindle nose and machine table
Workpiece weight	Maximum 400 kg
Feed	0 – 60,000 mm/min
Milling spindle (standard)	42,000 rpm, 14 kW, HSK E40, maximum tool diameter 16 mm (others on request)
Tool changer	42 places (chain changer – can be loaded during machining) integrated measuring laser
Chip disposal	With 2 screws into chip box behind the machine, additional chip conveyor optional
Machine weight	~10.0 t
Required space	W 3015 mm x L 2510 mm x H 2750 mm





>> Röders worldwide

Highly efficient service and short reaction times are guaranteed by Röders through well-trained local technicians. In the USA, China, France and Vietnam Röders is represented by its own subsidiaries.

In many other countries, Röders maintains longstanding partnerships with renowned companies for local service.

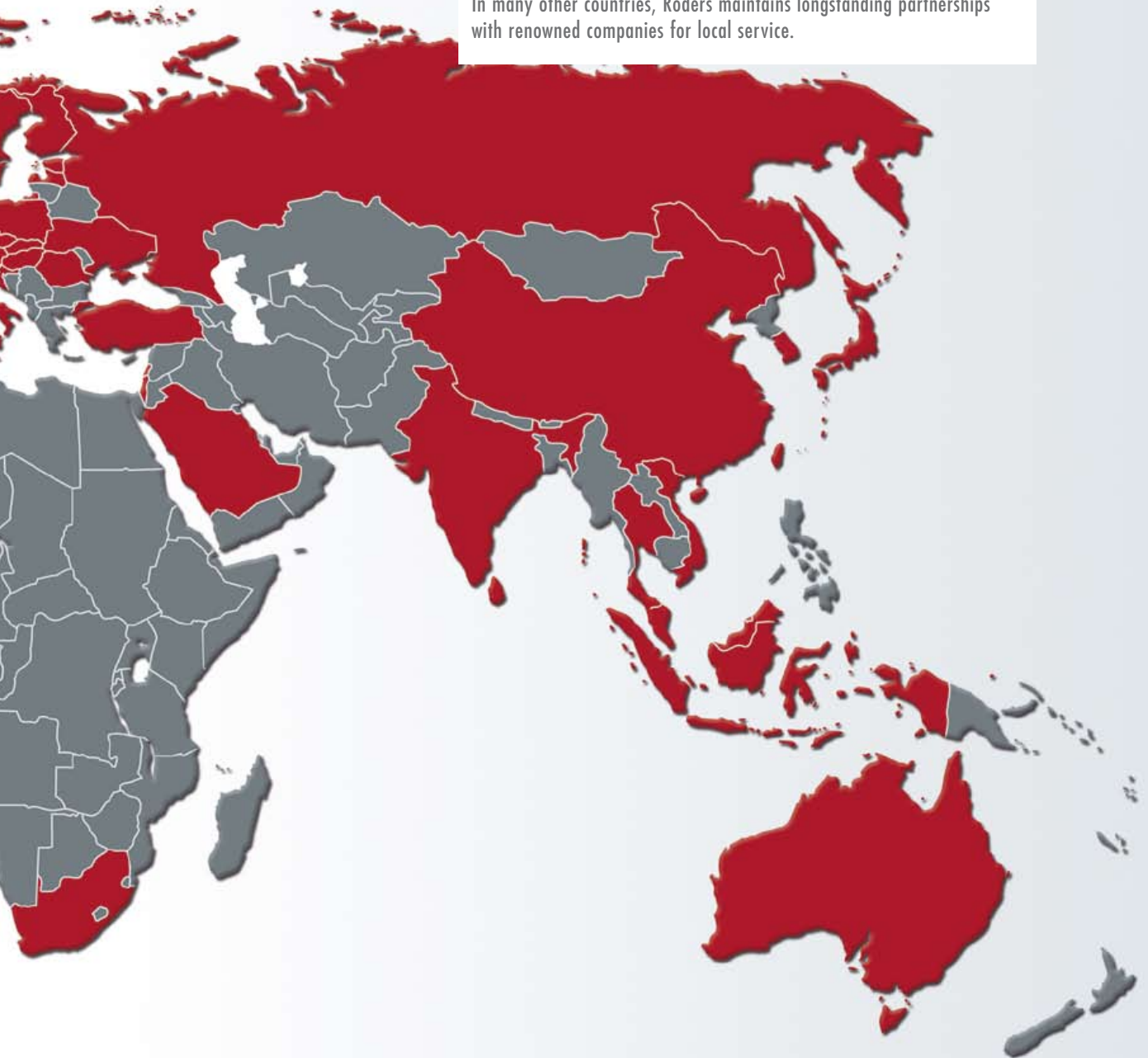

>> Machines for Milling and Grinding >> Blow Moulds for PET Bottles
>> Röders Pewter & Röders ART



Röders GmbH
Scheibenstr. 6 / 29614 Soltau / Germany
Tel. +49 5191-603-43, Fax +49 5191-603-38
E-Mail hsc@roeders.de / www.roeders.de

HIGH TECH IS OUR BUSINESS.

röders
TEC